

RELEASE STATUS
Production

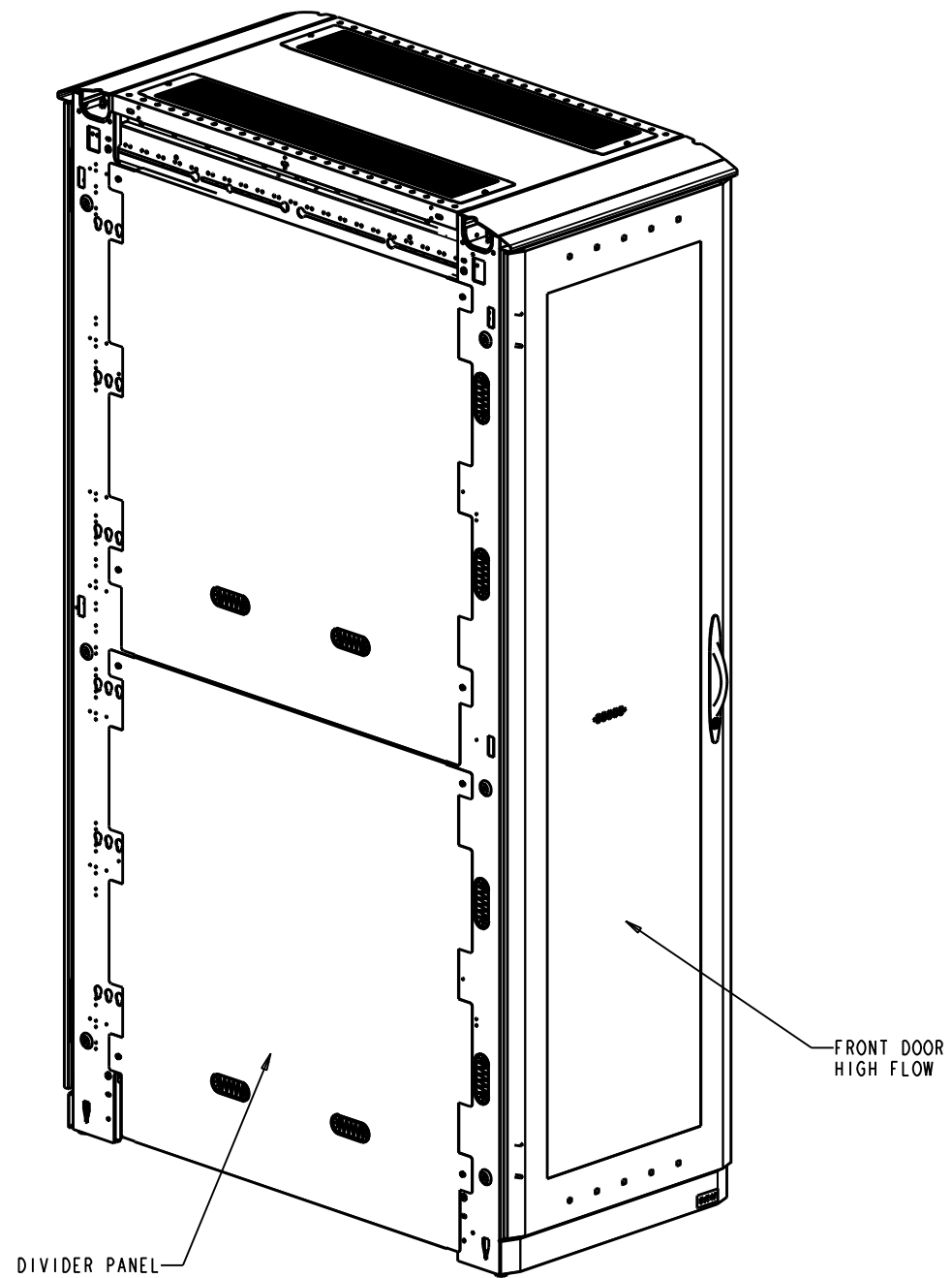

FRONT ISO

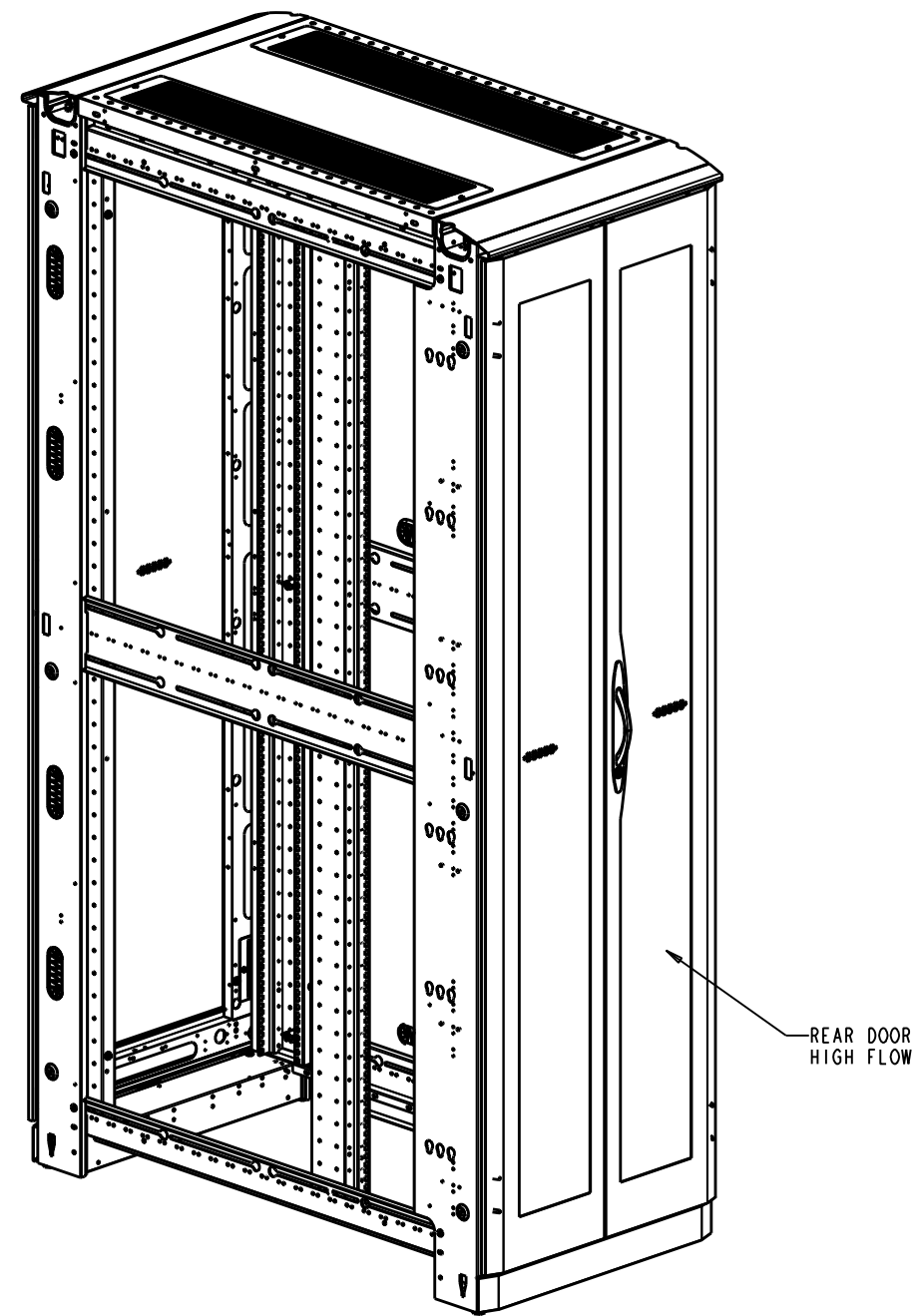

REAR ISO

SHIPPING WEIGHT: 380 LBS

REV	REV. DATE	REV'D BY	PRODUCTION RELEASE	ECN OR EPR NUMBER
-	-	-	PRODUCTION RELEASE	EPR113222
-	-	-	CURRENT REVISION DESCRIPTION	-

THIS DRAWING CONTAINS PROPRIETARY INFORMATION AND IS LOANED SUBJECT TO RETURN UPON DEMAND AND UPON THE EXPRESS CONDITION THAT IT WILL NOT BE USED IN ANY WAY DETRIMENTAL TO THE INTEREST OF EATON CORPORATION

DRAWN IN THIRD ANGLE PROJECTION

TOLERANCE UNLESS SPEC'D
 .XX ± .02
 .XXX ± .005
 < ± .1
 ALL DIMENSIONS IN INCHES

CAGE NUMBER: 81824	CUSTOMER: EATON CHANNEL
DESIGN MGMT SITE: Worcester	DES. BY DNeIson 08/16/11
MATERIAL:	DRWN. BY DNeIson 08/16/11
MATERIAL FINISH:	PROD. GRP 50 - Paramount
SPEC #:	COLOR: -
	CRS GA: N/A
	OTHER: -

EATON	
CONFIG - 44U X 24W X 48D PARAMOUNT W/ RACK HYGIENE	
SHEET: 1 OF 8	REV DATE: -
D PMT442448H	REV -

RELEASE STATUS
Production

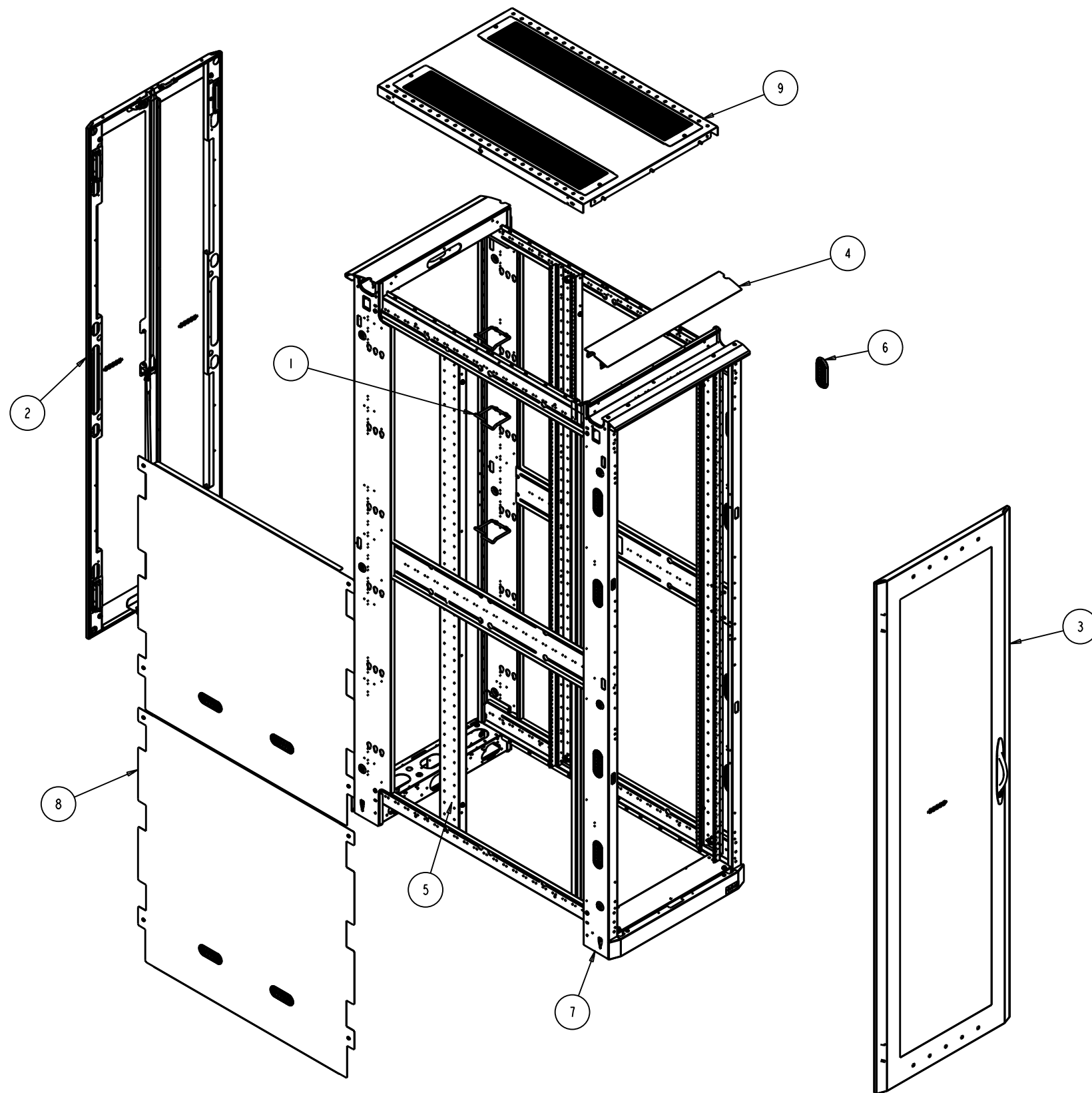

ASSEMBLY WIRING NOTE:

- 1. GROUND ALL DOORS, RAILS, TOP AND DIVIDER PANELS.
USE GROUNDING LANYARDS FROM KIT P/N GRNDPMT.
USE STANDARD W/L GROUND POINTS FOR ATTACHMENT AREAS.

ITEM	TYPE	DOCUMENT #	REV	DESCRIPTION	QTY
10	SA	GRNDPMT	-	GROUND KIT - PARAMOUNT	1
9	MA	PMTNWP2448	-	ASSEMBLY - TOP PANEL, 24W X 48D	1
8	MA	PMTJVD4448S	-	DIVIDER PANEL ASY - 44U X 48D	1
7	MA	PMTFRM442445	-	WLD - FRAME, 44U X 24W X 45D	1
6	MA	JWOVLGROM	A	GROMMET - OVAL 1.5WX4L	8
5	MA	JRM10000_	-	RACK MOUNT RAILS - 44U	1
4	MA	JFTK24_	B	FRAME TRIM KIT - 24"W	1
3	MA	JDDHF8424L	-	DOOR, HIGH FLOW	1
2	MA	JDDHF8424	-	ASSEMBLY - SPLIT DOOR, HIGH FLOW	1
1	MA	CMDRNR032U_	-	D-RING KIT, 2U	1

THIS DRAWING CONTAINS PROPRIETARY INFORMATION AND IS LOANED SUBJECT TO RETURN UPON DEMAND AND UPON THE EXPRESS CONDITION THAT IT WILL NOT BE USED IN ANY WAY DETRIMENTAL TO THE INTEREST OF EATON CORPORATION

DRAWN IN THIRD ANGLE PROJECTION

TOLERANCE UNLESS SPEC'D
 .XX ± .02
 .XXX ± .005
 < ± .1"

ALL DIMENSIONS IN INCHES

CAGE NUMBER: 81824
 CUSTOMER: EATON CHANNEL
 DES. BY: DNeison 08/16/11
 DRWN. BY: DNeison 08/16/11
 DESIGN MGMT SITE: Worcester
 PROD. GRP: 50 - Paramount
 COLOR: -
 CRS GA: N/A
 OTHER: -
 MATERIAL: -
 MATERIAL FINISH: -
 SPEC #: -



CONFIG - 44U X 24W X 48D
PARAMOUNT W/ RACK HYGIENE

SHEET: 2 OF 8
 REV DATE: -
 D PMT442448H REV -

REV	REV. DATE	REV'D BY	PRODUCTION RELEASE	ECN OR EPR NUMBER
-	-	-	PRODUCTION RELEASE	EPR113222
-	-	-	CURRENT REVISION DESCRIPTION	-

RELEASE STATUS
Production



TOP

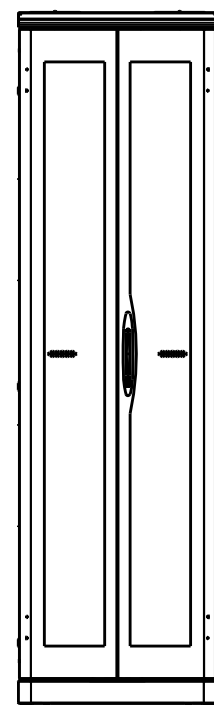
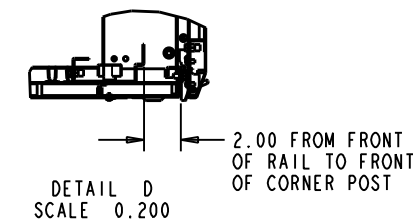
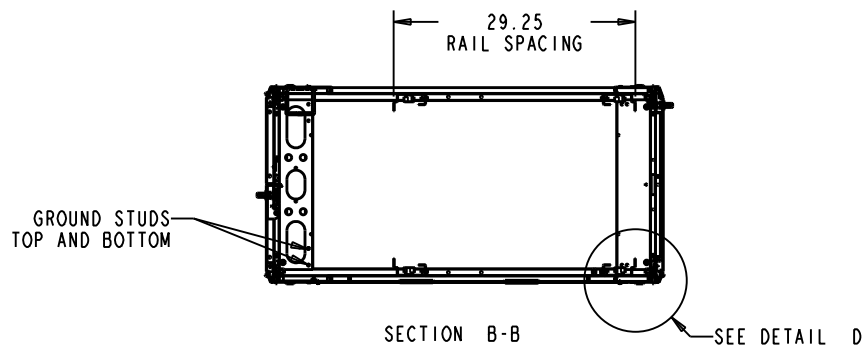

REAR

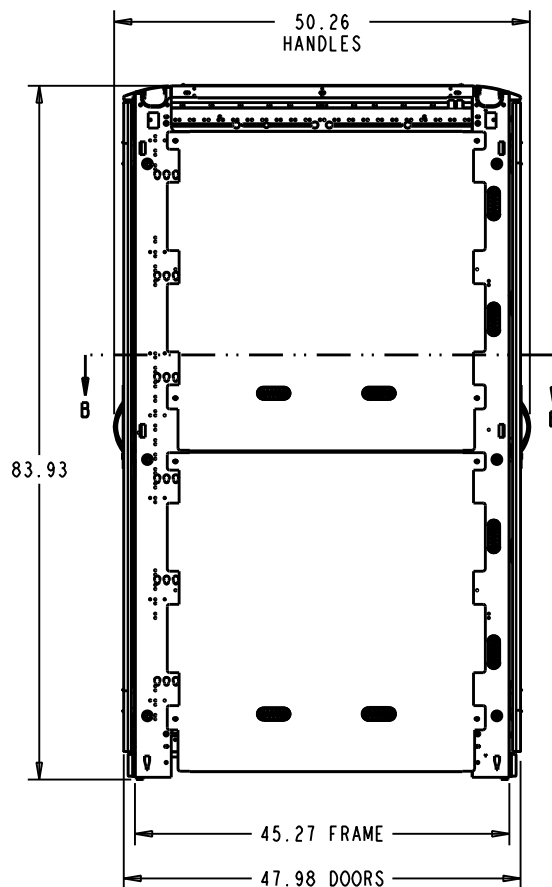

LEFT SIDE

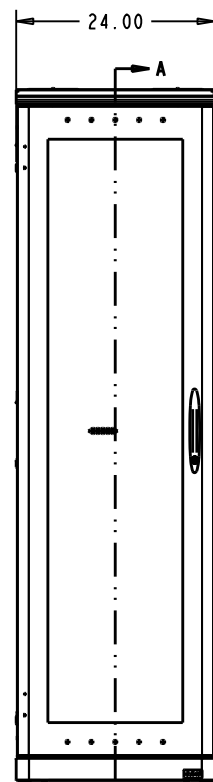

FRONT

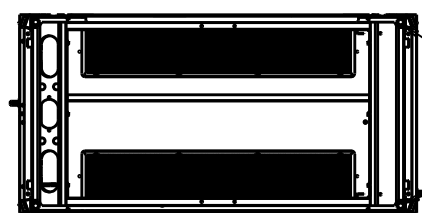
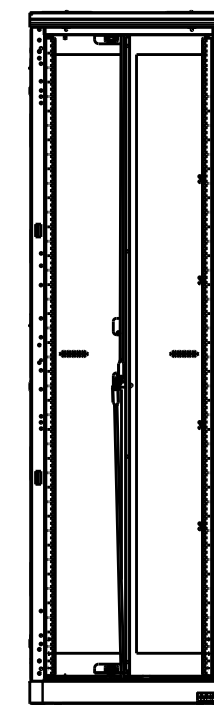
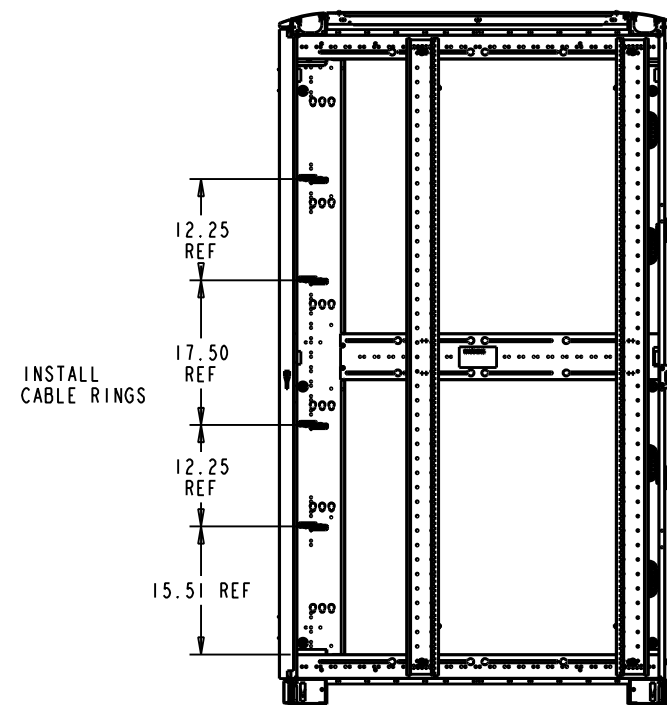

BOTTOM

LEVELING FEET

<small>THIS DRAWING CONTAINS PROPRIETARY INFORMATION AND IS LOANED SUBJECT TO RETURN UPON DEMAND AND UPON THE EXPRESS CONDITION THAT IT WILL NOT BE USED IN ANY WAY DETRIMENTAL TO THE INTEREST OF EATON CORPORATION</small>	CAGE NUMBER:	CUSTOMER: EATON CHANNEL	
	81824	DES. BY D Nelson 08/16/11	
	DESIGN MGMT SITE:	DRWN. BY D Nelson 08/16/11	
	Worcester	PROD. GRP 50 - Paramount	
<small>DRAWN IN THIRD ANGLE PROJECTION</small> 	MATERIAL:	COLOR: -	CONFIG - 44U X 24W X 48D PARAMOUNT W/ RACK HYGIENE
<small>TOLERANCE UNLESS SPEC'D .XX ± .02 .XXX ± .005 < ± 1"</small>	MATERIAL FINISH:	CRS GA: N/A	
<small>ALL DIMENSIONS IN INCHES</small>	SPEC #:	OTHER: -	SHEET: 3 OF 8 REV DATE: -
REV REV. DATE REV'D BY PRODUCTION RELEASE CURRENT REVISION DESCRIPTION	EPR113222 ECN OR EPR NUMBER	D PMT442448H REV -	

-	-	-	PRODUCTION RELEASE	EPR113222
REV	REV. DATE	REV'D BY	CURRENT REVISION DESCRIPTION	ECN OR EPR NUMBER