

RELEASE STATUS
Production

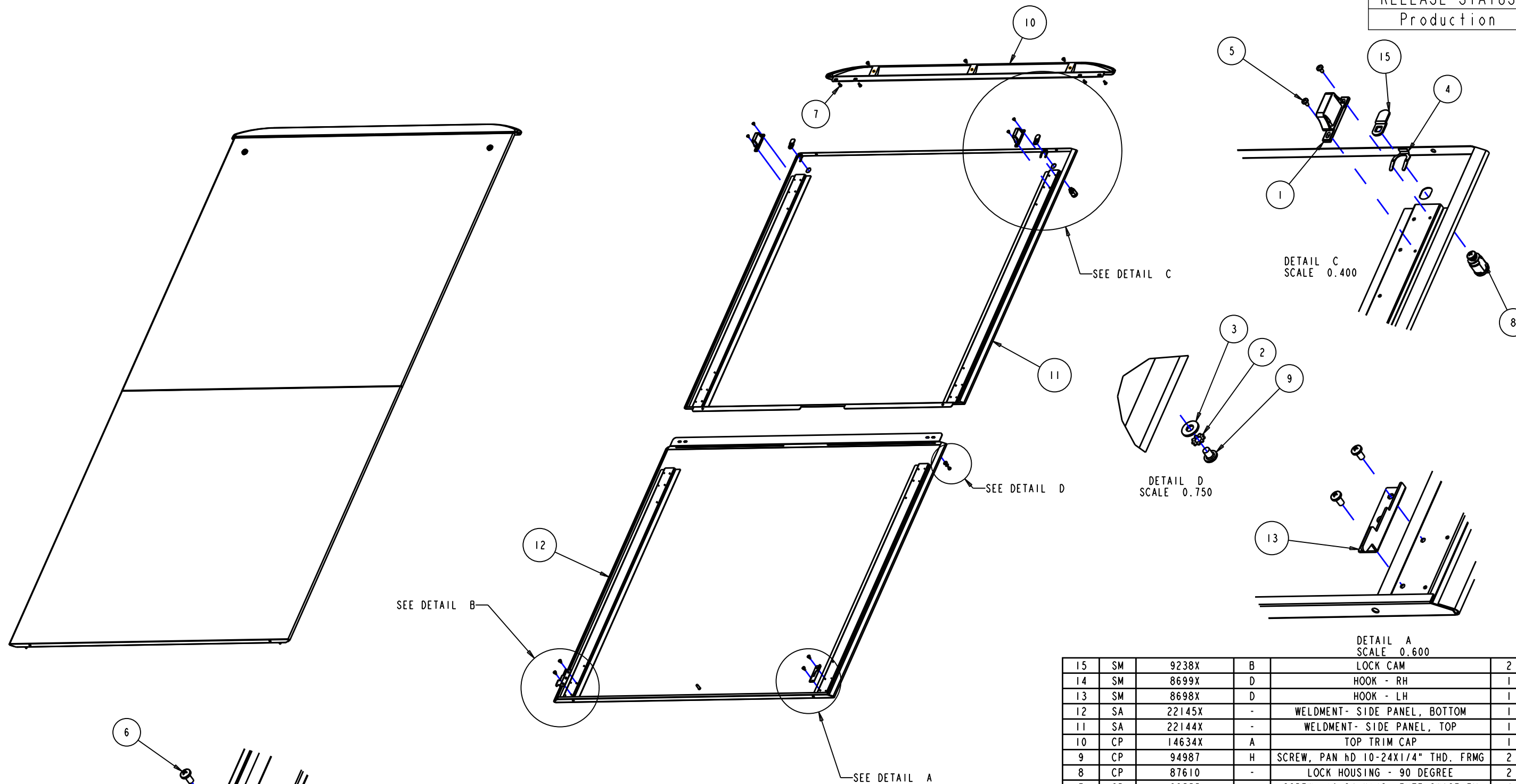

ITEM	TYPE	DOCUMENT #	REV	DESCRIPTION	QTY
15	SM	9238X	B	LOCK CAM	2
14	SM	8699X	D	HOOK - RH	1
13	SM	8698X	D	HOOK - LH	1
12	SA	22145X	-	WELDMENT- SIDE PANEL, BOTTOM	1
11	SA	22144X	-	WELDMENT- SIDE PANEL, TOP	1
10	CP	14634X	A	TOP TRIM CAP	1
9	CP	94987	H	SCREW, PAN HD 10-24X1/4" THD. FRMG	2
8	CP	87610	-	LOCK HOUSING - 90 DEGREE	2
7	CP	82555	-	SCREW, 10-24 X1/2 FHTF SWAGE FM	4
6	CP	66714	H	SCREW, PAN HEAD SWAGEFORM	7
5	CP	66249	-	SCREW, 8AB X 3/8	4
4	CP	60297	B	#3 SPRING CLIP LOCK	2
3	CP	54225	E	WASHER - #10, FLAT	2
2	CP	18977	-	WASHER	2
1	CA	87316	-	GRABBER LATCH	2

DETAIL B
SCALE 0.600

REV	REV. DATE	REV'D BY	CURRENT REVISION DESCRIPTION	ECN OR EPR NUMBER
-	04/16/12	MTroio	PRODCUTIOON RELEASE	EPR113430

THIS DRAWING CONTAINS PROPRIETARY INFORMATION AND IS LOANED SUBJECT TO RETURN UPON DEMAND AND UPON THE EXPRESS CONDITION THAT IT WILL NOT BE USED IN ANY WAY DETRIMENTAL TO THE INTEREST OF EATON CORPORATION

DRAWN IN THIRD ANGLE PROJECTION

TOLERANCE UNLESS SPEC'D
XX ± .02
.XXX ± .005
< ± .1"

ALL DIMENSIONS IN INCHES

CAGE NUMBER: 81824

ORIG EPR: EPR12-3459

DES. BY: MTroio 04/16/12

DRWN. BY: MTroio 04/16/12

DESIGN MGMT SITE: Worcester

PROD. GRP: Multiple Association

COLOR: -

MATERIAL: CR5 GA: N/A

MATERIAL FINISH: OTHER: NOTED

SPEC #: Powder Coat - Variable

EATON

SIDE PANEL, SPLIT
PARAMOUNT 91H" X 45" D

SHEET: 1 OF 1

REV DATE: 04/16/12

D JSPS9145 REV -