

RELEASE STATUS  
Production

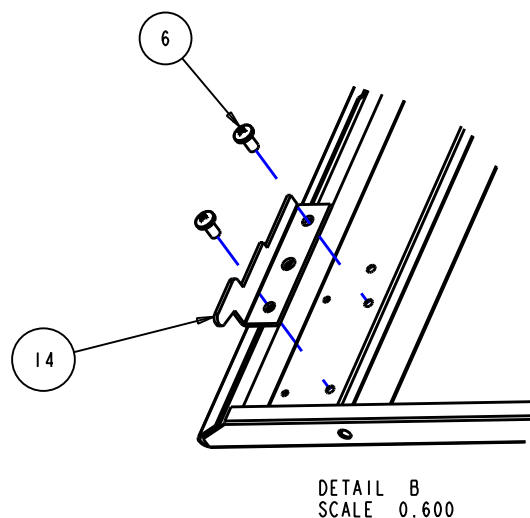
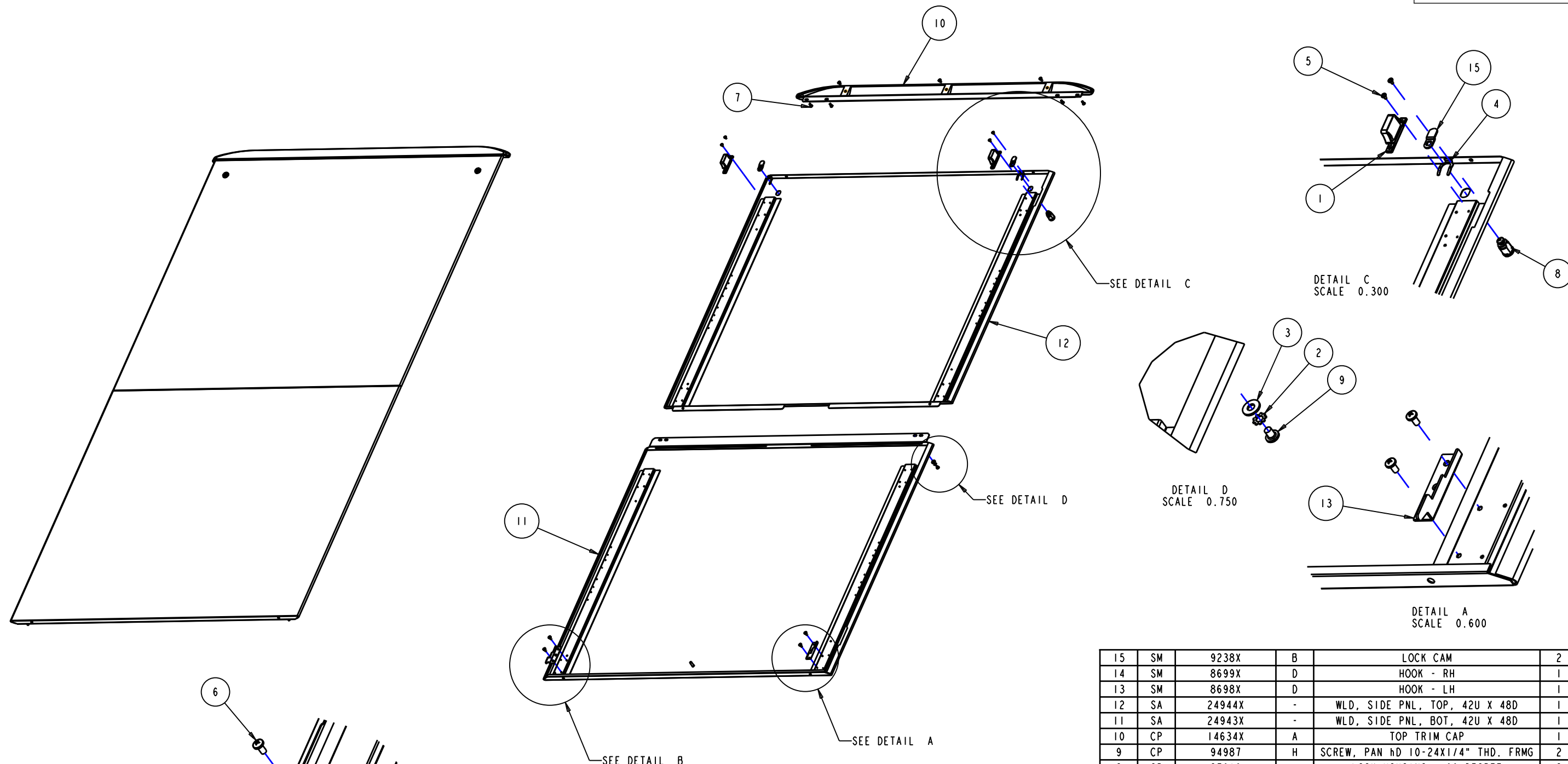

SHIPPING WEIGHT: 52 LBS

15	SM	9238X	B	LOCK CAM	2
14	SM	8699X	D	HOOK - RH	1
13	SM	8698X	D	HOOK - LH	1
12	SA	24944X	-	WLD, SIDE PNL, TOP, 42U X 48D	1
11	SA	24943X	-	WLD, SIDE PNL, BOT, 42U X 48D	1
10	CP	14634X	A	TOP TRIM CAP	1
9	CP	94987	H	SCREW, PAN hD 10-24X1/4" THD. FRMG	2
8	CP	87610	-	LOCK HOUSING - 90 DEGREE	2
7	CP	82555	-	SCREW, 10-24 X1/2 FHTF SWAGE FM	4
6	CP	66714	H	SCREW, PAN HEAD SWAGEFORM	7
5	CP	66249	-	SCREW, 8AB X 3/8	4
4	CP	60297	B	#3 SPRING CLIP LOCK	2
3	CP	54225	E	WASHER - #10, FLAT	2
2	CP	18977	-	WASHER	2
1	CA	87316	-	GRABBER LATCH	2
ITEM	TYPE	DOCUMENT #	REV	DESCRIPTION	QTY

THIS DRAWING CONTAINS PROPRIETARY INFORMATION AND IS LOANED SUBJECT TO RETURN UPON DEMAND AND UPON THE EXPRESS CONDITION THAT IT WILL NOT BE USED IN ANY WAY DETRIMENTAL TO THE INTEREST OF EATON CORPORATION	CAGE NUMBER:	81824	CUSTOMER:	WRIGHTLINE
	DESIGN MGMT SITE:	Worcester	DES. BY:	MTroio 03/16/12
	DRAWN IN THIRD ANGLE PROJECTION	<input type="checkbox"/>	DRWN. BY:	MTroio 03/16/12
	TOLERANCE UNLESS SPEC'D	.XX ± .02 .XXX ± .005 < ± .1"	PROD. GRP:	Multiple Association
ALL DIMENSIONS IN INCHES	<input type="checkbox"/>	MATERIAL:	CRS GA: N/A	
		MATERIAL FINISH:	OTHER: NOTED	
		SPEC #	Powder Coat - Variable	



SIDE PNL, SPLIT, 42U X 48D  
PARAMOUNT 81H" X 45" D  
SHEET: 1 OF 1  
REV DATE: 03/16/12  
D JSPS8145 REV -

REV	REV. DATE	REV'D BY	CURRENT REVISION DESCRIPTION	ECN OR EPR NUMBER
-	03/16/12	MTroio	PRODUCTION RELEASE	EPR123513