

Installing the Vertical Blanking Panels

Complete these instructions to install vertical blanking panels. Vertical blanking panels are designed to be used between or beside existing data center enclosures.

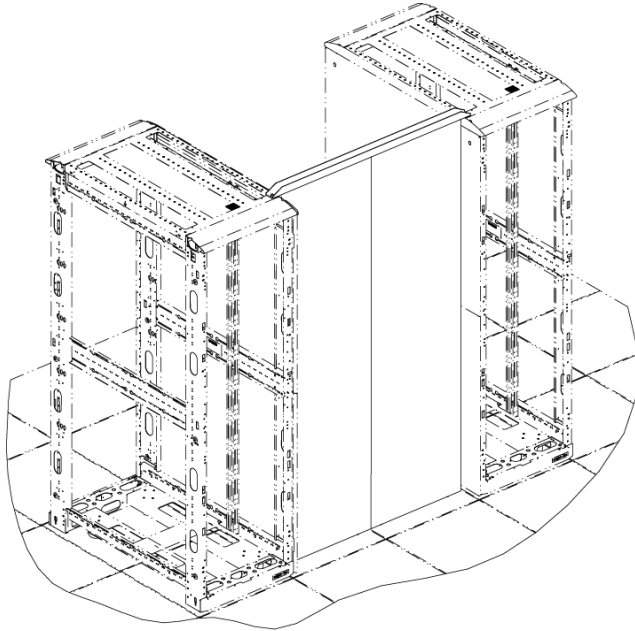

Applications

Make sure you have the appropriate size vertical blanking panel for your application:

Item Number	Description	Size
17160080	Vertical Blanking Panel	80" H x 13.5" W
17160081	Vertical Blanking Panel	84" H x 23.5" W
17160082	Vertical Blanking Panel	84" H x 46.25" W
17160083	Vertical Blanking Panel	84" H x 49" W

Prerequisites

- Clear any equipment or cabling that might interfere with the vertical blanking panel.
- Unpack all components of the vertical blanking panels.
- Common installation tools including a utility knife, and a #2 Philips screwdriver.
- Powered driver with 3/8", 1/2", and 9/16" hex sockets and extensions.
- Drill with bits suitable for metal, wood, and cement flooring if needed.

Assemble the Vertical Blanking Panel

Complete the following steps to assemble the vertical blanking panel.

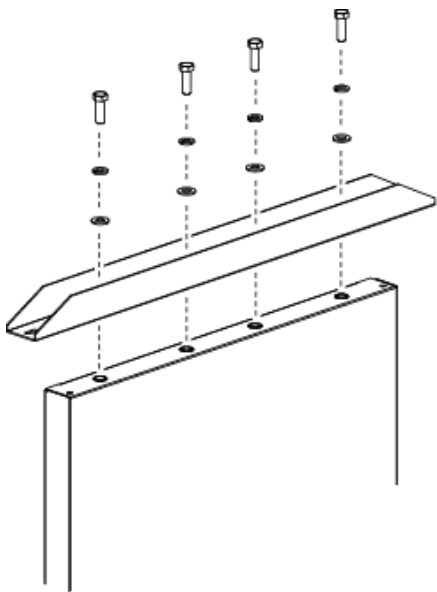

1. Align the top bracket with the top of the blanking panel or panels.
2. Insert one set of screw, lock washer, and flat washer per threaded hole in the top of the panel and tighten.

Most installations use four sets of fasteners per panel.

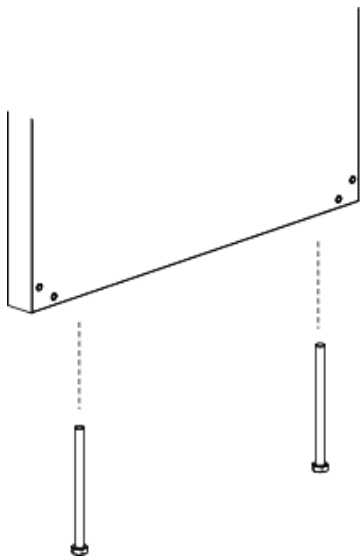

3. Insert two leveling screws into the bottom of each panel.

Install the Vertical Blanking Panel

Complete the following steps to install vertical blanking panels.

1. Mock up the panel assembly between the enclosures where it will be installed.

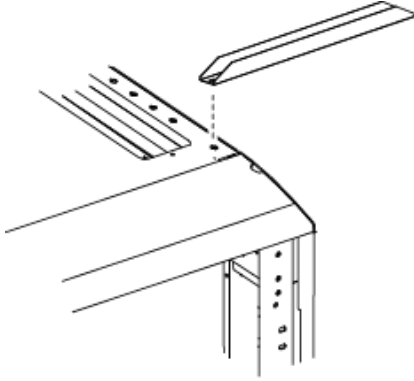

Make sure the bracket is aligned with a flat and level surface on the top of the enclosure. If possible, mount the bracket where it will not interfere with the removable top panel or cable routing.

2. If existing open holes align with the mounting holes in the top bracket, continue to step 3.
 - a. If there are no open holes for mounting the top bracket, mark any holes that must be drilled to accommodate the top bracket.
 - b. Remove the panel assembly and drill holes as needed.
 - c. Align the panel assembly with the mounting holes.

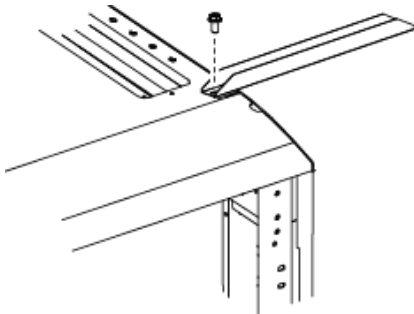

3. Insert one screw per bracket mounting hole into the corresponding hole in the top of the enclosure and tighten.

4. Level and align the installed panels.

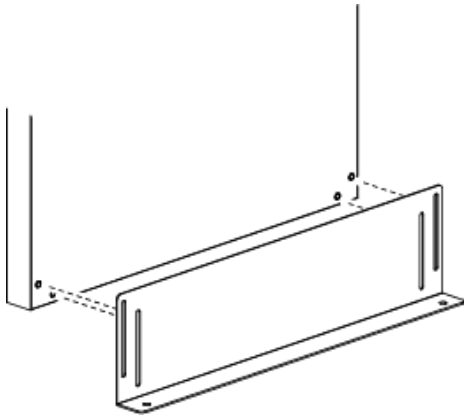

5. Mock up the bottom bracket. Mark the location of all required floor anchor screw mounting holes.

Note: Anchor screws are not provided. Use the appropriate type of anchor screw for the flooring in the data center.

6. Drill holes as needed in the floor.

7. Align the bottom bracket with the holes in the panel and floor.

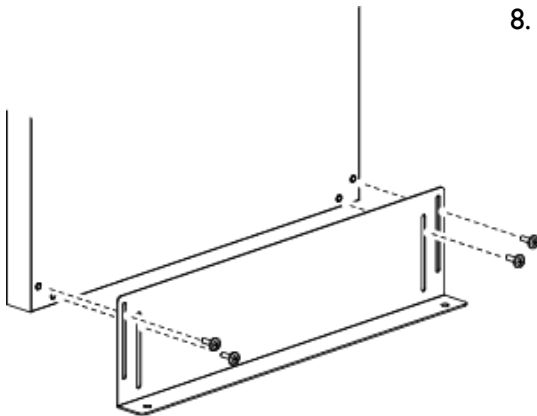

8. Insert four screws through the bottom bracket into the panel. Do not tighten until the anchor screws are installed.

9. Insert two anchor screws through the bottom bracket into the floor.

Note: Anchor screws are not provided. Use the appropriate type of anchor screw for the flooring in the data center.

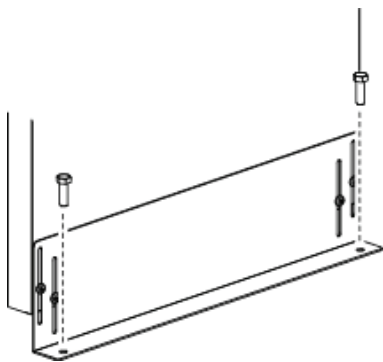

10. Tighten all screws.

Installation is complete.