

RELEASE STATUS
Production

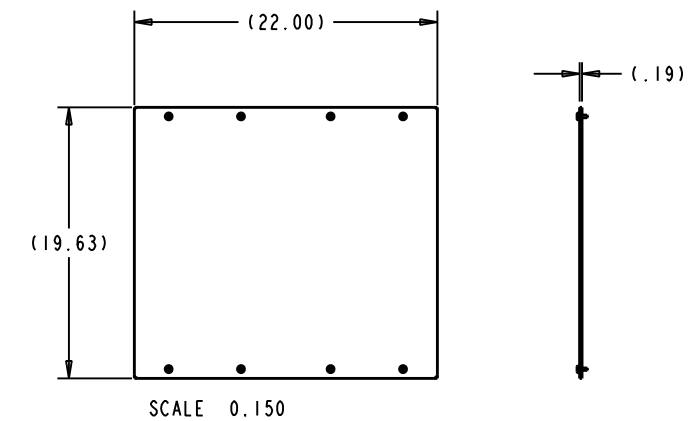

1 PLACE IN BAG FOR SHIPMENT

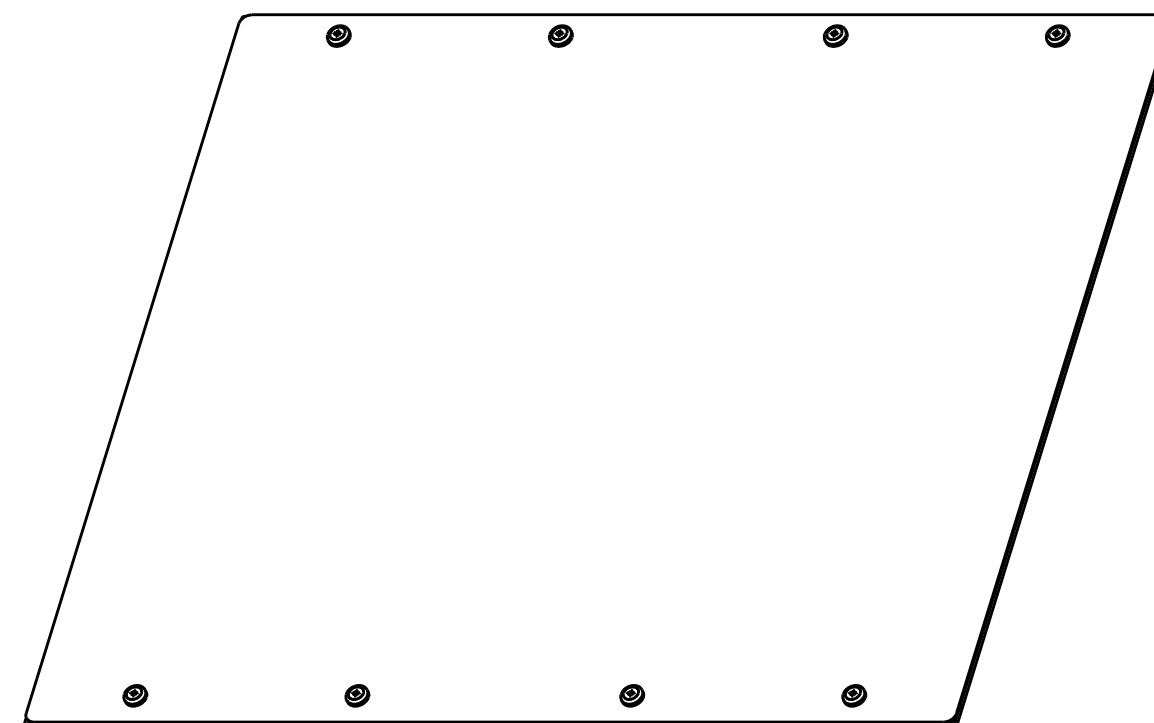
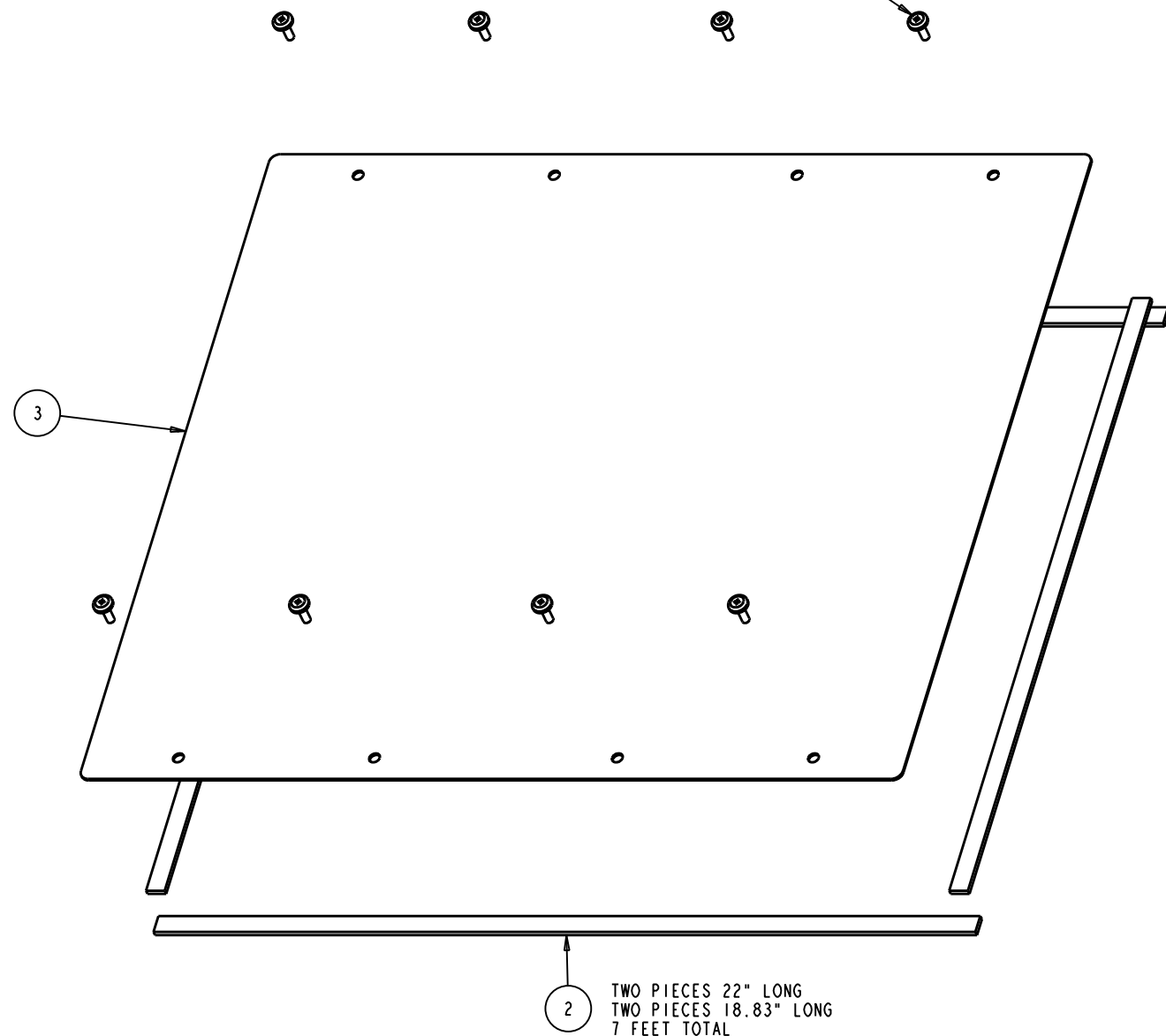

SHIPPING WEIGHT: 8 POUNDS

3	SM	28596X	BLANKING PANEL, 22 X 19.63	1
2	CP	94183	GASKET, 0.5 X 0.12 THK, ACRYLIC ADH	4
1	CP	87442	10-32 PHILIPS SCREW	8
ITEM	TYPE	DOCUMENT #	DESCRIPTION	QTY

THIS DRAWING CONTAINS PROPRIETARY INFORMATION AND IS LOANED SUBJECT TO RETURN UPON DEMAND AND UPON THE EXPRESS CONDITION THAT IT WILL NOT BE USED IN ANY WAY DETRIMENTAL TO THE INTEREST OF EATON CORPORATION

CAGE NUMBER:	81824	ORIG EPR:	EPR133904
DES. BY:	MQuaglia	03/26/13	
DRWN. BY:	MQuaglia	04/09/13	
DESIGN MGMT SITE:	Worcester	PROD. GRP:	-
		COLOR:	-
		CRS GA:	-
		OTHER:	-
MATERIAL:			
MATERIAL FINISH:			
SPEC #:			



BLANKING PANEL, 22 X 19.63
TEL CHIMNEY

SHEET: 1 OF 2 REV DATE: 04/10/13

-	04/10/13	MQuaglia	ENGINEERING RELEASE	-
REV	REV. DATE	REV'D BY	CURRENT REVISION DESCRIPTION	ECN OR EPR NUMBER

DRAWN IN THIRD ANGLE PROJECTION

TOLERANCE UNLESS SPEC'D
.XX ± .02
.XXX ± .005
< ± 1°
ALL DIMENSIONS IN INCHES

D	JTPTCFP	REV	-
---	---------	-----	---

wright•line

DESCRIPTION		ASSEMBLY NUMBER	REVISION
BLANKING PANEL, 22 X 19.63		JTPTCFP	-
TEL CHIMNEY			04/10/13

ITEM NO.	PART TYPE	NEW REL	PREV REL	REV'D REL	NO ACT	NUMBER	ASSY LVL	REV	DESCRIPTION1	DESCRIPTION2	QTY	PRODUCT GROUP	VENDOR	VENDOR P/N	NOTES	RELEASE STATUS	MAKE/BUY	NEW PART
1	MA					JTPTCFP	1	-	BLANKING PANEL, 22 X 19.63	TEL CHIMNEY	1	-				Production		
2	SM					28596X	2	1	BLANKING PANEL, 22 X 19.63	TEL CHIMNEY	1	16 - Air Flow Management				Prototype		
3	SM					28596X_GENERIC	3	1	BLANKING PANEL, 22 X 19.6,3	TEL CHIMNEY	1	16 - Air Flow Management				Prototype		
4	CP					94183	2	-	GASKET, 0.5 X 0.12 THK, ACRYLIC ADH	EXTRA SOFT, BLACK	4					Production	B	X
5	CP					87442	2	-	10-32 PHILIPS SCREW	W/PLASTIC WASHER	8					Production		