

RELEASE STATUS
Production

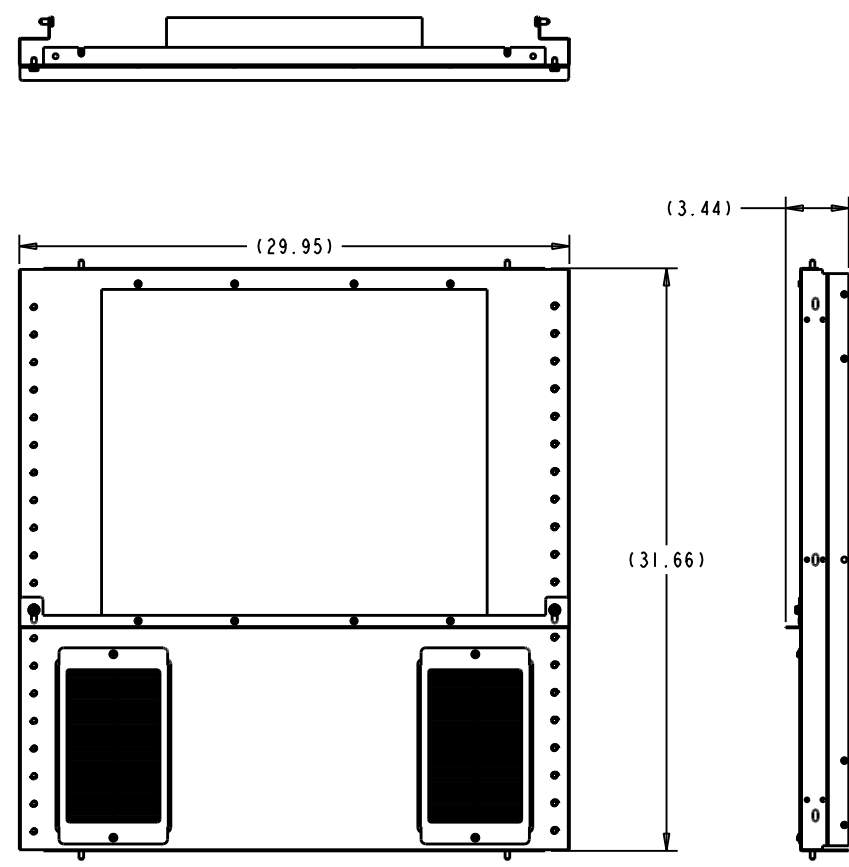
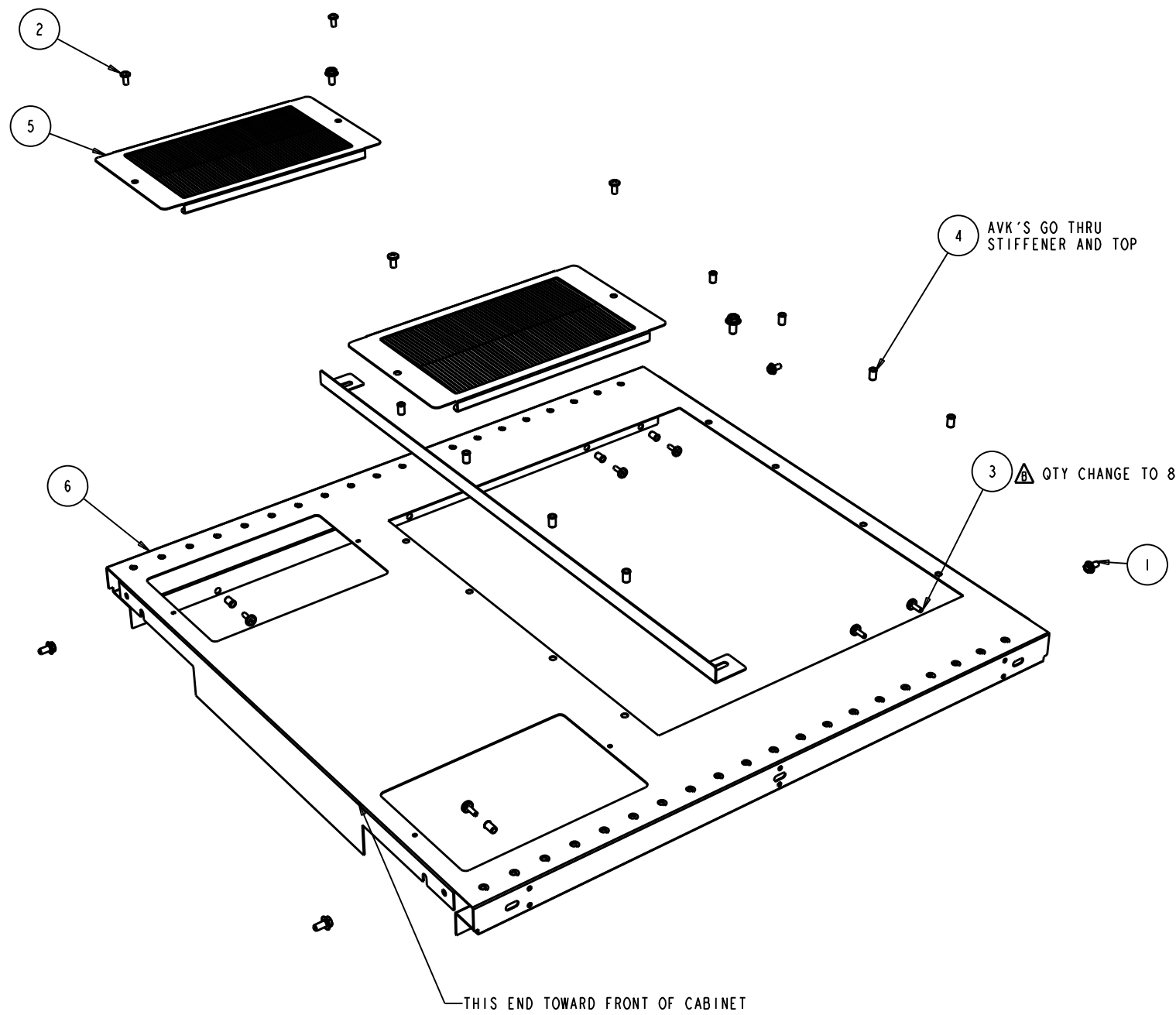

SHIPPING WEIGHT: 12 POUNDS

ITEM	TYPE	DOCUMENT #	DESCRIPTION	QTY
7	SM	28970X	STIFF, PMOUNT TOP, TEL CHIMNEY	1
6	SA	28626X	P-MOUNT TOP, TEL. CHIMNEY, 30W x 40D	1
5	MA	25403X	ASSY,BRUSH TOP PANEL, HCS LITE - 40"DP.	2
4	CP	89811	A-K SERIES REVNUT 10-32	16
3	CP	87442	10-32 PHILIPS SCREW	8
2	CP	66714	SCREW, PAN HEAD SWAGEFORM	4
1	CP	54348	SCREW, 1/4-20X1/2 HEX WSHR HD	6

REV	REV. DATE	REV'D BY	CURRENT REVISION DESCRIPTION	ECN OR EPR NUMBER
B	07/11/13	MQuaglia	CHANGE QUANTITY OF 87442 TO 8 (FROM 16)	N130198

THIS DRAWING CONTAINS PROPRIETARY INFORMATION AND IS LOANED SUBJECT TO RETURN UPON DEMAND AND UPON THE EXPRESS CONDITION THAT IT WILL NOT BE USED IN ANY WAY DETRIMENTAL TO THE INTEREST OF EATON CORPORATION

DRAWN IN THIRD ANGLE PROJECTION

TOLERANCE UNLESS SPEC'D
.XX ± .02
.XXX ± .005
< ± 1"

ALL DIMENSIONS IN INCHES

CAGE NUMBER: 81824

ORIG EPR: EPRI33904

DES. BY: MQuaglia 03/26/13

DRWN. BY: MQuaglia 03/26/13

DESIGN MGMT SITE: Worcester

MATERIAL:

MATERIAL FINISH:

SPEC #:

EATON

P-MOUNT TOP, TEL. CHIMNEY, 30W x 40D

SHEET: 1 OF 2

REV DATE: 07/11/13

D JTPTC3040 REV B

wright • line

DESCRIPTION

P-MOUNT TOP, TEL. CHIMNEY, 30W x 40D

ASSEMBLY NUMBER

JTPTC3040

REVISION

B
07/11/13

ITEM NO.	PART TYPE	NEW REL	PREV REL	REV'D REL	NO ACT	NUMBER	ASSY LVL	REV	DESCRIPTION1	DESCRIPTION2	QTY	PRODUCT GROUP	VENDOR	VENDOR P/N	NOTES	RELEASE STATUS	MAKE/BUY	NEW PART
1	MA					JTPTC3040	1	B	P-MOUNT TOP, TEL. CHIMNEY, 30W x 40D	-	1	-				Production		
2	SA					28626X	2	-	P-MOUNT TOP, TEL. CHIMNEY, 30W x 40D	-	1	50 - Paramount				Production		
3	SM					PHANTOM_28626X	3	-	PART HAS BEEN PHANTOMED DUE TO STRUCTURE CHANGE	COULD BE USED TO CREATE MULTI-PART SUB-ASSEMBLY	ES	50 - Paramount				Production		
4	CP					87482	3	-	WELD STUD	1/4-20 x .75" LONG	1					Production	B	
5	CP					54348	2	-	SCREW, 1/4-20X1/2 HEX WSHR HD		6					Production		
6	CP					89811	2	-	A-K SERIES REVNUT 10-32	10-32 UNF, OPEN ENDED	16	42 - Linx AVK	INDUSTRIAL PRODUCTS	42KS4-1031-130		Production	B	
7	CP					87442	2	-	10-32 PHILIPS SCREW	W/PLASTIC WASHER	8					Production		
8	SM					28970X	2	-	STIFF, PMOUNT TOP, TEL CHIMNEY	-	1	16 - Air Flow Management				Production		
9	SM					28970X	3	-	START SHEETMETAL PART	-	1	16 - Air Flow Management				Production		
10	MA					25403X	2	-	ASSY, BRUSH TOP PANEL, HCS LITE - 40"DP.	NETWORK PARAMOUNT	2	51 - Vantage VS2				Production		X
11	SM					25404X	3	-	PANEL, BRUSH TOP - 40"DP. HCS LITE PARAMT	FOR DBL. WD. RECT. TOP CUTOUT	1	50 - Paramount				Production	M	X
12	CR					99567	3	-	BRUSH STRIP - 3" WIDE, NYLON	8.31" LONG	2	Multiple Association	McMASTER-CARR			Production	M	X
13	CP					66714	2	H	SCREW, PAN HEAD SWAGEFORM	(OR EQUIVALENT)	4					Production	B	