

RELEASE STATUS
Production

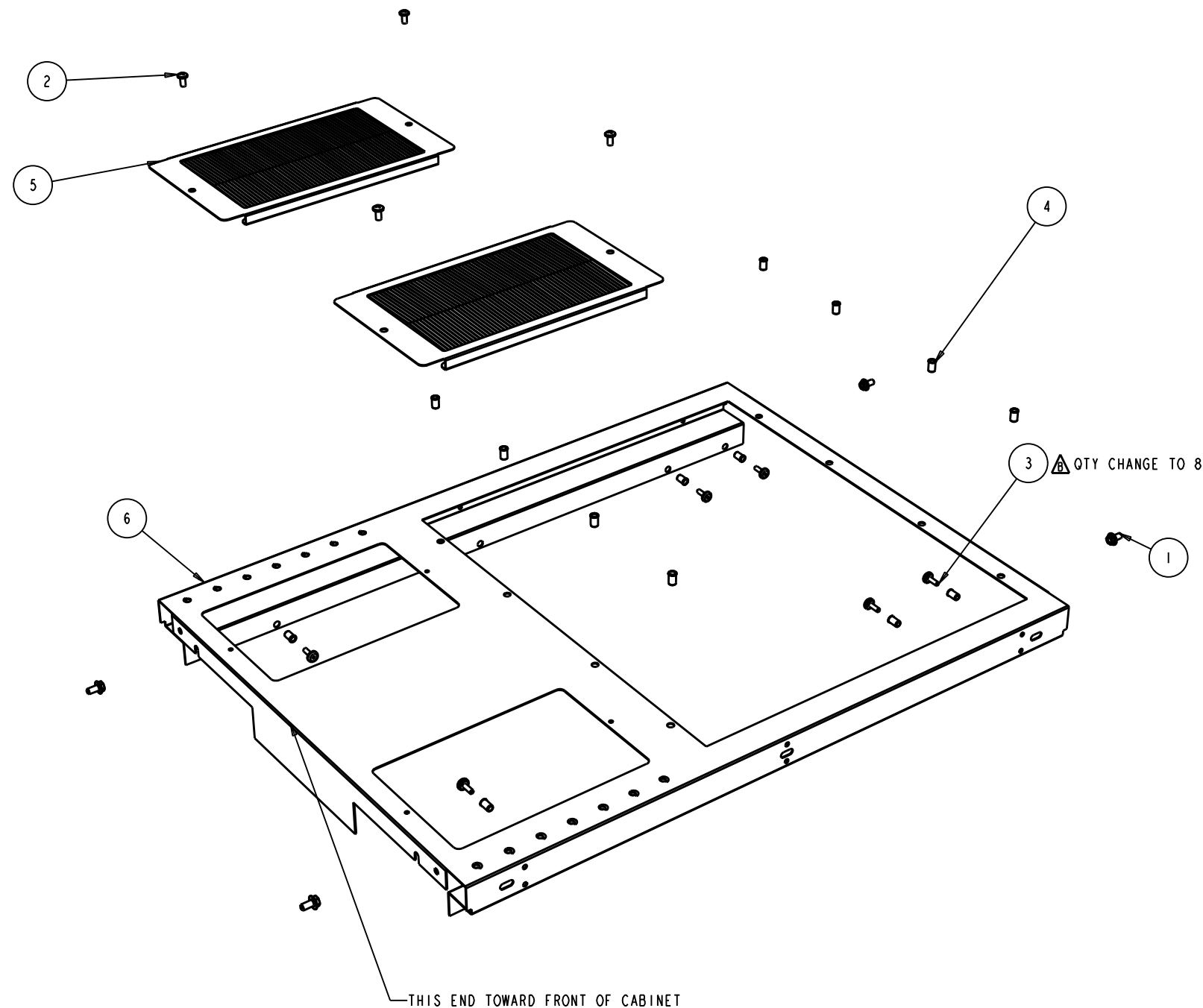

SHIPPING WEIGHT: 10 POUNDS

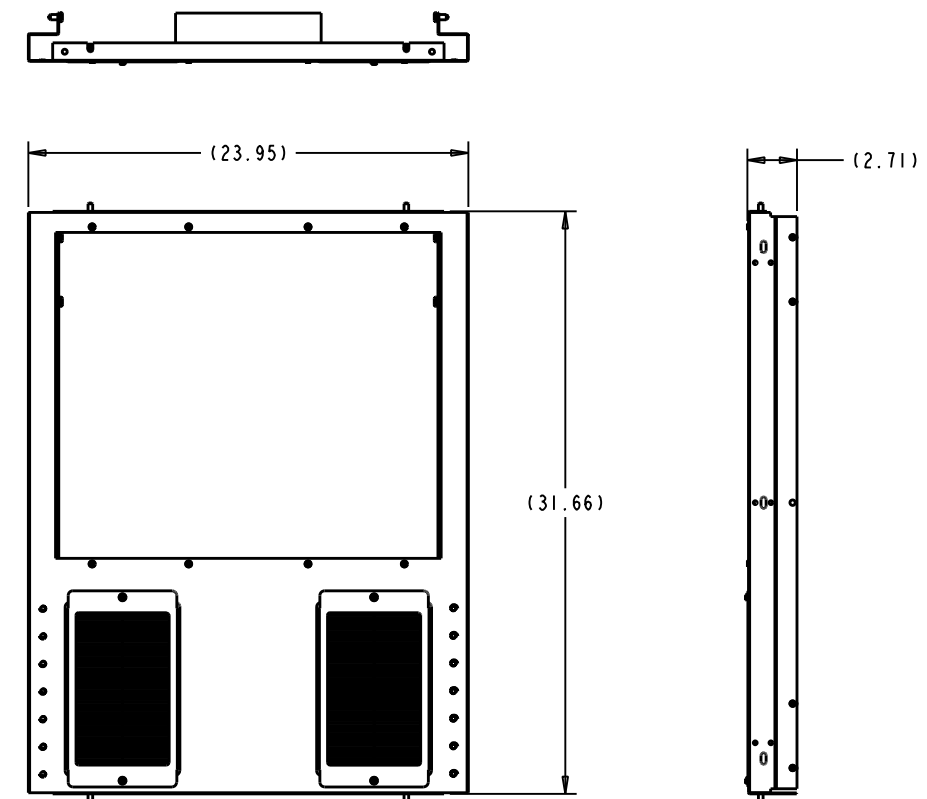

ITEM	TYPE	DOCUMENT #	DESCRIPTION	QTY
6	SA	28624X	P-MOUNT TOP, TEL. CHIMNEY, 24W x 40D	1
5	MA	25403X	ASSY,BRUSH TOP PANEL, HCS LITE - 40"DP.	2
4	CP	89811	A-K SERIES REVNUT 10-32	16
3	CP	87442	10-32 PHILIPS SCREW	8
2	CP	66714	SCREW, PAN HEAD SWAGEFORM	4
1	CP	54348	SCREW, 1/4-20X1/2 HEX WSHR HD	4

THIS DRAWING CONTAINS PROPRIETARY INFORMATION AND IS LOANED SUBJECT TO RETURN UPON DEMAND AND UPON THE EXPRESS CONDITION THAT IT WILL NOT BE USED IN ANY WAY DETRIMENTAL TO THE INTEREST OF EATON CORPORATION

DRAWN IN THIRD ANGLE PROJECTION

TOLERANCE UNLESS SPEC'D
.XX ± .02
.XXX ± .005
∠ ± 1°
ALL DIMENSIONS IN INCHES

CAGE NUMBER: 81824
ORIG EPR: EPRI33904
DES. BY: MQuaglia 03/26/13
DRWN. BY: MQuaglia 03/26/13
DESIGN MGMT SITE: Worcester
MATERIAL:
MATERIAL FINISH:
SPEC #:

EATON
P-MOUNT TOP, TEL. CHIMNEY, 24W x 40D
SHEET: 1 OF 2
REV DATE: 07/11/13
D JTPTC2440 REV B

REV	REV. DATE	REV'D BY	CURRENT REVISION DESCRIPTION	ECN OR EPR NUMBER
B	07/11/13	MQuaglia	CHANGE QUANTITY OF 87442 TO 8 (FROM 16)	N130198

wright • line

DESCRIPTION

P-MOUNT TOP, TEL. CHIMNEY, 24W x 40D

ASSEMBLY NUMBER

JTPTC2440

REVISION

B
07/11/13

ITEM NO.	PART TYPE	NEW REL	PREV REL	REV'D REL	NO ACT	NUMBER	ASSY LVL	REV	DESCRIPTION1	DESCRIPTION2	QTY	PRODUCT GROUP	VENDOR	VENDOR P/N	NOTES	RELEASE STATUS	MAKE/BUY	NEW PART
1	MA					JTPTC2440	1	B	P-MOUNT TOP, TEL. CHIMNEY, 24W x 40D	-	1	-				Production		
2	SA					28624X	2	-	P-MOUNT TOP, TEL. CHIMNEY, 24W x 40D	-	1	50 - Paramount				Production		
3	SM					PHANTOM_28624X	3	-	PART HAS BEEN PHANTOMED DUE TO STRUCTURE CHANGE	COULD BE USED TO CREATE MULTI-PART SUB-ASSEMBLY	1	ES 50 - Paramount				Production		
4	CP					87482	3	-	WELD STUD	1/4-20 x .75" LONG	1					Production	B	
5	CP					54348	2	-	SCREW, 1/4-20X1/2 HEX WSHR HD		4					Production		
6	CP					89811	2	-	A-K SERIES REVNUT 10-32	10-32 UNF, OPEN ENDED	16	42 - Linx AVK	INDUSTRIAL PRODUCTS	4784-S4-1031-130		Production	B	
7	CP					87442	2	-	10-32 PHILIPS SCREW	W/PLASTIC WASHER	8					Production		
8	MA					25403X	2	-	ASSY, BRUSH TOP PANEL, HCS LITE - 40" DP.	NETWORK PARAMOUNT	2	51 - Vantage VS2				Production		X
9	SM					25404X	3	-	PANEL, BRUSH TOP - 40" DP. HCS LITE PARAM	FOR DBL. WD. RECT. TOP CUTOUT	1	50 - Paramount				Production	M	X
10	CR					99567	3	-	BRUSH STRIP - 3" WIDE, NYLON	8.31" LONG	2	Multiple Association	McMASTER-CARR			Production	M	X
11	CP					66714	2	H	SCREW, PAN HEAD SWAGEFORM	(OR EQUIVALENT)	4					Production	B	