

## Airflow Director Installation

This manual describes how to install an intake airflow director for rack-mounted switches. Each kit includes a top intake, side intake, and adjustable plate connecting the two intakes.

These instructions apply to the following Wright Line item numbers and Cisco or Juniper switches:

| Item Number | Application         |
|-------------|---------------------|
| AFDCSCO6506 | Cisco Switch 6506   |
| AFDCSCO6509 | Cisco Switch 6509   |
| AFDCSCO6513 | Cisco Switch 6513   |
| AFDCSCO6807 | Cisco Switch 6807   |
| AFDCSCO9513 | Cisco Switch 9513   |
| JNPR8208    | Juniper Switch 8208 |

### Prerequisites

- A Paramount or Vantage equipment rack or comparable third party enclosure.
- An installed Cisco switch, with a model number corresponding to the appropriate airflow director.
- At least 13.5 inches of clearance between the front and rear vertical rails.
- Unpack all components. Each kit contains a top intake, side intake, adjustable connecting plate, and fasteners.
- Make sure you have common installation tools including a #2 Philips screwdriver.

### Assemble top intake and connecting plate

Complete the following steps to assemble the top intake and adjustable connecting plate.

1. Position the connecting plate above the top intake. Align the slots in the connecting plate with the threaded screw holes in the top intake.

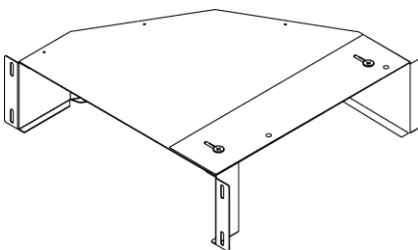
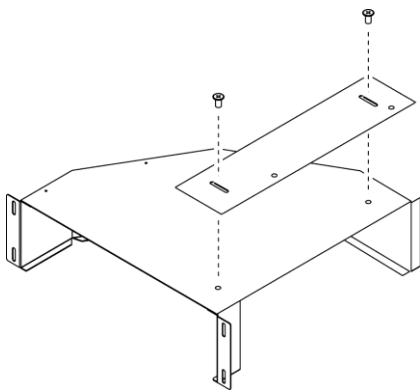
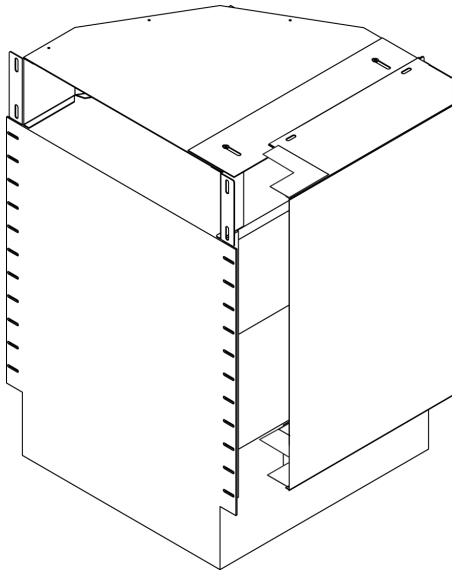

**Note:** The two screw holes in the connecting plate must be on the right side, with the holes closer to the rear, as shown.

2. Partially insert two 10-24 screws. Do not tighten. The connecting plate must be able to slide freely during installation.

## Install the airflow director

Complete the following steps to install the intake airflow director.

1. Position the top intake assembly on the switch as shown.

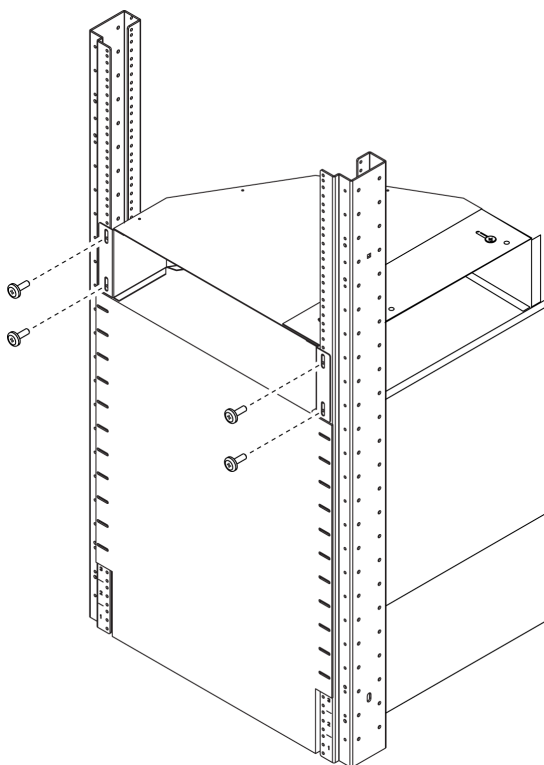
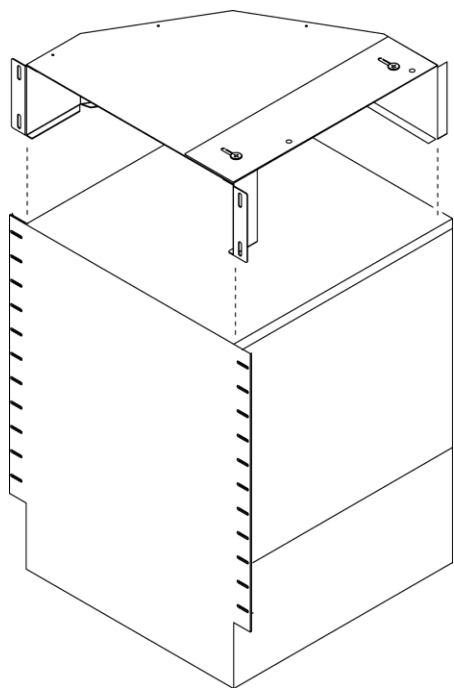

2. Using the included fasteners, insert four screws and/or nuts as needed to attach the top intake to the rails.

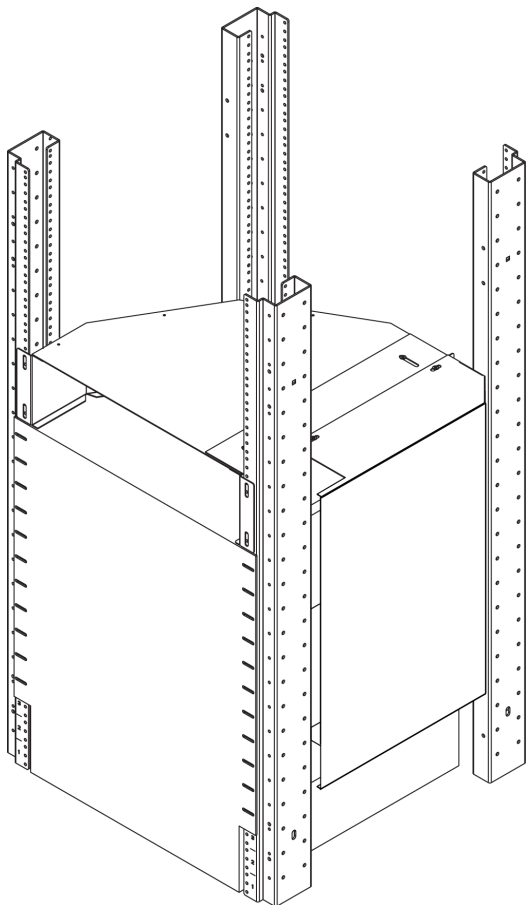

3. From above or below, position the side intake next to the switch between the right side rails. Make sure the switch intake is closely aligned with the side intake of the airflow director.

**Note:** The side intake requires at least 13.5 inches of clearance between the rails.

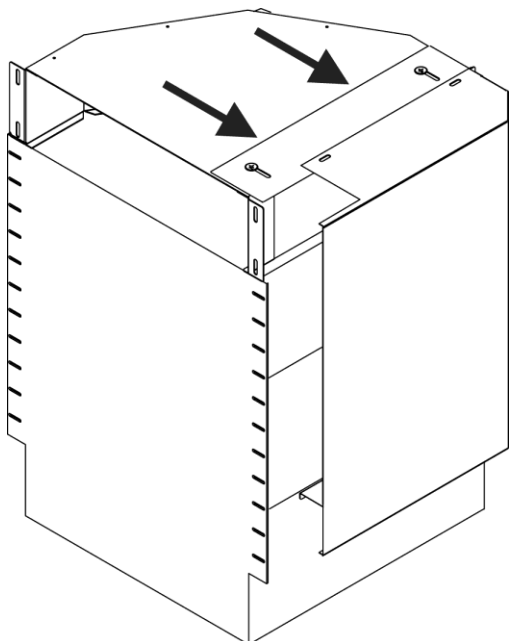

4. Slide the adjustable connecting plate under the top of the side intake. Align the slots in the top of the side intake with the screw holes in the connecting plate

**Note:** Make sure the connecting plate is below the top of the side intake. The connecting plate provides support for the side intake.

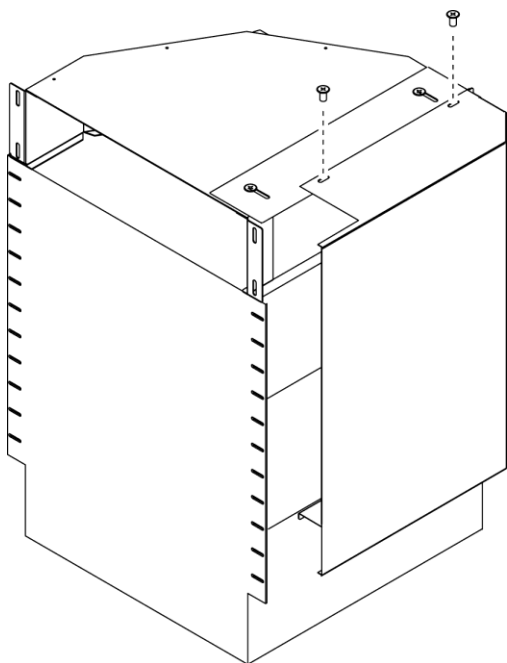

5. Insert two 10-24 screws through the slots on top of the side intake into the connecting plate and tighten.

6. Adjust the side intake as needed to make the best possible seal with the side of the switch.

7. Tighten the connecting plate screws.

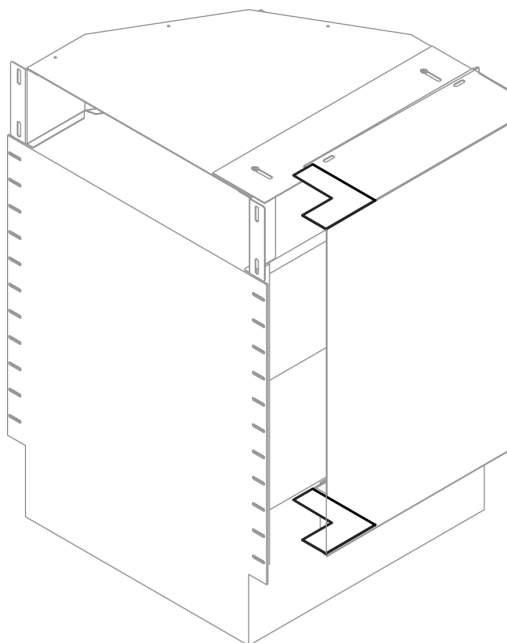

8. Fabricate the two plastic sheets as needed to form the best seal between the top and bottom of the side intake and the rail. Affix the fabricated seals.

**Airflow director installation is complete.**