

## Installation Guide

### Single Sliding End of Row Door

Publication No. MN160015EN

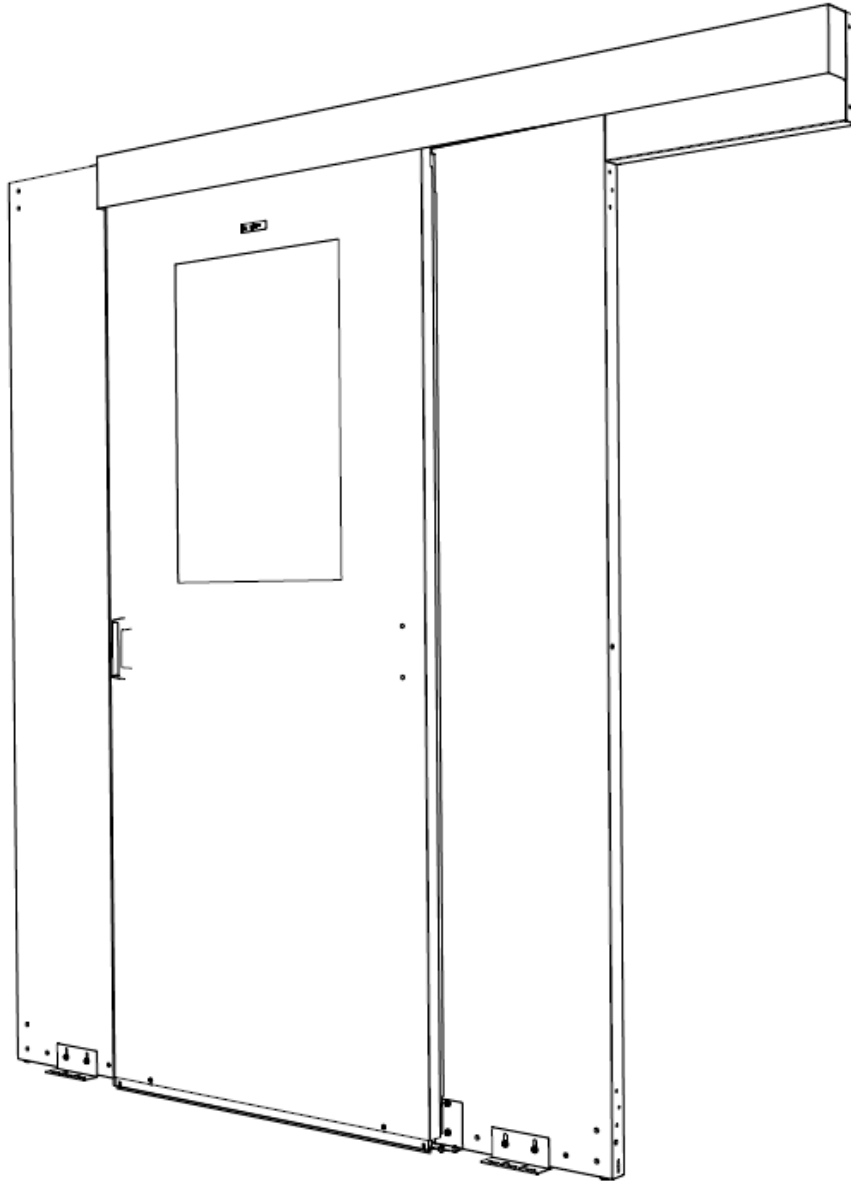

# Table of Contents

About this Guide .....	3
Intended Audience .....	3
Technical Support .....	3
Sales Representative and Contact Information .....	3
Before You Begin .....	3
Tools Required.....	3
Installation Best Practices.....	4
Dual Sliding End of Row Door Components - Detailed Descriptions.....	5
Jamb Wall Assemblies .....	5
Transom Assembly .....	6
Enclosure Brackets .....	6
Door Track Assemblies .....	6
Door Assemblies .....	7
Track Covers.....	7
Transom Covers.....	7
Dual Sliding End of Row Door Fasteners.....	8
Installing an Eaton Dual Sliding End of Row Door.....	9
Step 1: Prepare the Site .....	9
Step 2: Assemble the Jamb Walls.....	9,10,11,12
Step 3: Assemble the Transom .....	12
Step 4: Erect and Secure the Jamb Wall Assembly .....	13,14
Step 5: Install the Door Tracks .....	14,15,16
Step 6: Install the Doors .....	16,17,18
Step 7: Adjust the Door Seals .....	18,19
Step 8: Adjust the Automatic Door Closure Speed.....	19
Step 9: Install Covers .....	20
Accessories .....	21
Accessory Walls .....	21
Ceiling Hanger Attachment Bracket .....	21
Dual Sliding End of Row Door Maintenance .....	22

## About this Guide

This document contains general and detailed information about the installation, trouble shooting and care of Eaton's Single Sliding End of Row Door product.

### Intended Audience

This document is intended primarily for personnel responsible for installing and maintaining an Eaton Single Sliding End of Row Door.

### Technical Support

If you encounter any problems with this installation, send an email and detailed description of the problem as well as contact information to Technical Support at [dc.support@eaton.com](mailto:dc.support@eaton.com).

### Sales Representative and Contact Information

Contact your Eaton Sales representative using one of the methods below:

Phone	Call us toll free at 800.225.7348 (US Only) or 508.852.4300
Mail	Eaton 160 Gold Star Boulevard Worcester, MA 01606
Email	<a href="mailto:InfoESWorcesterMA@Eaton.com">InfoESWorcesterMA@Eaton.com</a>
Web	Visit us at <a href="http://www.eaton.com/wrightline">www.eaton.com/wrightline</a> and click on "Contact Us." Simply complete and submit the form as directed on our website.

### Before you Begin

Before installing an Eaton Single Sliding End of Row Door, it is recommended that you familiarize yourself with the various door components described within this document. Also, it would benefit installers to review the following section titled *Installation Best Practices and Helpful Hints* on page 3 of this installation guide.



### Tools Required

The following tools are required to complete the installation of an Eaton Single Sliding End of Row Door:

- A tape measure
- A chalk line (if allowed in your data center)
- A spirit level
- A powered screw gun/driver
- A 3/8" hex socket driver bit
- A Phillips head driver bit
- A 5/32" Allen wrench
- A 3/8" combination wrench
- A 7/16" combination wrench

## Installation Best Practices and Helpful Hints

This section contains an assortment of best practices and helpful hint topics that should be read before installing an Eaton Single Sliding End of Row Door.

<p><b>More Than a One Person Job</b></p>	<p>For reasons of safety and installation quality, it is highly recommended that two or more installers work together to complete the installation of an Eaton Sliding End-of-Row Door.</p>
<p><b>Anchoring Dual Sliding End of Row Door Components to the Floor</b></p>	<hr/> <p> <b>IMPORTANT!</b> If there is additional hardware required to complete the installation of the Dual Sliding End of Row Door (floor, wall, and/or ceiling anchoring support), and the specified hardware is NOT itemized and included on the door quote, then the required hardware must be included and priced by the Installation Team on the installation quote.</p> <hr/> <p>The hardware required for anchoring Single Sliding End-of-Row Door components to a facility floor depend upon the floor material. Anchoring hardware required for each facility is site specific and <b>MUST BE SPECIFIED AND/OR APPROVED</b> by facility management; preferably during the planning, design, and system ordering phase.</p> <p>When identifying anchoring hardware, take into consideration the type and length of anchoring screws used on a data center floor. The floor material may be steel, concrete, aluminum, or wood-core. The proper screw type and size should be used based on the floor material.</p> <hr/> <p> <b>IMPORTANT!</b> If prior to arrival, the installation team is not provided with details about the type of anchoring hardware required to conduct the installation, it is possible the team will arrive at the installation site without the necessary/proper anchoring hardware and the installation will be delayed until the proper anchoring hardware is either provided or acquired.</p> <hr/>
<p><b>Installation Accuracy</b></p>	<p>The Single Sliding End of Row Door is a mechanical device that is shipped partially disassembled. As such the quality of door operation and reliability will depend on the accuracy of installation. Specifically, the smooth operating characteristics of the door rely on accurate measuring, leveling, squareness and alignment of the field installed components.</p>

# Single Sliding End of Row Door Components - Detailed Descriptions

## Single Sliding End of Row Door Components

This section contains brief descriptions of the components used to construct an Eaton Single Sliding End of Row Door. These components can be set up for either a left hand or right hand opening door. Detailed installation instructions start on page 8.

### Jamb Wall Assemblies

Jam Wall Assemblies are the vertical structures that define the sides of the door opening.

A left hand and right hand Jamb Wall Assembly will be field assembled using the following sub-components:

**Walls:** The vertical support panels that are the basis for the Jamb Wall Assemblies.

**Track Extension:** The Track Extension supports the extended end of the door track.

**Vertical Door Channels:** Vertical Door Channels provide adjustable sealing surfaces that interface with the door's vertical perimeter seal gaskets.

**Floor Brackets:** Floor Brackets provide adjustable flanges that enable the Jamb Wall Assembly to be screwed to the data center floor. Floor Anchor Brackets are non-handed. There are two types of Floor Brackets available:

- Face Mount Floor Brackets
- Side Mount Floor Brackets

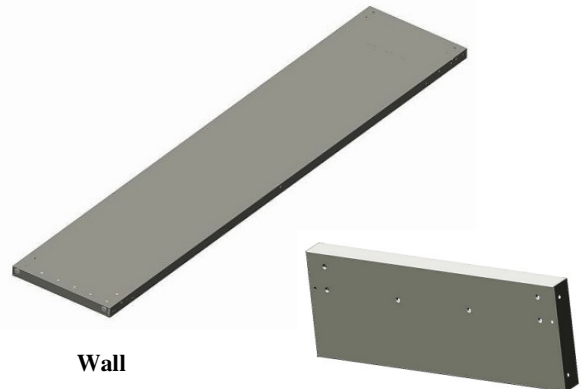

Wall

Track Extension

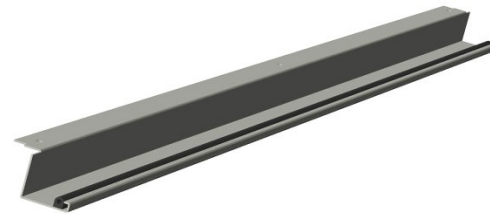

Vertical Door Stop Channel

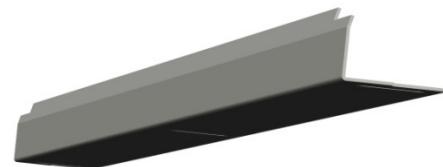

Vertical Door Seal Channel

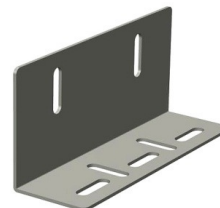

Face Mount Floor Bracket



Side Mount Floor Bracket

### Transom Assembly

The Transom Assembly is the horizontal structure that defines the top of the door opening.

The Transom Assembly will be assembled using the following sub-components:

**Transom:** The transom is the horizontal structure that defines the top of the door opening.

**Track Bracket:** The Track Bracket will support one end of the Door Track.

**Top Door Seal Channel:** The Top Door Seal Channel provides an adjustable sealing gasket that interfaces with the top of the door.



Transom Assembly



Top Door Seal Channel



Track Bracket

### Enclosure Brackets

The Enclosure Brackets provide adjustable attachment flanges that enable the Jamb Wall Assemblies to be attached to the tops of the data center's electronic rack enclosures.



Enclosure Bracket

### Door Track Assembly

The Door Track Assembly is the horizontal structure that supports the sliding door. The Door Track has an adjustable incline that enables the door to auto-return to a closed position.

The Door Track is shipped in a non-handed configuration. The Door Track will be field configured into either a right hand or left hand Door Track Assembly by attaching a Door Hold-open Retainer to one end of the Door Track.

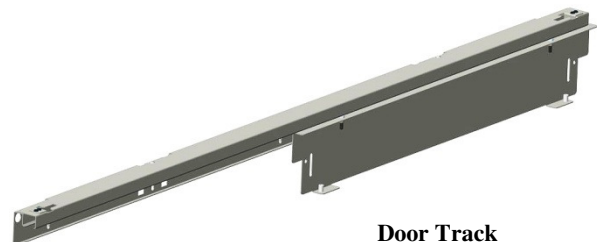

Door Track Assembly

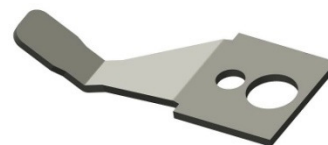

Door Hold-open Retainer

### Door Assembly

The Door Assembly is the sliding panel that closes off the door opening. The door can be configured to open either to the right or to the left. The Door Assembly will be field assembled using the following sub-components:

**Doors Panel:** The Door Panel will be field configured into either a right hand or a left hand opening Door Assembly by attaching the Door Handle to the appropriate side of the Door Panel.

### Door Handle

**Door Guide:** The Door Guide retains and guides the bottom of the sliding door. The door guide components will be field configured for either a right hand or a left hand opening door. The Door Guide is adjustable in or out, to enable vertical alignment of the door.

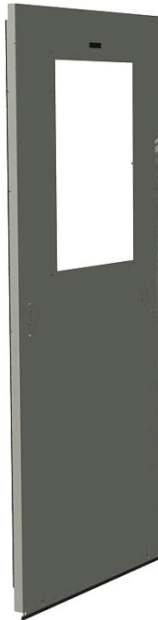

Door Assembly



Door Handle



Door Guide (RH configuration shown)

### Track Cover

The Track Cover hides the Door Track.

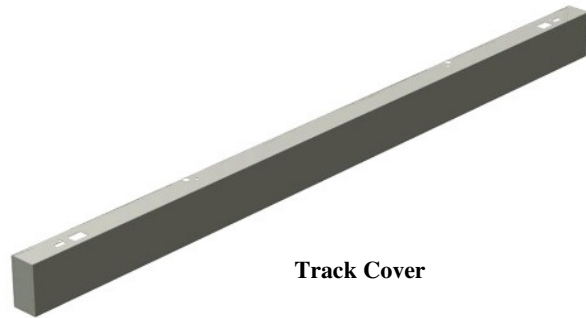

Track Cover





### Transom Cover

The Transom Cover finishes off the inside of the Transom Assembly and provides a sealing surface for other aisle containment products.



Transom Cover

## Single Sliding End of Row Door Fasteners

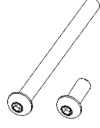
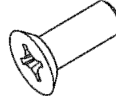
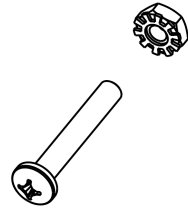
<p><b>1/4-20 Hex Head Self Threading Screw</b> (Part #54348)</p> <p>A 3/8" hex socket bit is required to install this screw.</p>	
<p><b>#10 x 3/8" Phillips Pan Head Self Threading Screw</b> (Part # 66714)</p> <p>A Phillips head bit is required to install this screw.</p>	
<p><b>1/4-20 Hex Keps Nut</b> (Part #18209)</p> <p>A 7/16" combination wrench is required to install this nut.</p>	
<p><b>1/4" Washer</b> (Part #18959)</p>	
<p><b>Allen Head Screws</b> (A 5/32" Allen wrench is required)</p> <p><b>1/4-20 x 3" Allen Head Screw</b> (Part #87464)</p> <p><b>1/4-20 x 5/8" Allen Head Screw</b> (Part #87398)</p>	
<p><b>#10 x 1/2" Phillips Flat Head Self Threading Screw</b> (Part #82555)</p> <p><i>(While these screws may be included in your hardware kit, they are not required for Single Sliding End of Row Doors.)</i></p>	
<p><b>Door Handle Fasteners</b></p> <p><b>#10-32 x 1-1/4" Phillips Head Machine Screw</b> (Part #93051) A Phillips head screwdriver is required to install this screw.</p> <p><b>#10 Hex Keps Nut</b> (Part #87693) A 3/8" hex socket driver bit is required to install this nut.</p>	



## Installing an Eaton Single Sliding End of Row Door

The Eaton Single Sliding End of Row Door components can be configured to provide a right hand or a left hand opening door.

For the purposes of this Installation Guide, a right hand opening door is defined as a door that slides open to the right, when viewed from the outside of the aisle. For a right hand opening door, the handle will be located near the left edge of the door. A right hand opening door is shown on the cover of this Installation Guide document.

**The following instructions are for a right hand opening door (as shown on the front page of this installation guide). For a left hand opening door, your assembly steps should mirror the images shown.**

### Step 1: Prepare the Site

1. Measure out 2" from each electronic rack and place marks on the floor.
2. Snap a chalk line on these two marks. This line represents the outer face of the Door Jamb Wall. (Note: if usage of a chalk line is not permitted in your data center, use another acceptable means to define this line.)
3. Mark two points on the line 36" apart to designate the desired position of the door opening width.

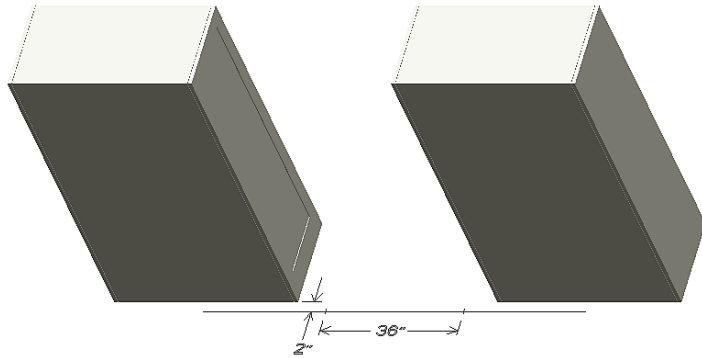

### Step 2: Assemble the Jamb Walls

#### Left hand Jamb Wall

1. Pre-install (2) 1/4-20 x 1/2" Hex Head Self Threading Screws into the Transom attachment holes on the right side of the Wall. Leave the screws protruding about 1/8".
2. Attach a Vertical Door Stop Channel to right side of the wall using (3) 1/4-20 x 1/2" Hex Head Self Threading Screws.
3. Pre-install a 1/4-20 x 1/2" Hex Head Self Threading Screw into the Track Cover attachment hole in the face of the Wall. Leave the screw protruding about 1/8".

*(Assembly Diagrams are on the next page.)*

*(Assemble the Left Hand Jamb Wall - continued next page)*

4. There are (2) different Floor Bracket styles available. Choose the appropriate instructions for your model.
  - a. Face Mounted Floor Brackets: Attach (1) bracket to the face of the Wall with (2) 1/4-20 x 1/2" Hex Head Self Threading Screws. Secure the bracket in its highest position.
  - b. Side Mounted Floor Brackets: Attach (1) bracket to each side of the Wall using (1) #10 x 3/8" Phillips Pan Head Self Threading Screw for each bracket. Secure the brackets in their highest position.
5. If it is necessary to seal the Jamb Walls to the electronic rack enclosures, apply the provided "D-bulb" gasket to the outer rear flange of the wall.

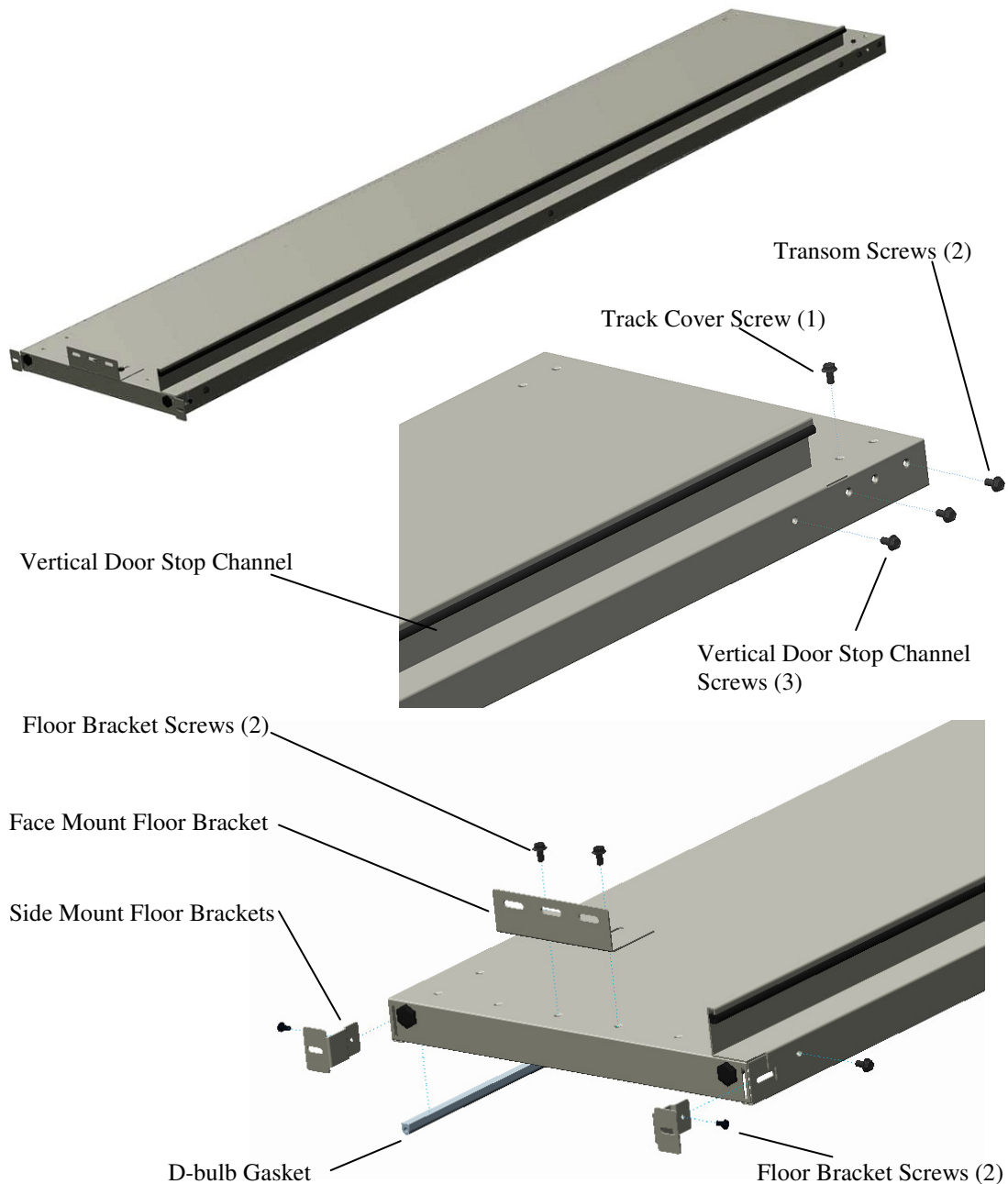

## Right Hand Jamb Wall

1. Attach a Track Extension to the right side of the wall with (2) 1/4-20 x 1/2" Hex Head Self Threading Screws.
2. Pre-install a 1/4-20 x 1/2" Hex Head Self Threading Track Cover Screw into the attachment hole in the Track Extension. Leave the screw protruding about 1/8".
3. Pre-install (2) 1/4-20 x 1/2" Hex Head Self Threading Screws into the Transom attachment holes on the left side of the Wall. Leave the screws protruding about 1/8".
4. Attach a Vertical Door Seal Channel to left side of the wall using (3) 1/4-20 x 1/2" Hex Head Self Threading Screws. Position the channel with the screws centered in the slots.
5. There are (2) different Floor Bracket styles available. Choose the appropriate instructions for your model.
  - a. Face Mounted Floor Brackets: Attach (1) bracket to the face of the Wall with (2) 1/4-20 x 1/2" Hex Head Self Threading Screws. Secure the bracket in its highest position.
  - b. Side Mounted Floor Brackets: Attach (1) bracket to each side of the Wall using (1) #10 x 3/8" Phillips Pan Head Self Threading Screw for each bracket. Secure the brackets in their highest position.
6. If it is necessary to seal the Jamb Walls to the electronic rack enclosures, apply the provided "D-bulb" gasket to the outer rear flange of the wall.

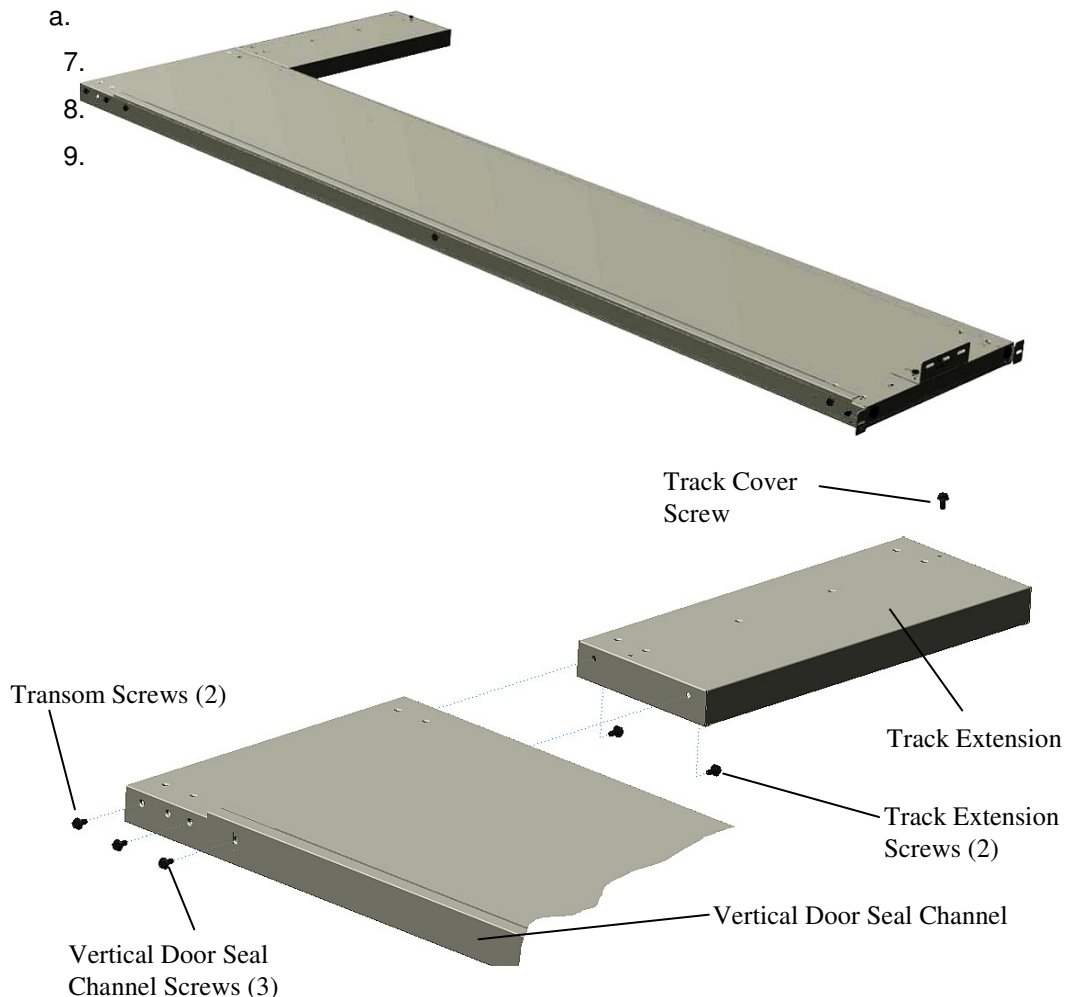

*(Assemble the Right Hand Jamb Wall - continued next page)*

(Assemble the Right Hand Jamb Wall - continued from previous page)

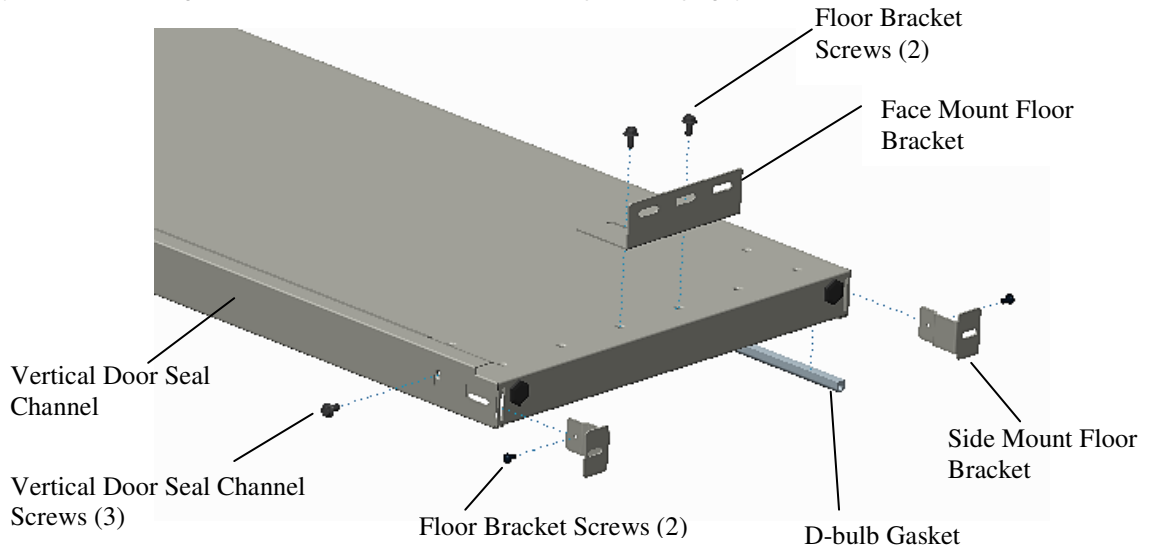

### Step 3: Assemble the Transom

1. Attach a Track Bracket to the left end of the Transom with (4) 1/4-20 x 1/2" Hex Head Self Threading Screws.
2. Attach the Top Door Seal Channel to the Transom with (3) 1/4-20 x 1/2" Hex Head Self Threading Screws. Position the channel with the screws centered in their slots.

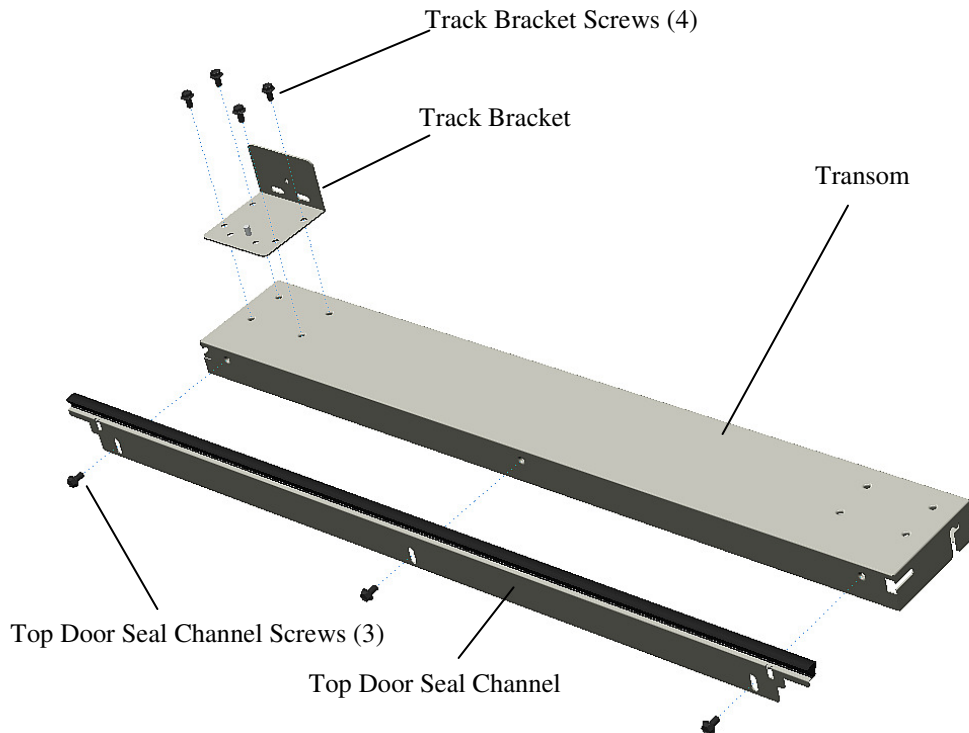

## Step 4: Erect and Secure the Jamb Wall Assembly *(This is a two person job.)*

### Erect the Jamb Wall Assembly

1. Ensure that the walls' leveling feet are fully retracted. Stand the left hand Jamb Wall, aligned with the chalk line and the mark that defines the door opening width.
2. Loosely attach the left hand Jamb Wall to the top of the electronic rack enclosure with an Enclosure Bracket. Attach the bracket to the wall in the most optimum position with (4) 1/4-20 x 1/2" Hex Head Self Threading Screws. Attach the bracket to the enclosure with appropriate fasteners. (\*See note below)
3. Roughly position the right hand Jamb Wall, and then engage the Transom Assembly onto the pre-installed Transom attachment screws on each Wall. Now tighten (4) the Transom attachment screws.
4. Loosely attach the right hand Jamb Wall to the adjacent electronic rack enclosure in the same manner as the left hand Jamb Wall.

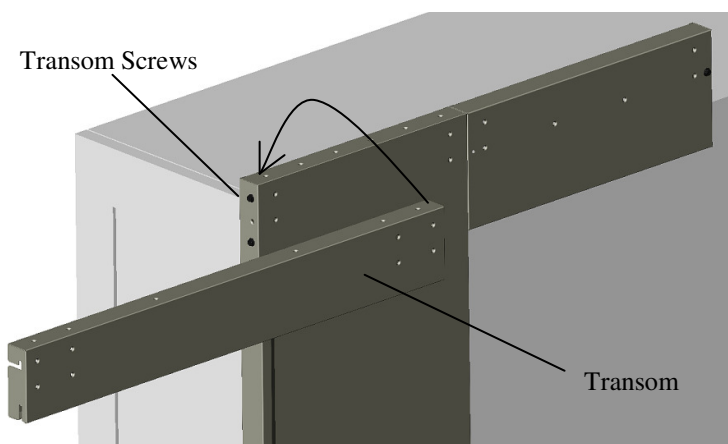
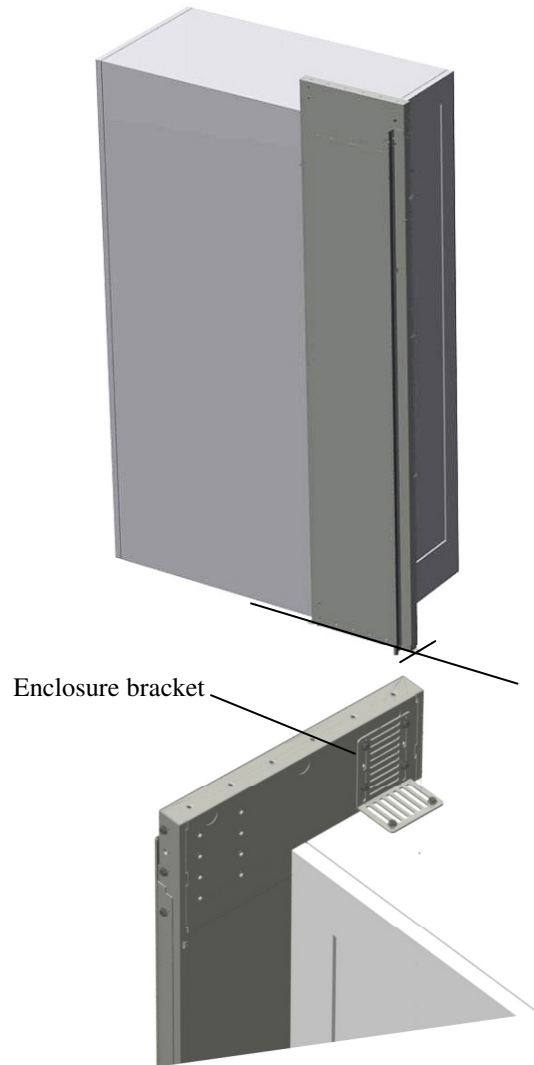

*(Erect the Jamb Wall Assembly - Continued on next page)*

\*Note: If direct attachment to the electronic rack enclosure is not permitted, a Ceiling Hanger Attachment Bracket (part number SCCI) is available. See page 20 for installation instructions.

5. Install a Tie Bar onto the top of the Jamb Wall Assembly at each Transom/Wall interface with (4) 1/4-20 x 1/2" Hex Head Self Threading Screws.

### Level and Secure the Jamb Wall Assembly

1. Verify that the Jamb Wall Assembly is level, planar, and aligned with the marks on the floor. Extend the Walls' leveling feet as required, but not more 3/4".

Then tighten the Enclosure Bracket screws.

2. Lower the Floor Anchor Brackets to the floor (if required) and then attach the brackets to the floor with appropriate fasteners for the site.

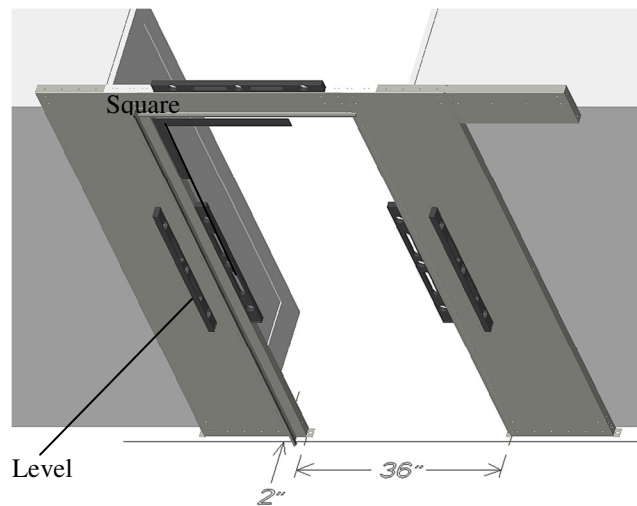
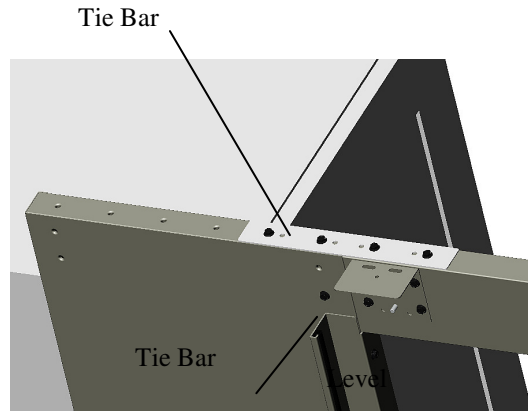

Failure to properly secure the Jamb Wall assembly to the electronic enclosures and to the floor will result in a potential tipping hazard which can cause serious injury.

### Step 5: Install the Door Track

#### Prepare the Door Track

Attach a Door Hold-open Retainer to the right end of the Door Track with (1) #10 x 3/8" Phillips Pan Head Self Threading Screw.

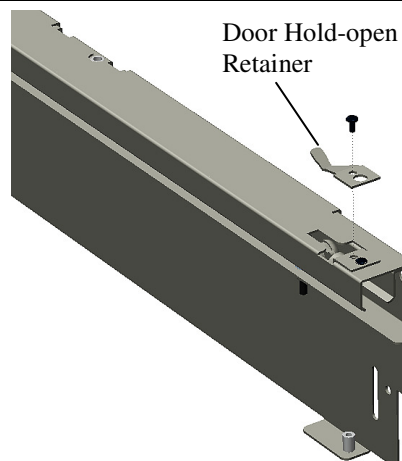

*(Install the Door Track - continued on next page)*

### Install the Remaining Track Bracket

Attach the remaining Track Bracket to the Jamb Wall and Track Extension with (4) 1/4-20 x 1/2" Hex Head Self Threading Screws.

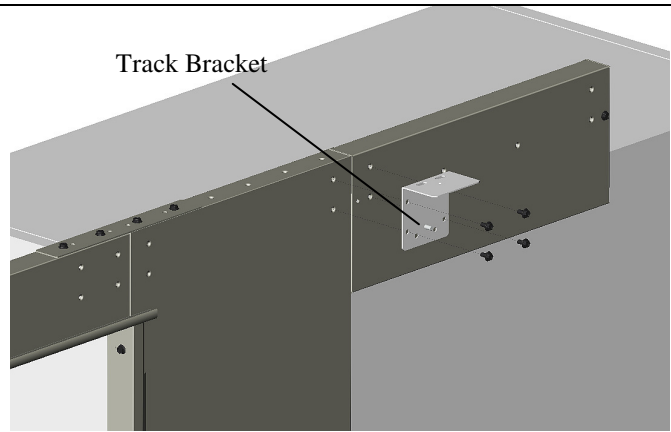

### Install the Door Track

1. Loosely attach the Door Track onto the Track Brackets' studs with (2) 1/4-20 Hex Keys Nuts.
2. Loosely install (2) 1/4-20 x 1/2" Hex Head Self Threading Screws, one into the Track Extension and one into the Transom.

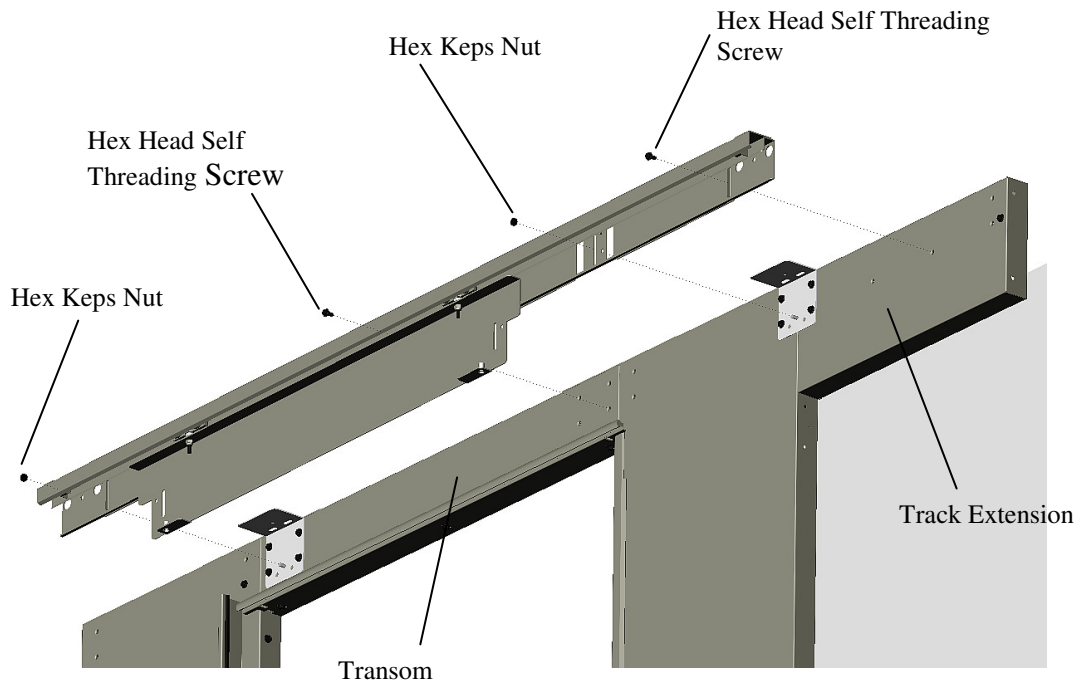

*(Installing the Door Track – continued on next page)*

*(Installing the Door Track – continued from previous page)*

1. Install a 1/4-20 x 3" Allen Head Track Adjustment Screw into the track's threaded insert near the right hand end of the track.
2. Using a 5/32" Allen Wrench, turn the adjustment screw to incline the Door Track until the Track's alignment hole aligns with the hole in the Track Bracket. Then tighten the (4) track attachment fasteners.

*(This incline is 1/2°, which should result in a moderate initial self closing door speed. The closure speed will be fine tuned at the end of the installation process by adjusting this angle.)*

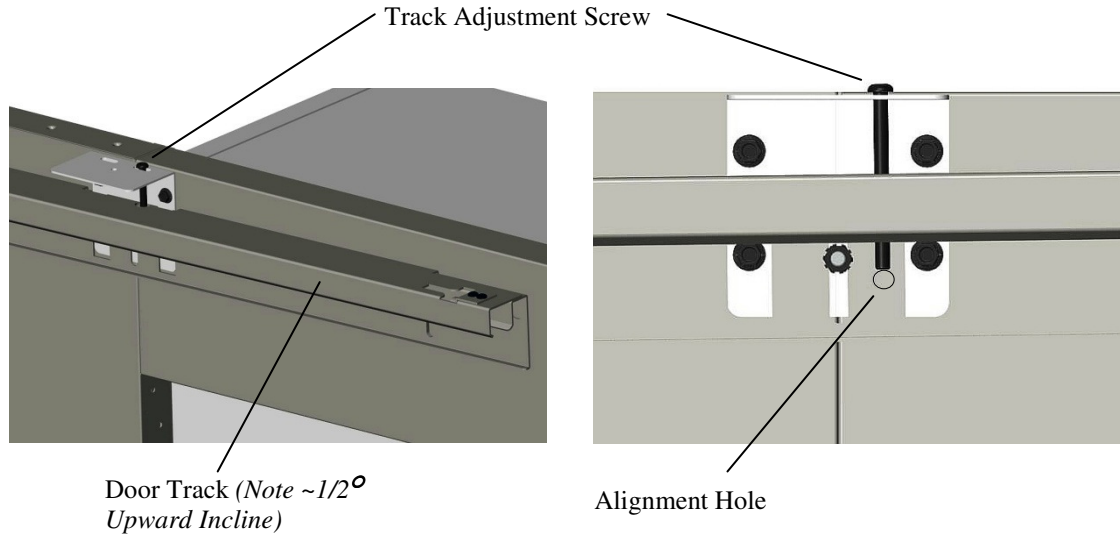

**Step 6: Install the Door** *(This is a two person job!)*

**Prepare the Door**

1. Remove and discard (2) small Hole Plugs from the left side of the door (as viewed from outside of the aisle).
2. Attach the Handle to the door with (2) #10-32 x 1-1/4" Phillips Head Machine Screws and (2) #10 Hex Keps Nuts.
3. Insert the Screw Cover into the Handle.
4. Insert (2) large Hole Plugs into the screw access holes.

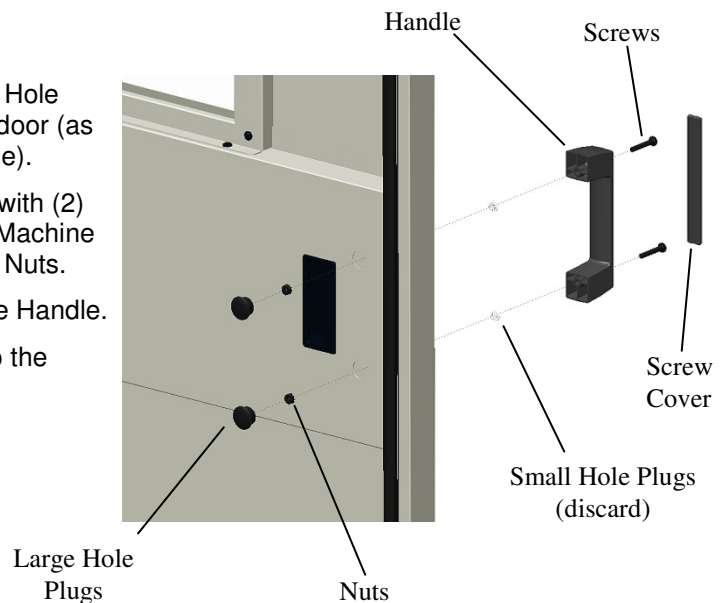



**Hang the Door** (This is a 2 person job!)

1. Have one person position the door (standing outside of the aisle), while a second person loosely attaches the door from inside the aisle with (2)  $\frac{1}{4}$ -20 x  $\frac{5}{8}$ " Allen Head Screws and (2)  $\frac{1}{4}$ " Washers. The handle edge of the door is attached to the Hanger Plate at the pivot hole. The opposite side of the door (towards the Track Extension) attaches to the plate at the oval adjustment slot.
2. Install (1)  $\frac{1}{4}$ -20 x 3" Allen Head Door Adjustment Screw and (1)  $\frac{1}{4}$ " Washer into the threaded insert in the Door Hanger Plate. Seat the screw head against the door's top frame member.
3. Using a  $\frac{5}{32}$ " Allen Wrench, turn the Door Adjustment Screw until the door is plumb, then tighten the door attachment screws.

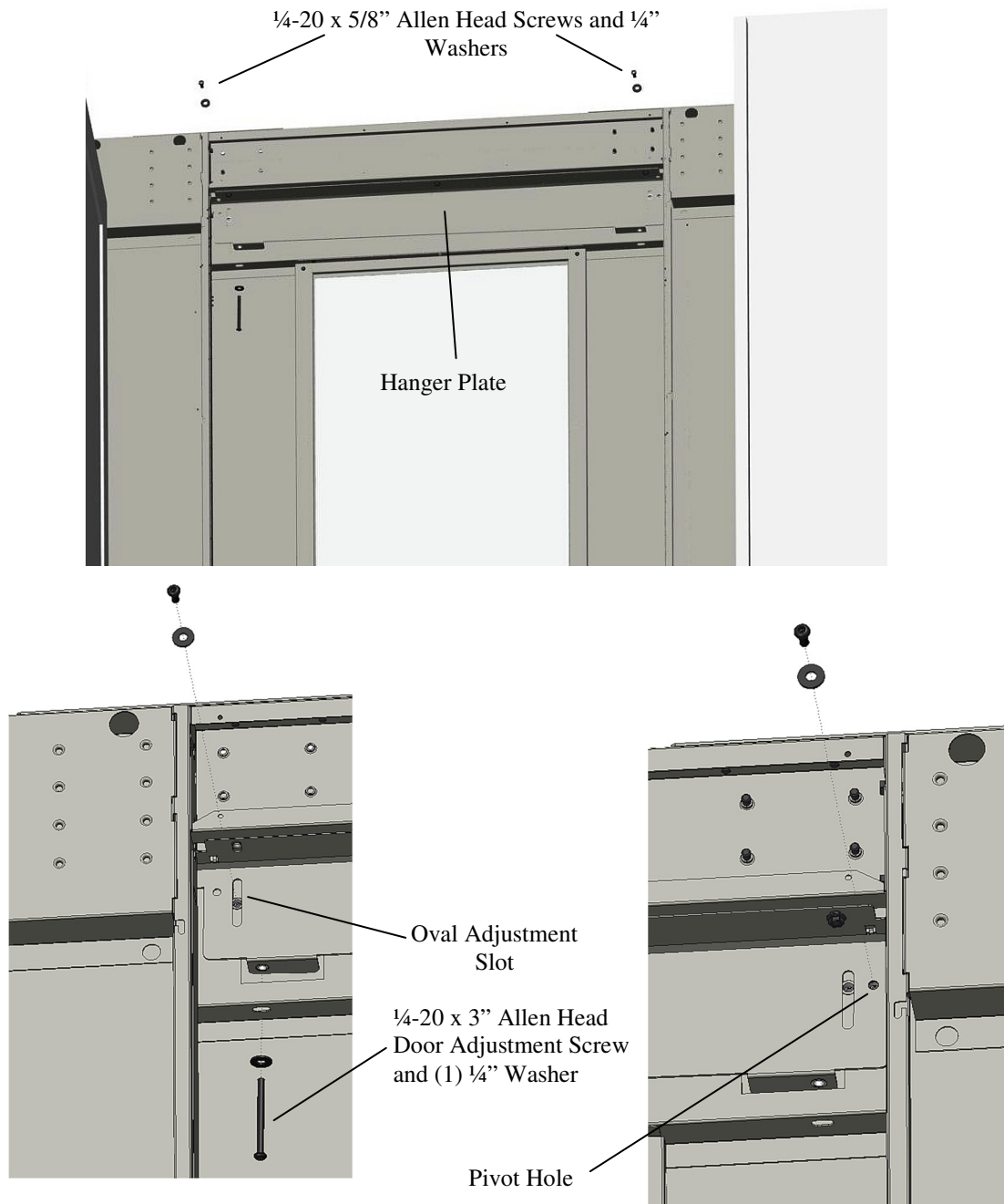

### Complete The Door Installation

1. Assemble the Door Guide as shown for a right hand opening door. *(Reverse the assembly for a left hand opening door.)*
2. Align the Adjustment Lever so that its "U" shaped cut is concentric with the unused threaded insert, and then tighten the (2) 1/4-20 x 3/8" Allen Head Screws. This is the Guide's neutral adjustment position.
3. Rotate the left hand Door Guide into place below the door, inserting the guide pin into the channel in the bottom of the door. Attach the Door Guide to the Wall with (2) 1/4-20 x 1/2" Hex Head Self Threading Screws. *(If required, adjust the Guide's lever in or out to plumb the door.)*

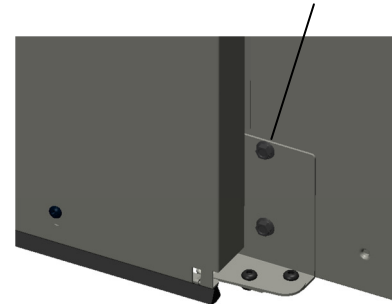
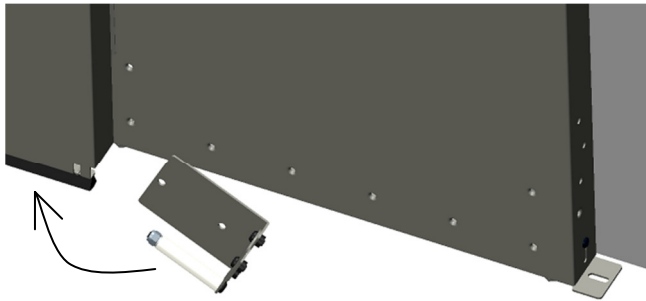
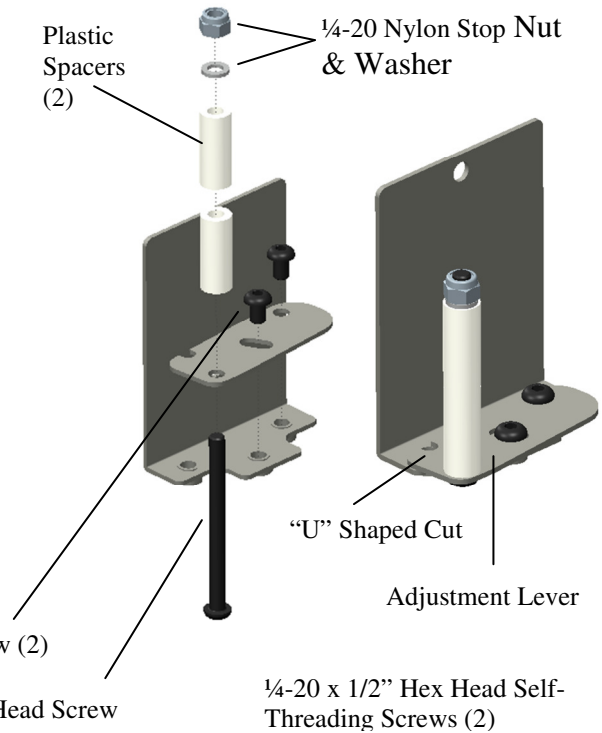

### Step 7: Adjust the Door Perimeter Seals

When properly adjusted, the door perimeter seals should not hinder the self closing speed of the doors.

1. Adjust the position of the Vertical Door Seal Channel so that its contact surface barely touches the pile gasket on the door.

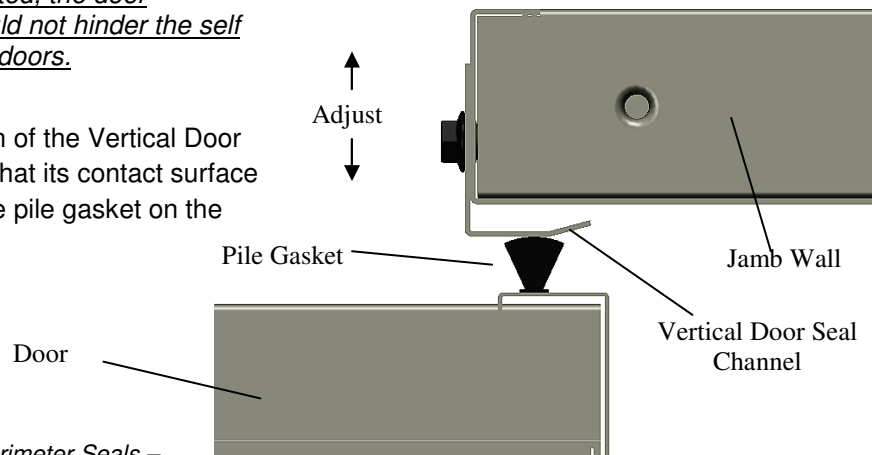

(Adjust the Door Perimeter Seals – continued on next page)

Top View of Door

*(Adjust the Door Perimeter Seals – continued from previous page)*

2. Adjust the position of the Top Door Seal Channel so that the pile gasket barely touches the rear door surface.
3. With the door fully closed, adjust the position of the Bottom Door Seal Channel so that the pile gasket barely touches the floor.

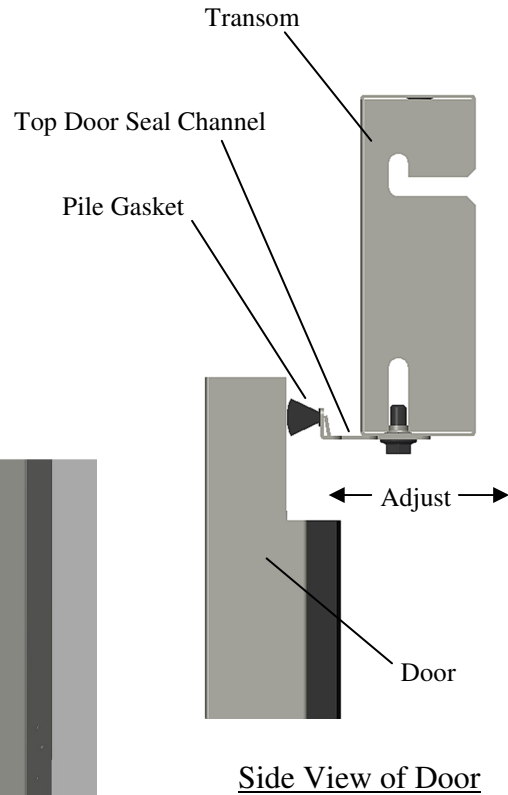
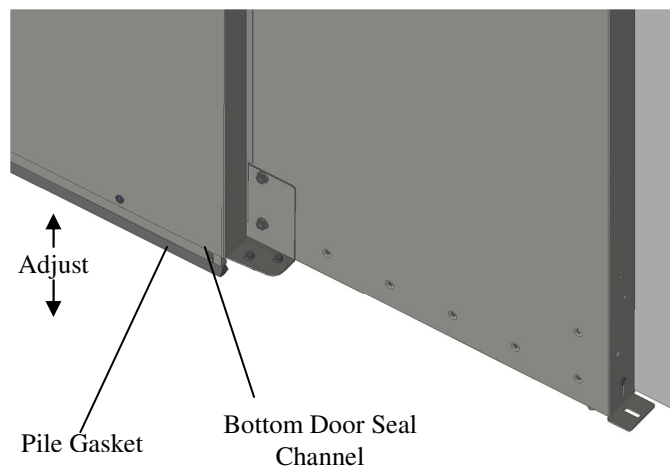

## Step 8: Adjust Door Automatic Closure Speed

1. Open the door fully and then allow it to self-close. The door closure speed should be as slow as possible while still ensuring that the door always fully closes. (While the door may rebound slightly, its closure should be adjusted so that the door always returns to its fully closed position.)
2. Adjust the incline of the track as required by loosening the track's (4) attachment points and then turning the Track Adjustment Screw. Retighten the (4) track attachment points when the desired closure speed is attained.
3. If the track incline is adjusted, it may be necessary to loosen the door attachment screws to re-level the door. Ensure that the door seats against the Door Stop Channel's "D-Bulb" gasket along the entire height of the door.

## Step 9: Install Covers

### Install the Track Covers

1. Note: Track Cover attachment screws were pre-installed in earlier steps.
2. To install the Track Cover, position the cover onto the top of the Track Brackets, engaging the key-hole slots at each end of the cover with the previously installed screws. Install (2) 1/4-20 x 1/2" Hex Head Self Threading Screws into the Track Brackets to secure the cover.

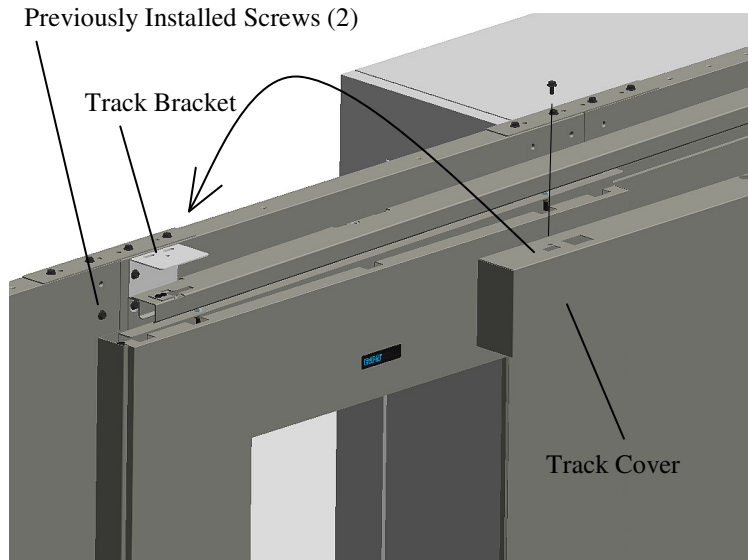

### Install the Inner Transom Cover

Attach the Inner Transom Cover to the Transom with (8) #10x3/8" Phillips Pan Head Self Threading Screws.

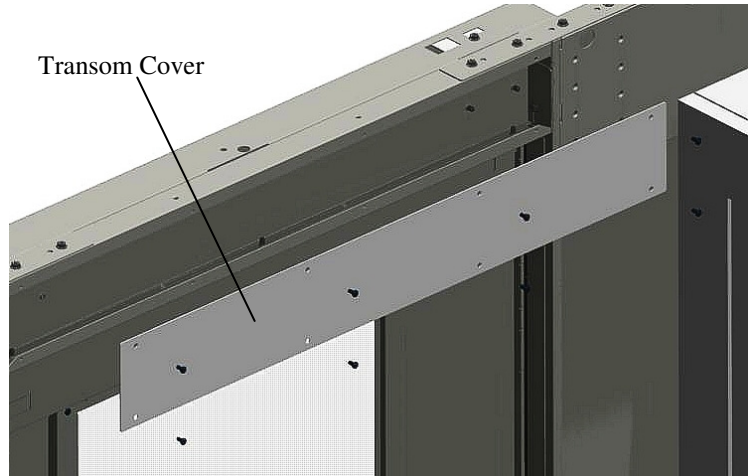

### Install the Inner Door Cover

Insert the hooks on the cover into the slots in the door. Push the cover upwards to seat the hooks. Secure the cover with (1) #10x3/8" Phillips Pan Head Self Threading Screw.

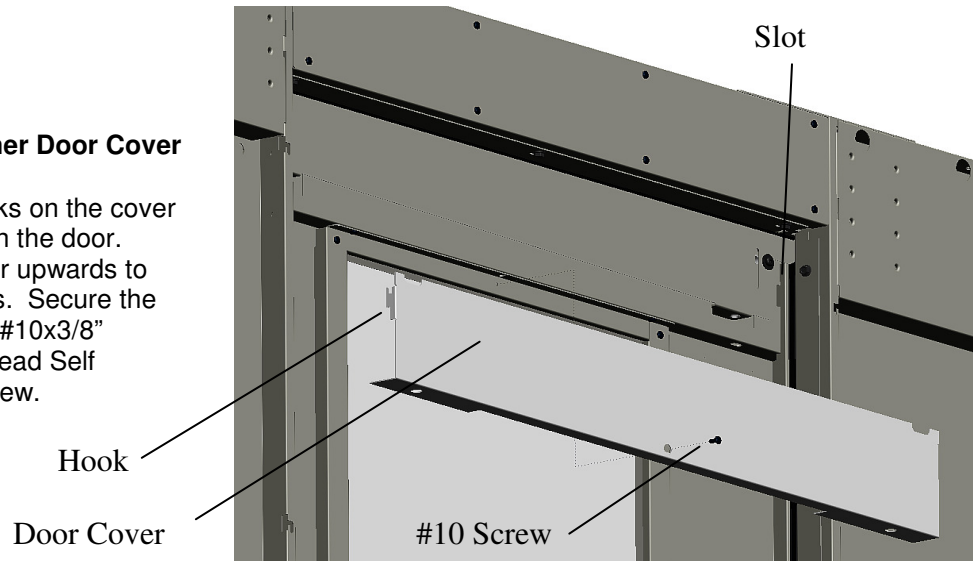

## Accessory Walls

Accessory Walls are available in 6", 9", 12" & 24" widths. Accessory Walls can be joined to the existing Jamb Wall to make a wider Jamb Wall Assembly.

If required, remove the Track Extension that supports the end of the Door Track (see page 10).

Join the Accessory Wall to the existing Jamb Wall using (1) Tie Bar, (1) Floor Anchor Bracket and (6) 1/4- 20 x 1/2" Hex Head Self Threading Screws.

Re-attach the Door Track to the newly added Accessory Wall. Depending on the Accessory Wall width, it may be necessary to drill a .218 diameter hole in the wall in order to re-attach the Door Track as it was originally attached to the Track Extension.

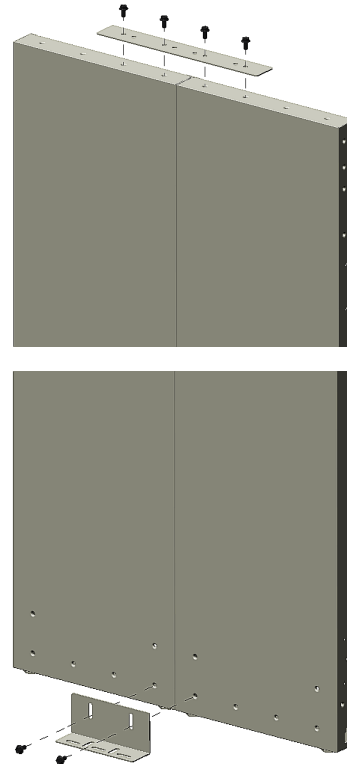

## Ceiling Hanger Attachment Bracket (part #SCCI)

If direct attachment to the electronic rack enclosure is not permitted, a Ceiling Hanger Attachment Bracket (part number SCCI) is available.

The Stud Plate that is included with the SCCI Bracket Kit is not required for this application. Attach the bracket directly to the back of the Jamb Wall with (2) 1/4- 20 x 1/2" Hex Head Self Threading Screws.

Attach your threaded rod to the "U" slots in the bracket with appropriate washers and nuts.

Additional lateral support is recommended, as shown, to prevent swaying of the Jamb Wall Assembly.

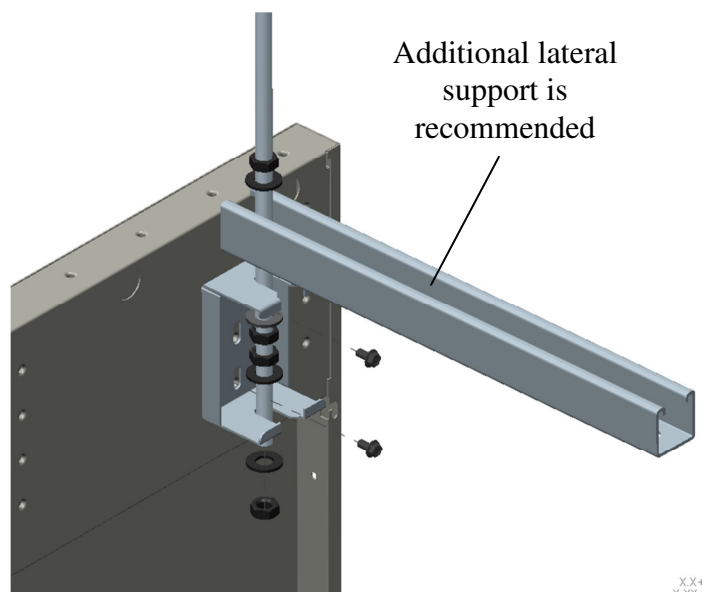

X.X+0.5  
Y.YX+0.1

## Single Sliding End of Row Door Maintenance

This section describes how to care for your Eaton Single Sliding End of Row Door by performing regular maintenance. Regular maintenance will ensure trouble free operation of your door and efficient aisle containment.

### Routine Inspection and Cleaning As Needed

Conduct routine inspections on your door and perform necessary cleaning tasks as needed. Refer to the following table for routine tasks.

Inspect the free travel of the sliding door. The Door should slide freely and come to a gentle stop against the end stop “D-bulb” bumper strip. If not, adjust the door’s track incline (see page 15) and perimeter seals (see pages 17 and 18).

<b>Task</b>	<b>Frequency</b>	<b>Tools and Supplies</b>
Clean Door Guides	Monthly	Clean with a damp cloth. Dry with a clean, dry cloth.
Clean Door Tracks	Monthly	Clean with a damp cloth. Dry with a clean, dry cloth.  A light application of silicone lubricant may be applied to the angled roller support flanges using a clean lightly saturated cloth.
Clean Windows	As required	Clean with a non-solvent window cleaner approved for Lexan and Plexiglas.
Tighten all exposed screws and bolts	Annually	Refer to the <i>Single Sliding End of Row Door Fasteners</i> section on page 6 of this Installation Guide.
Adjust Door Perimeter Seals	Annually, or as required	Refer to pages 14 and 15 of this Installation Guide.
Adjust door automatic closure speed	Annually, or as required	Refer to pages 12, 13, 14 and 15.

Information in this document is subject to change without notice. No part of this document may be reproduced or transmitted in any form or by any means, electronic or mechanical, for any purpose, without the express written consent of Eaton.

Eaton is a registered trademark of Eaton or its subsidiaries and affiliates. Phillips is a registered trademark of Phillips Screw Company. All other trademarks are the property of their respective owners.

**Eaton**  
Electrical Sector  
1000 Eaton Boulevard  
Cleveland, OH 44122 USA  
Eaton.com

© 2015 Eaton  
All Rights Reserved  
MN160015EN  
May 2015

**To contact an Eaton salesperson  
or local distributor, please visit  
[www.eaton.com/wrightline](http://www.eaton.com/wrightline) or  
call 800-225-7348.**

**EATON**

*Powering Business Worldwide*