

## Installation Guide

### Dual Swing End of Row Door

Publication No. MN160017EN



# Table of Contents

About this Guide .....	3
Intended Audience .....	3
Technical Support .....	3
Sales Representative and Contact Information .....	3
Before You Begin .....	3
Tools Required.....	3
Installation Best Practices.....	4
Dual Swing End of Row Door Components - Detailed Descriptions .....	5
Jamb Walls.....	5
Floor Anchor Brackets.....	5
Hinge Components .....	5
Enclosure Brackets .....	5
Transom .....	5
Inner Transom Cover .....	6
Door Components .....	6
Dual Swing End of Row Door Fasteners .....	6
Installing an Eaton Dual Swing End of Row Door .....	7
Step 1: Prepare the Site .....	7
Step 2: Pre-assemble the Jamb Walls .....	7,8
Step 3: Erect and Secure the Jamb Wall.....	9,10
Step 4: Install the transom Cover .....	11
Step 5: Install the Doors .....	11,12,13
Step 6: Adjust the Doors' Bottom Seals .....	13
Accessories .....	14
Accessory Walls.....	14
Ceiling Hanger Attachment Bracket .....	14
Dual Swing End of Row Door Maintenance .....	15

## About this Guide

This document contains general and detailed information about the installation, trouble shooting and care of Eaton's Dual Swing End of Row Door product.

### Intended Audience

This document is intended primarily for personnel responsible for installing and maintaining an Eaton Dual Swing End of Row Door.

### Technical Support

If you encounter any problems with this installation, send an email and detailed description of the problem as well as contact information to Technical Support at [dc.support@eaton.com](mailto:dc.support@eaton.com).

### Sales Representative and Contact Information

Contact your Eaton Sales representative using one of the methods below:

Phone	Call us toll free at 800.225.7348 (US Only) or 508.852.4300
Mail	Eaton 160 Gold Star Boulevard Worcester, MA 01606
Email	<a href="mailto:InfoESWorcesterMA@Eaton.com">InfoESWorcesterMA@Eaton.com</a>
Web	Visit us at <a href="http://www.eaton.com/wrightline">www.eaton.com/wrightline</a> and click on "Contact Us." Simply complete and submit the form as directed on our website.

### Before you Begin

Before installing an Eaton Dual Swing End of Row Door, it is recommended that you familiarize yourself with the various door components described within this document. Also, it would benefit installers to review the following section titled *Installation Best Practices and Helpful Hints* on page 3 of this installation guide.



### Tools Required

The following tools are required to complete the installation of an Eaton Dual Swing End of Row Door:

- A tape measure
- A chalk line (if allowed in your data center)
- A spirit level
- A powered screw gun/driver
- A 3/8" hex socket driver bit
- A Phillips head driver bit

## Installation Best Practices and Helpful Hints



This section contains an assortment of best practices and helpful hint topics that should be read before installing an Eaton Dual Swing End of Row Door.

<p><b>More than a One Person Job</b></p>	<p>For reasons of safety and installation quality, it is highly recommended that two or more installers work together to complete the installation of an Eaton Dual Swing End-of-Row Door.</p>
<p><b>Anchoring Dual Sliding End of Row Door Components to the Floor</b></p>	<hr/> <p> <b>IMPORTANT!</b> If there is additional hardware required to complete the installation of the Dual Swing End of Row Door (floor, wall, and/or ceiling anchoring support), and the specified hardware is NOT itemized and included on the door quote, then the required hardware must be included and priced by the Installation Team on the installation quote.</p> <hr/> <p>The hardware required for anchoring Dual Swing End-of-Row Door components to a facility floor depend upon the floor material. Anchoring hardware required for each facility is site specific and <b>MUST BE SPECIFIED AND/OR APPROVED</b> by facility management; preferably during the planning, design, and system ordering phase.</p> <p>When identifying anchoring hardware, take into consideration the type and length of anchoring screws used on a data center floor. The floor material may be steel, concrete, aluminum, or wood-core. The proper screw type and size should be used based on the floor material.</p> <hr/> <p> <b>IMPORTANT!</b> If prior to arrival, the installation team is not provided with details about the type of anchoring hardware required to conduct the installation, it is possible the team will arrive at the installation site without the necessary/proper anchoring hardware and the installation will be delayed until the proper anchoring hardware is either provided or acquired.</p> <hr/>
<p><b>Installation Accuracy</b></p>	<p>The Dual Swing End of Row Door is a mechanical device that is shipped partially disassembled. As such the quality of door operation and reliability will depend on the accuracy of installation. Specifically, the smooth operating characteristics of the door rely on accurate measuring, leveling, squareness and alignment of the field installed components.</p>

## Dual Swing End of Row Door Components - Detailed Descriptions

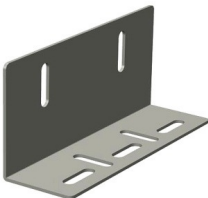
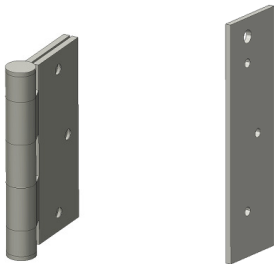

### Dual Swing End of Row Door Components

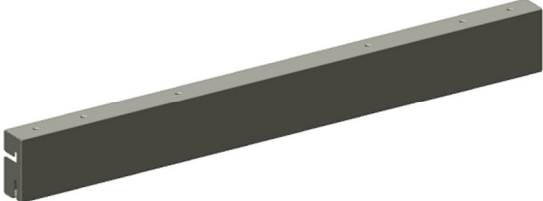
This section contains brief descriptions of the components used to construct an Eaton Dual Swing End of Row Door. Detailed installation instructions start on page 6.

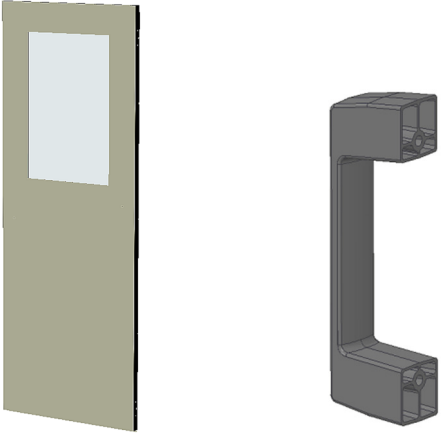
<p><b>Jamb Walls</b></p> <p>Jamb Walls are the vertical structures that define the sides of the door opening. The Jamb Walls, as shipped, are non-handed. You will build left hand and right hand Jamb Wall assemblies using the components provided.</p>	
<p><b>Floor Anchor Brackets</b></p> <p>Floor Brackets provide adjustable flanges that enable the Jamb Wall Assembly to be screwed to the data center floor.</p>	
<p><b>Hinge Components</b> (Hinge and Backing Plate)</p> <p>The Hinge Backing Plate reinforces the attachment of the Hinge to the Jamb Wall.</p>	
<p><b>Enclosure Brackets</b></p> <p>The Enclosure Brackets provide adjustable attachment flanges that enable the Jamb Walls to be attached to the tops of the data center's electronic rack enclosures.</p>	
<p><b>Transom</b></p> <p>The Transom is the horizontal structure that defines the top of the door opening.</p>	

<p><b>Transom Cover</b></p> <p>The Transom Cover finishes off the inside of the Transom and provides a sealing surface for other aisle containment products. The Transom Cover also has a pre-installed pile gasket that seals against the door's rear surface.</p>	
<p><b>Door Components</b></p> <p>Door Panels - Pre-configured left hand and right hand door panels are provided. The left hand and right hand door panels are indicated with punched letters "L" and "R" on the back of the doors, near the top.</p> <p>Door Handles – Door Handles ship un-assembled to prevent shipping damage.</p>	

### Dual Swing End of Row Door Fasteners

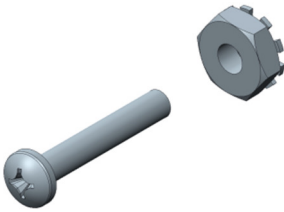
<p><b>#10x 1/2" Phillips Flat Head Self Threading Screw</b> (Part # 63832)</p> <p>A Phillips head bit is required to install this screw.</p>	
<p><b>1/4-20 x 1/2" Hex Head Self Threading Screw</b> (Part #54348)</p> <p>A 3/8" hex socket bit is required to install this screw.</p>	
<p><b>#10 x 3/8" Phillips Pan Head Self Threading Screw</b> (Part # 66714)</p> <p>A Phillips head bit is required to install this screw.</p>	
<p><b>Door Handle Fasteners</b></p> <p><b>#10-32 x 1-1/4" Phillips Head Machine Screw</b> (Part #93051) A Phillips head screwdriver is required to install this screw.</p> <p><b>#10 Hex Keps Nut</b> (Part #87693) A 3/8" hex socket driver bit is required to install this nut.</p>	

# Installing an Eaton Dual Swing End of Row Door

## Step 1: Prepare the Site

1. Measure out 2" from each electronic rack and place marks on the floor.
2. Snap a chalk line on these two marks. This line represents the outer face of the Jamb Wall.  
(Note: if usage of a chalk line is not permitted in your data center, use another acceptable means to define this line.)
3. Mark two points on the line 48" apart to designate the desired position of your door opening width.

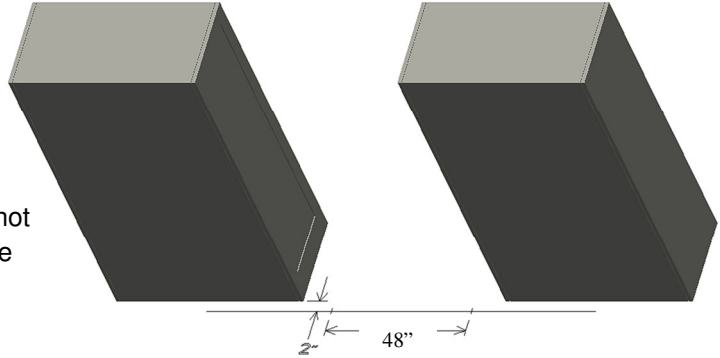

## Step 2: Pre-assemble the Jamb Walls

### Pre-assemble the Left Hand Jamb Wall

1. Attach (2) Hinges to the right side of the Jamb Wall (as viewed from outside of the aisle) using (3) #10 x 1/2" Phillips Flat Head Self Threading Screws and (1) Backing Plate for each Hinge. The Hinges MUST be oriented with their removable pins pointing upwards.
2. If it is necessary to seal the Jamb Walls to the electronic rack enclosures, apply one half of the provided 'D-bulb' gasket to the left rear edge of the Jamb Wall (as viewed from outside of the aisle).

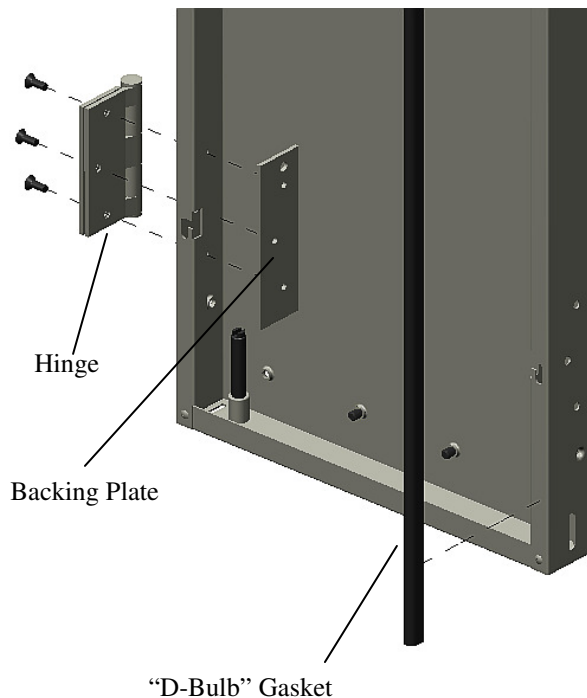

*(Pre-assemble the Left Hand Jamb Wall continued on next page)*

**Pre-assemble the Left Hand Jamb Wall  
(continued)**

3. Attach (1) Floor Anchor Bracket to the face of the Jamb Wall with (2) 1/4-20 x 1/2" Hex Head Self Threading Screws. Secure the bracket in its highest position.
4. Pre-install (2) 1/4-20 x 1/2" Hex Head Self Threading Screws into the top two Transom attachment holes on the right side of the Wall. Leave the screws protruding about 1/8".

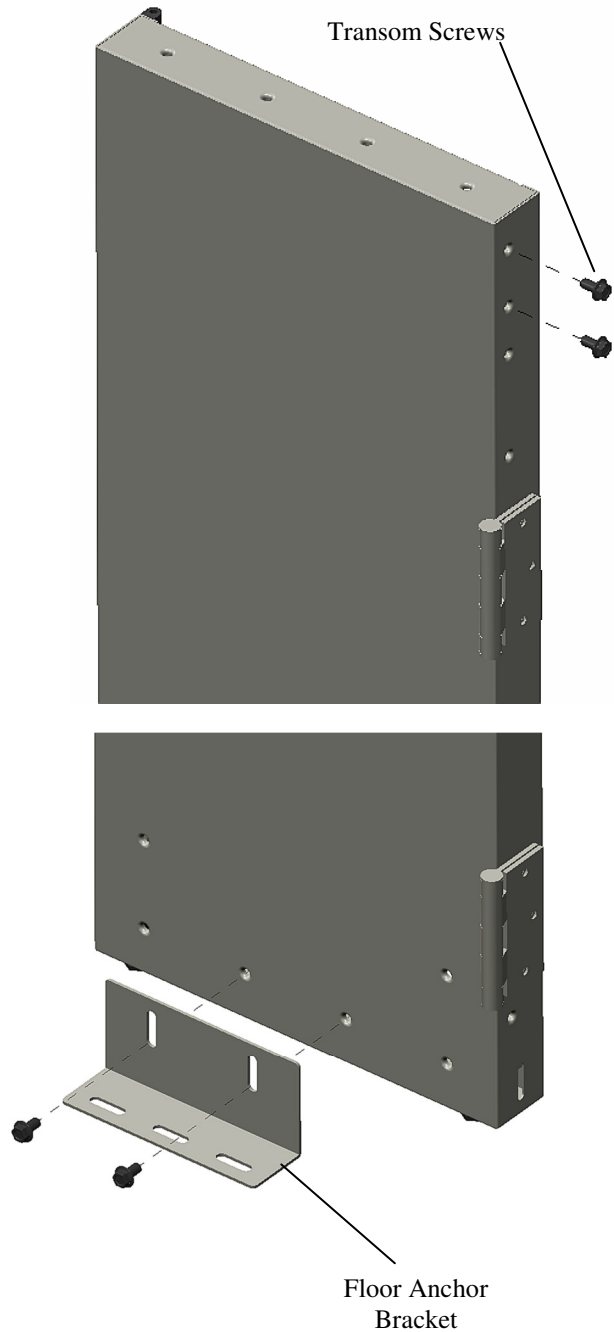

**Pre-assemble the Right Hand Jamb Wall**

Assemble a mirror image of the left hand Jamb Wall using the previous section as a guide.



### Step 3: Erect and Secure the Jamb Wall Assembly *(This is a two person job.)*

1. Ensure that the walls' leveling feet are fully retracted. Stand the left hand Jamb Wall, aligned with the chalk line and the mark that defines the door opening width.
2. Loosely attach the left hand Jamb Wall to the top of the electronic rack enclosure with an Enclosure Bracket. Attach the bracket to the wall in the most optimum position with (4) 1/4-20 x 1/2" Hex Head Self Threading Screws. Attach the bracket to the enclosure with appropriate fasteners. (\*See note below.)
3. Roughly position the right hand Jamb Wall, and then engage the Transom Assembly onto the pre-installed Transom attachment screws on each Wall. Now tighten (4) the Transom attachment screws.
4. Loosely attach the right hand Jamb Wall to the adjacent electronic rack enclosure in the same manner as the left hand Jamb Wall.

\*Note: If direct attachment to the electronic rack enclosure is not permitted, a Ceiling Hanger Attachment Bracket (part number SCCI) is available. See page 13 for installation instructions.

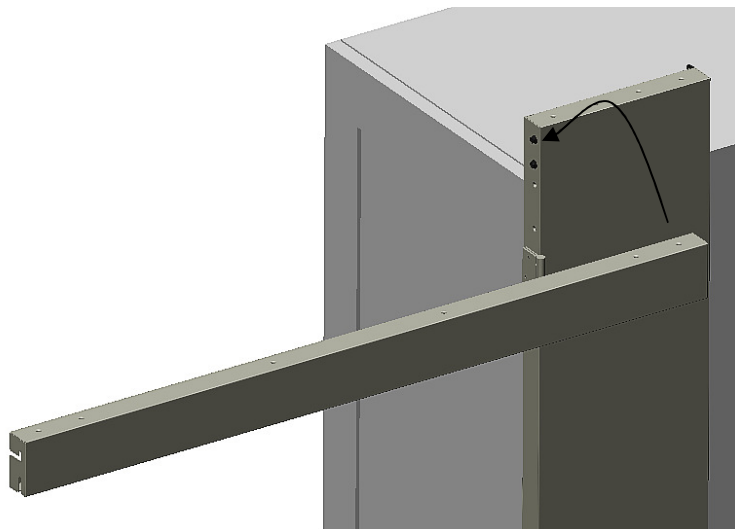
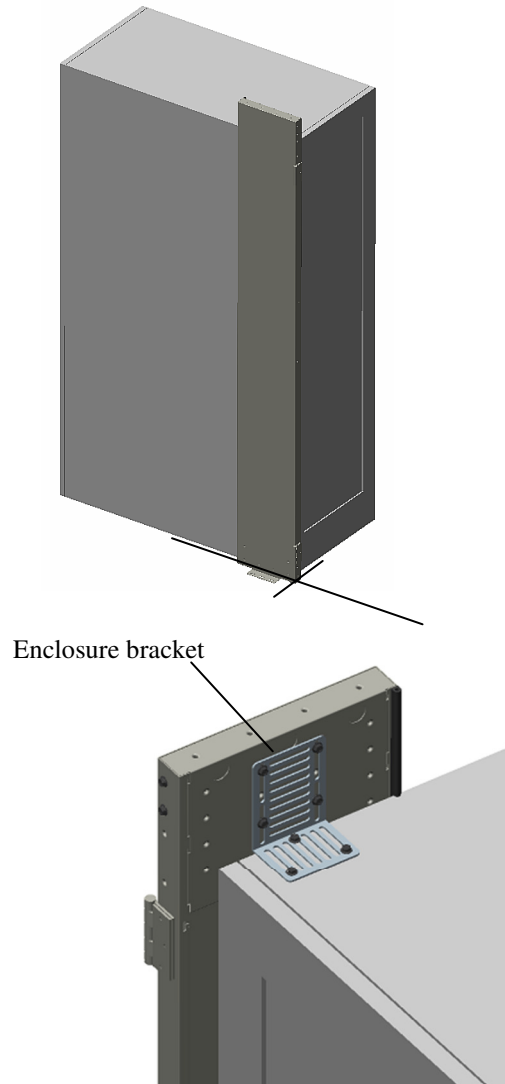

5. Install a Tie Bar onto the top of the Jamb Wall Assembly at each Transom/Wall interface with (4) 1/4- 20 x 1/2" Hex Head Self Threading Screws.

**Level and Secure the Jamb Wall Assembly**

1. FOR PROPER ALIGNMENT AND FUNCTION OF THE DUAL SWING DOOR, THE JAMB WALL MUST BE LEVEL, SQUARE AND PLANAR.

Verify that the Jamb Wall Assembly is level, planar, and aligned with the marks on the floor. Extend the Walls' leveling feet as required, but not more 1/2".

Then tighten the Enclosure Bracket screws.

2. Lower the Floor Anchor Brackets to the floor (if required) and then attach the brackets to the floor with appropriate fasteners for the site.

THE BOTTOM OF THE DOOR OPENING MUST MEASURE 48" ±1/16.

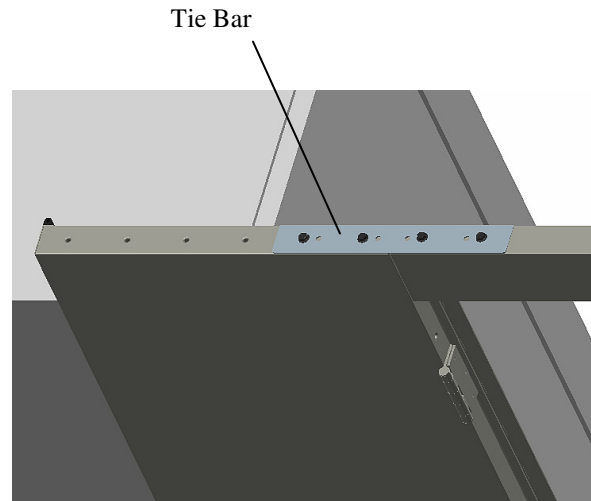

Failure to properly secure the Jamb Wall assembly to the electronic enclosures and to the floor will result in a potential tipping hazard which can cause serious injury.

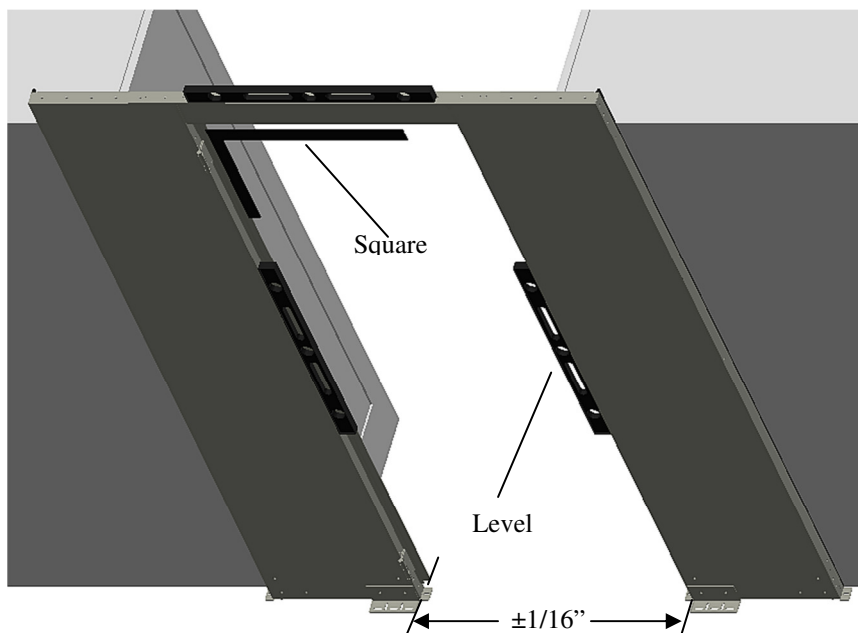

## Step 4: Install the Transom Cover

### Install the Transom Cover

Attach the Transom Cover to the Transom with (8) #10 x 3/8" Phillips Pan Head Self Threading Screws.

The pile gasket should be facing the door opening.

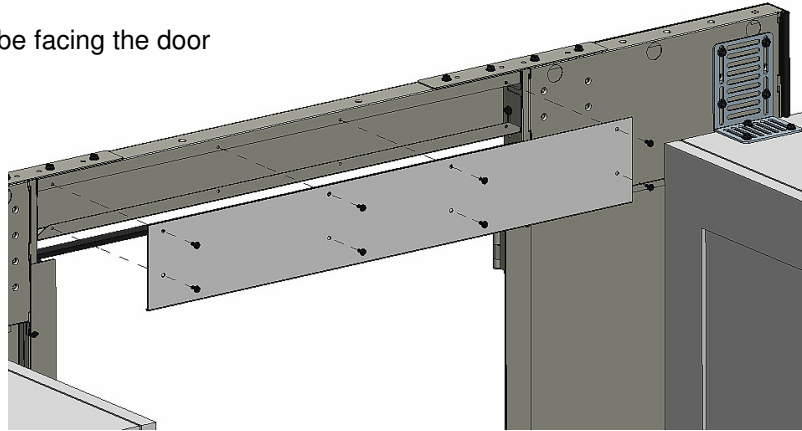

## Step 5: Install the Doors *(This is a two person job.)*

### Prepare the Doors

The left hand and right hand door panels are indicated with punched letters "L" and "R" on the back of the doors, near the top.

1. Remove and discard (2) Small Hole Plugs from the right side of the "L" door (as viewed from outside of the aisle).
2. Attach the Handle to the door with (2) #10-32 x 1-1/4" Phillips Head Machine Screws and (2) #10-32 Hex Keps Nuts.
3. Insert the Screw Cover into the Handle.
4. Insert (2) Large Hole Plugs into the screw access holes.
5. Repeat the procedure for the "R" door, creating a mirror image of the "L" door.

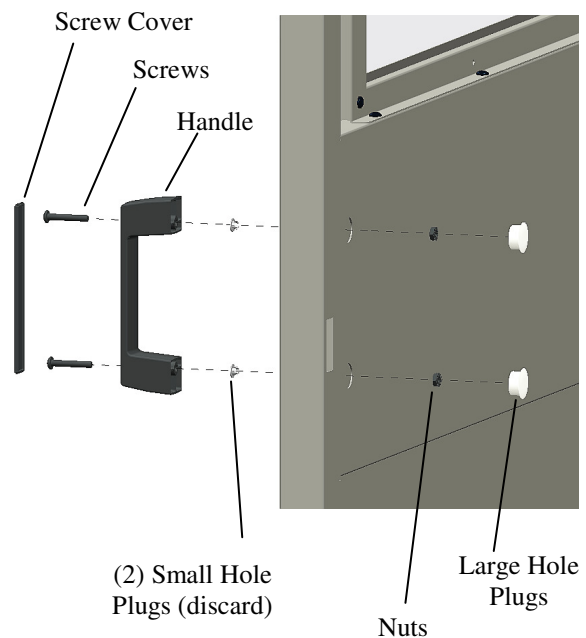

## Install the Doors

The screws that attach the door to the hinges **differ** from the screws that are used to attach the hinges to the Jamb Wall. The door screws are pre-installed into the door at the factory to ensure that they do not get intermixed with the wall screws.

1. Remove the (6) hinge screws from each door.
2. While one person positions the doors against the hinges, the other person can attach the doors to the hinges using the (12) hinge screws removed in step 1, (6) for each door.

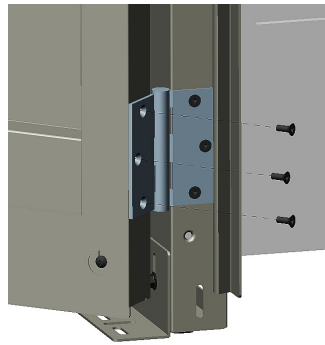

## Align the Doors

1. FOR PROPER ALIGNMENT AND FUNCTION OF THE DUAL SWING DOOR, THE JAMB WALL ASSEMBLY MUST BE LEVEL, SQUARE AND PLANAR.

2. Fully close the doors and examine the alignment of the doors with the Jamb Wall assembly.

When properly adjusted:

- a. The face surface of each door should align with the face of the Transom and with the face of the adjacent door, **and**
  - b. There should be a .20" (7/32") parallel gap between the tops of the doors and the Transom, **and**
  - c. There should be a .44" (7/16") parallel gap between the two doors.
3. If the doors do not simultaneously align with the face of the Transom and with each other, the Jamb Wall assembly is not planar. Adjust the top (or bottom) of one of the Jamb Walls either in or out, as required, to bring the doors into plane.
  4. If the gap between the tops of the doors and the Transom is not parallel, (and) or the center gap between the doors is not parallel, then the door opening is not square. Elevate (or lower) one of the Jambs Walls leveling feet to bring the top gap into parallel alignment (and) or reposition the Jamb walls to ensure a 48"  $\pm$ 1/16" door opening width at the floor.

### Align the Door Latches

If required, loosen and adjust the Male Door Latches laterally and vertically to ensure that they align with the Female Latches in the doors. When properly aligned, there should be very little resistance to engagement. Tighten the nuts to retain the adjustment.

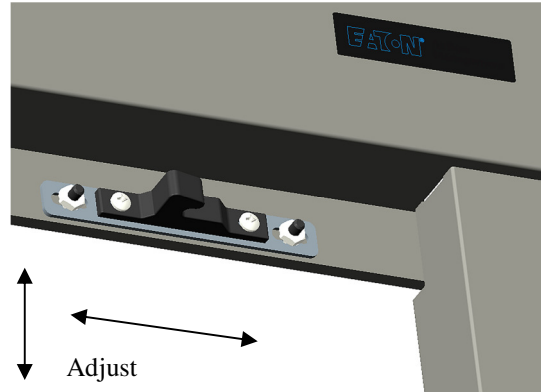

### Step 6: Adjust the Doors' Bottom Seals

*When properly adjusted, the doors' Bottom Seals should not hinder the free swing of the doors through their entire travel.*

Loosen the three screws that retain the Bottom Seal Plates into position. Slide the Bottom Seal Plates up or down as required, so that the edge of each Wiper Gasket maintains a minimum 1/16" gap to the floor through the entire swing of the doors.

Then tighten the screws to retain the adjustment.

Retention Screws

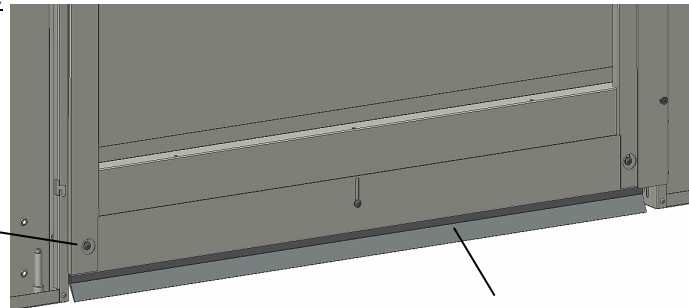

## Accessory Walls

Accessory Walls are available in 6", 9", 12" & 24" widths. Accessory Walls can be joined to the existing Jamb Wall to make a wider Jamb Wall Assembly.

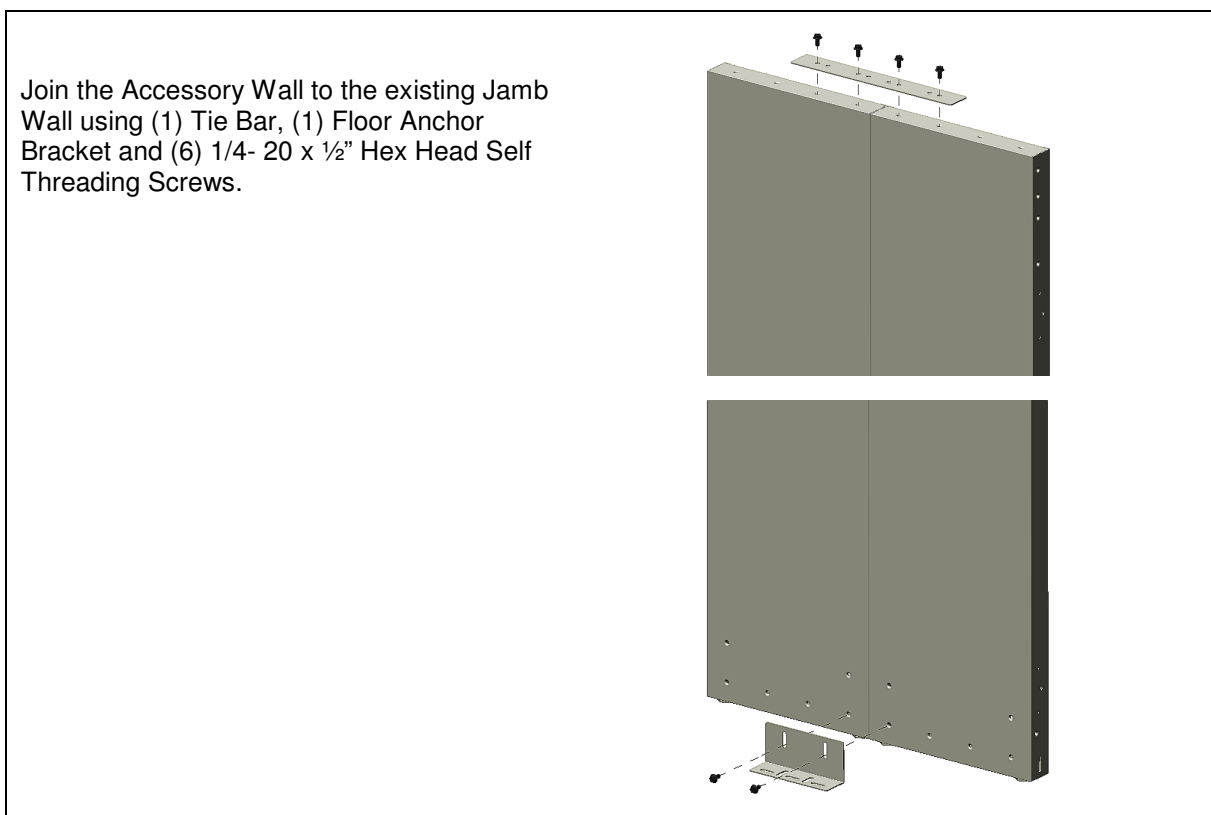

## Ceiling Hanger Attachment Bracket (part #SCCI)

If direct attachment to the electronic rack enclosures is not permitted, a Ceiling Hanger Attachment Bracket (part number SCCI) is available.

The Stud Plate that is included with the SCCI Bracket Kit is not required for this application. Attach the bracket directly to the back of the Jamb Wall with (2) 1/4- 20 x 1/2" Hex Head Self Threading Screws.

Attach your threaded rod to the "U" slots in the bracket with appropriate washers and nuts.

Additional lateral support is recommended, as shown, to prevent swaying of the Jamb Wall Assembly.

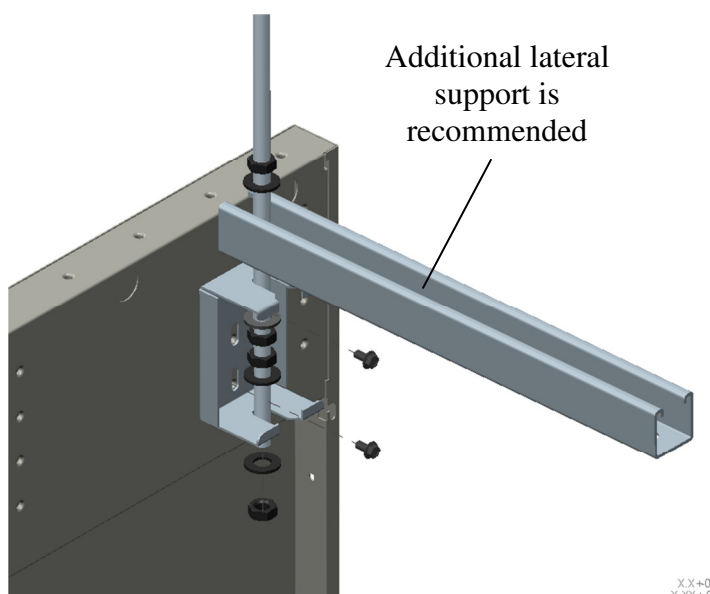

## Dual Swing End of Row Door Maintenance

This section describes how to care for your Eaton Dual Swing End of Row Door by performing regular maintenance. Regular maintenance will ensure trouble free operation of your door and efficient aisle containment.

### Routine Inspection and Cleaning as Needed

Conduct routine inspections on your door and perform necessary cleaning tasks as needed. Refer to the following table for routine tasks.

Inspect the free travel of the Dual Swing door. The doors should swing freely and easily latch closed, aligned with the Transom and the adjacent Jamb Walls. If not, adjust the Door Latch position, and the position of the Bottom Seals (see page 12).

<b>Task</b>	<b>Frequency</b>	<b>Tools and Supplies</b>
Clean Windows	As required	Clean with a non-solvent window cleaner approved for Lexan and Plexiglas.
Tighten all exposed screws and bolts	Annually	Refer to the <i>Dual Swing End of Row Door Fasteners</i> section on page 5 of this Installation Guide.
Adjust Door Bottom Seal	Annually, or as required	Refer to page 12 of this Installation Guide.
Adjust Door Latch	Annually, or as required	Refer to page 12 of this Installation Guide.





Information in this document is subject to change without notice. No part of this document may be reproduced or transmitted in any form or by any means, electronic or mechanical, for any purpose, without the express written consent of Eaton.

Eaton is a registered trademark of Eaton or its subsidiaries and affiliates. Phillips is a registered trademark of Phillips Screw Company. All other trademarks are the property of their respective owners.

**Eaton**  
Electrical Sector  
1000 Eaton Boulevard  
Cleveland, OH 44122 USA  
Eaton.com

© 2015 Eaton  
All Rights Reserved  
MN160017EN  
May 2015

**To contact an Eaton salesperson  
or local distributor, please visit  
[www.eaton.com/wrightline](http://www.eaton.com/wrightline) or  
call 800-225-7348.**



*Powering Business Worldwide*