

Installation Guide
Dual Cafe End of Row Door
Publication No. MN160016EN

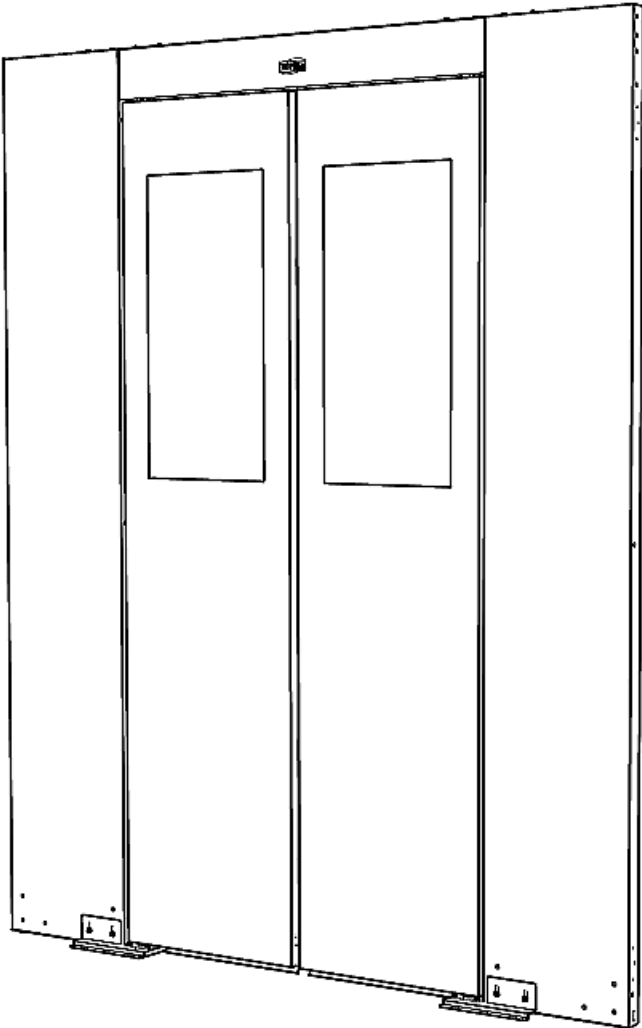

Table of Contents

About this Guide	2
Intended Audience	2
Technical Support	2
Sales Representative and Contact Information	2
Before You Begin	2
Tools Required.....	2
Installation Best Practices.....	3
Dual Cafe End of Row Door Components - Detailed Descriptions	4
Jamb Walls.....	4
Floor Anchor Brackets.....	4
Transom	4
Enclosure Brackets	4
Doors.....	5
Inner Transom Cover	5
Dual Cafe End of Row Door Fasteners	5
Installing an Eaton Dual Cafe End of Row Door.....	6
Step 1: Prepare the Site	6
Step 2: Erect and Secure the Jamb Walls.....	6,7,8
Step 3: Install and Align the Café Doors.....	9,10
Step 4: Adjust the doors' Perimeter Seals.....	10,11
Step 5: Adjust the Pivot Hinge Tension.....	11
Step 6: Install the Transom Cover.....	12
Accessories	12
Accessory Walls.....	12
Ceiling Hanger Support Bracket.....	13
Crash Plates.....	13
Dual Cafe End of Row Door Maintenance	14

About this Guide

This document contains general and detailed information about the installation, trouble shooting and care of Eaton's Dual Cafe End of Row Door product.

Intended Audience

This document is intended primarily for personnel responsible for installing and maintaining an Eaton Dual Cafe End of Row Door.

Technical Support

If you encounter any problems with this installation, send an email and detailed description of the problem as well as contact information to Technical Support at dc.support@eaton.com.

Sales Representative and Contact Information

Contact your Eaton Sales representative using one of the methods below:

Phone	Call us toll free at 800.225.7348 (US Only) or 508.852.4300
Mail	Eaton 160 Gold Star Boulevard Worcester, MA 01606
Email	InfoESWorcesterMA@Eaton.com
Web	Visit us at www.eaton.com/wrightline and click on "Contact Us." Simply complete and submit the form as directed on our website.

Before you Begin

Before installing an Eaton Dual Cafe End of Row Door, it is recommended that you familiarize yourself with the various door components described within this document. Also, it would benefit installers to review the following section titled *Installation Best Practices and Helpful Hints* on page 3 of this installation guide.



Tools Required

The following tools are required to complete the installation of an Eaton Dual Cafe End of Row Door:

- A tape measure
- A chalk line (if allowed in your data center)
- A spirit level
- A powered screw gun/driver
- A 3/8" hex socket driver bit
- A Phillips head driver bit

Installation Best Practices and Helpful Hints



This section contains an assortment of best practices and helpful hint topics that should be read before installing an Eaton Dual Café End of Row Door.



<p>More than a One Person Job</p>	<p>For reasons of safety and installation quality, it is highly recommended that two or more installers work together to complete the installation of an Eaton Dual Café End-of-Row Door.</p>
<p>Anchoring Dual Sliding End of Row Door Components to the Floor</p>	<hr/> <p> IMPORTANT! If there is additional hardware required to complete the installation of the Dual Café End of Row Door (floor, wall, and/or ceiling anchoring support), and the specified hardware is NOT itemized and included on the door quote, then the required hardware must be included and priced by the Installation Team on the installation quote.</p> <hr/> <p>The hardware required for anchoring Dual Café End-of-Row Door components to a facility floor depend upon the floor material. Anchoring hardware required for each facility is site specific and MUST BE SPECIFIED AND/OR APPROVED by facility management; preferably during the planning, design, and system ordering phase.</p> <p>When identifying anchoring hardware, take into consideration the type and length of anchoring screws used on a data center floor. The floor material may be steel, concrete, aluminum, or wood-core. The proper screw type and size should be used based on the floor material.</p> <hr/> <p> IMPORTANT! If prior to arrival, the installation team is not provided with details about the type of anchoring hardware required to conduct the installation, it is possible the team will arrive at the installation site without the necessary/proper anchoring hardware and the installation will be delayed until the proper anchoring hardware is either provided or acquired.</p> <hr/>
<p>Installation Accuracy</p>	<p>The Dual Café End of Row Door is a mechanical device that is shipped partially disassembled. As such the quality of door operation and reliability will depend on the accuracy of installation. Specifically, the smooth operating characteristics of the door rely on accurate measuring, leveling, squareness and alignment of the field installed components.</p>

Dual Cafe End of Row Door Components - Detailed Descriptions

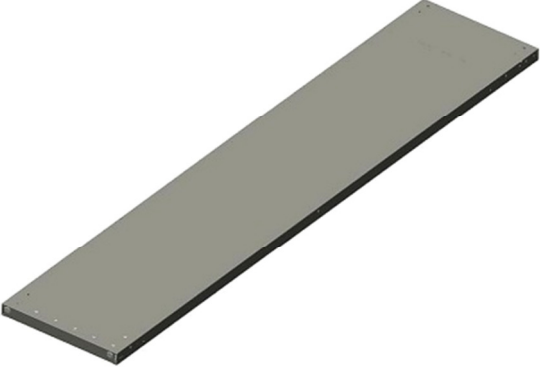
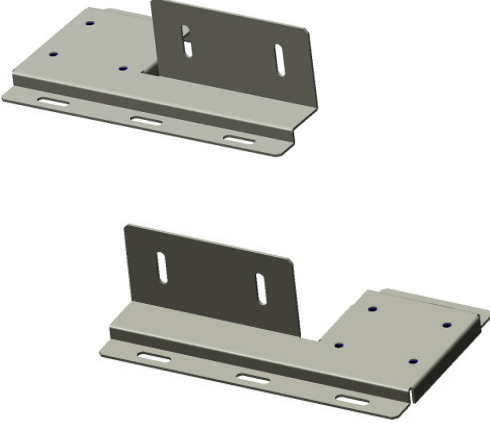

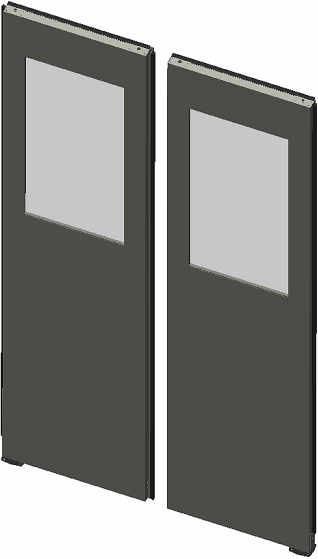

Dual Cafe End of Row Door Components

This section contains brief descriptions of the components used to construct an Eaton Dual Cafe End of Row Door. Detailed installation instructions start on page 6.

<p>Jamb Wall</p> <p>Jamb Walls are the vertical structures that define the sides of the door opening.</p>	
<p>Floor Anchor Brackets</p> <p>The Floor Anchor Brackets attach to the face of the Jamb Walls and provide a means to anchor the walls to the data center floor. The Floor Anchor Brackets also provide a mounting surface for the Café style Pivot Hinges.</p>	
<p>Transom</p> <p>The Transom is the horizontal structure that defines the top of the door opening.</p>	
<p>Enclosure Brackets</p> <p>The Enclosure Brackets provide adjustable attachment flanges that enable the Jamb Walls to be attached to the tops of the data center's electronic rack enclosures.</p>	

<p>Café Doors</p> <p>One left hand and one right hand Café Door assembly is provided.</p>	
<p>Inner Transom Cover</p> <p>The Transom Cover finishes off the inside of the Transom and provides a sealing surface for other aisle containment products.</p>	

Dual Cafe End of Row Door Fasteners

<p>1/4-20 Hex Head Self Threading Screw (Part #54348)</p> <p>A 3/8" hex socket bit is required to install this screw.</p>	
<p>#10 x 3/8" Phillips Pan Head Self Threading Screw (Part # 66714)</p> <p>A Phillips head bit is required to install this screw.</p>	
<p>#10-24 x 1/2" Phillips Pan Head Machine Screw (Part # 55617)</p> <p>A Phillips head bit is required to install this screw.</p>	
<p>#10 Washer (Part # 54225)</p>	

Installing an Eaton Dual Café End of Row Door

Step 1: Prepare the Site

1. Measure out 2" from each electronic rack and place marks on the floor.
2. Snap a chalk line on these two marks. This line represents the outer face of the Door Jamb Wall. (Note: if usage of a chalk line is not permitted in your data center, use another acceptable means to define this line.)
3. Mark two points on the line 42" apart to designate the desired position of the door opening width.

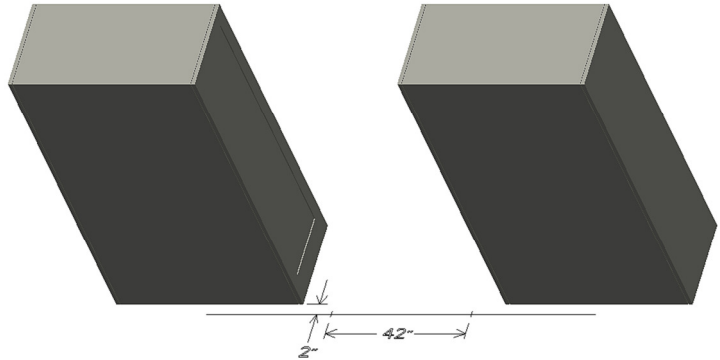

Step 2: Erect and Secure the Jamb Wall Assembly *(This is a two person job.)*

Apply Gasket to Jamb Walls

If it is necessary to seal the Jamb Walls to the electronic rack enclosures, apply the provided "D-bulb" gasket to the outer edges of each wall.

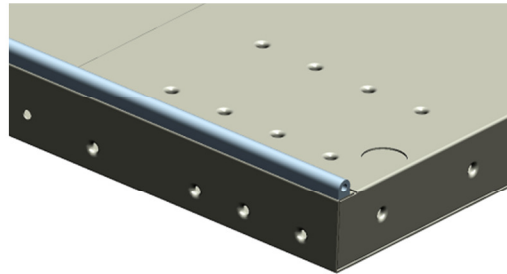

Right Hand Jamb Wall

Left Hand Jamb Wall

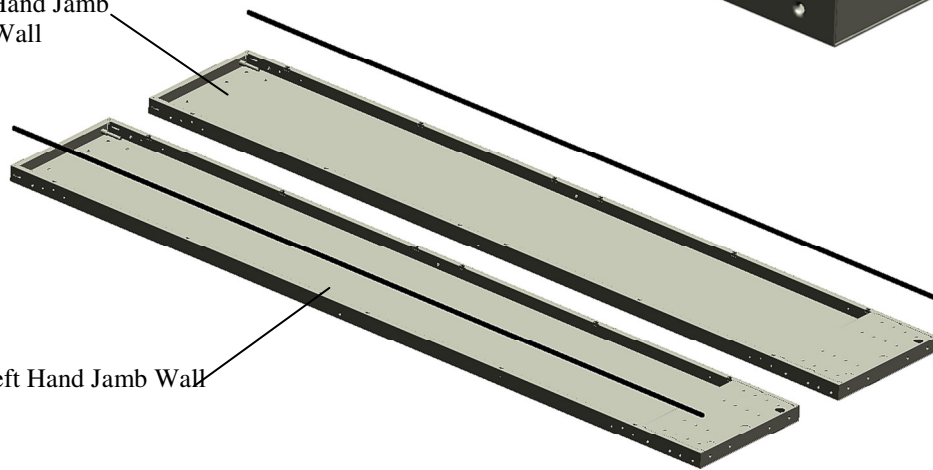

Erect the Jamb Wall Assembly

1. Ensure that the walls' leveling feet are fully retracted. Stand the Jamb Walls in place, aligned with the chalk line and the marks on the floor that define the door opening width.
2. Loosely attach the Jamb Walls to the tops of the electronic rack enclosures using (1) Enclosure Bracket for each wall. Attach the brackets to the walls in the most optimum position with (4) 1/4-20 x 1/2" Hex Head Self Threading Screws. Attach the brackets to the enclosures with appropriate fasteners. (*See note below.)
3. Install (1) 1/4-20 x 1/2" Hex Head Self Threading Screw into the top hole of each Jamb Wall. Leave the screws protruding about 1/8".
4. Engage the Transom onto the (2) top screws and then secure the bottom of the Transom to the Jamb Walls with (2) 1/4-20 x 1/2" Hex Head Self Threading Screws. Then tighten the top screws.

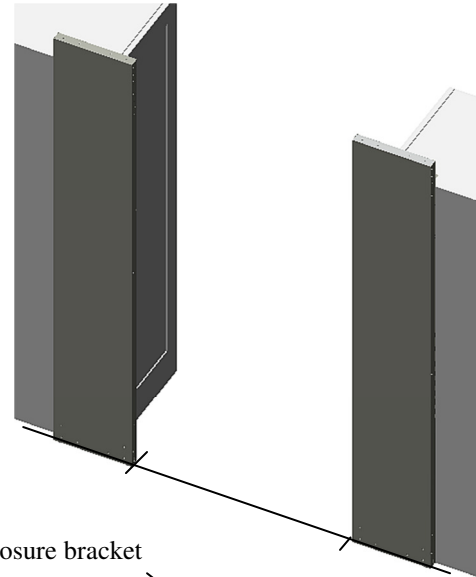

Enclosure bracket

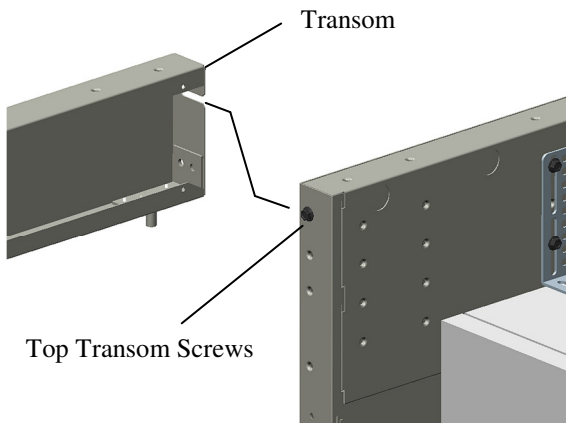
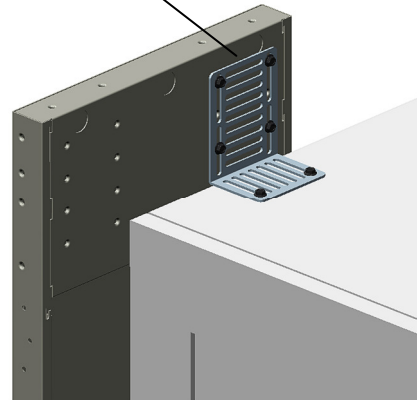

Transom

Top Transom Screws

Bottom Transom Screws

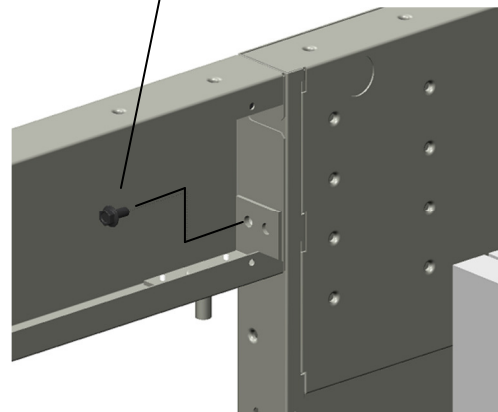

*Note: If direct attachment to the electronic rack enclosure is not permitted, a Ceiling Hanger Attachment Bracket (part number SCCI) is available. See page 13 for installation instructions.

(Erect the Jamb Wall Assembly - continued on next page)

5. Install a Tie Bar onto the top of the Jamb Wall Assembly at each Transom/Wall interface with (4) 1/4- 20 x 1/2" Hex Head Self Threading Screws.

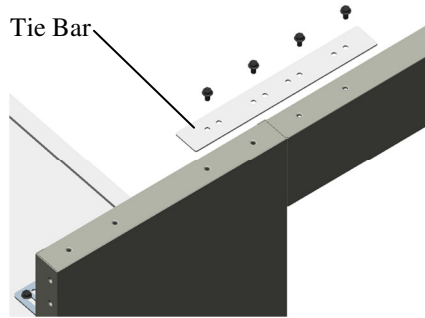

Level and Secure the Jamb Wall Assembly

1. Loosely assemble a left hand and right hand Floor Anchor Bracket to the Jamb Walls using (2) 1/4- 20 x 1/2" Hex Head Self Threading Screws for each bracket.
2. FOR PROPER ALIGNMENT AND FUNCTION OF THE CAFÉ DOORS, THE JAMB WALL MUST BE LEVEL, SQUARE AND PLANAR. Verify that the Jamb Wall assembly is accurately adjusted and aligned with the marks on the floor. THE BOTTOM OF THE DOOR OPENING MUST BE 42" ($\pm 1/16$ "). Extend the Walls' leveling feet as required, **but not more 3/8"**.

Extending the leveling feet more than 3/8" can result in the door(s) disengagement from the upper pivot pins, leading to potential serious injury. (See page 9.)

3. Lower the Floor Anchor Brackets to the floor (if required). Then tighten the Anchor Bracket and Enclosure Bracket screws. Now attach the Floor Anchor Brackets to the floor with appropriate fasteners for the site.

Failure to properly secure the Jamb Wall assembly to the electronic enclosures and to the floor will result in a potential tipping hazard which can cause serious injury.

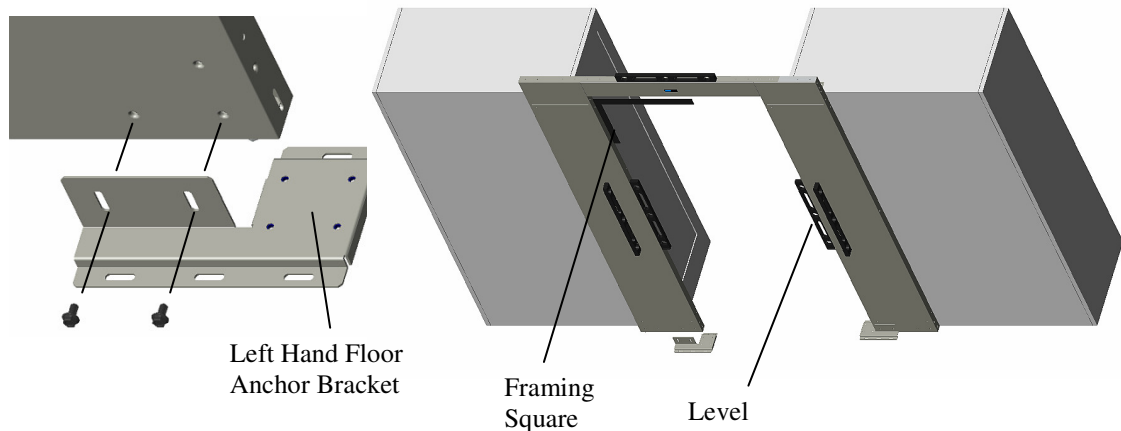

Step 3: Install and Align the Café Doors *(This is a two person job.)*

Install the Café Doors

1. Position the left hand Café door into the door opening, angling the door to insert the door's top Pivot Bushing onto the left hand Pivot Pin.
2. Continue to swing the left hand Café door into the door opening, seating the Pivot Hinge Plate onto the Floor Anchor Bracket.
3. Loosely attach the Pivot Hinge Plate to the Floor Anchor Bracket with (4) #10-24 x 1/2" Phillips Pan Head Machine Screws and (4) #10 Washers.
4. Repeat this procedure for the right hand Café Door.

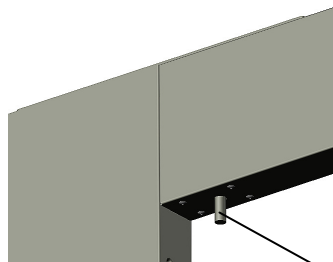
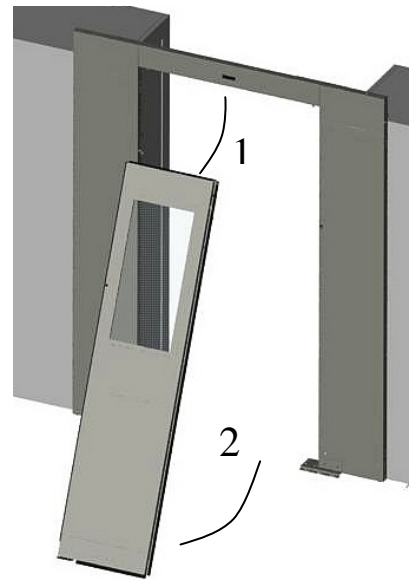

LH Pivot Pin

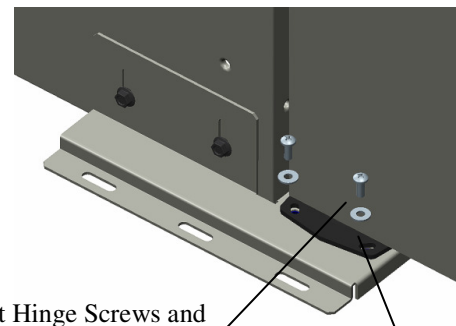

Pivot Hinge Screws and Washers (4); (2 sets are hidden behind the door.)

Pivot Hinge Plate

Align the Café Doors

1. The Café Doors' Pivot Hinge Plates have oval holes to allow for door alignment. Rotate the Pivot Hinge Plates as required to align the doors with each other, and then tighten the screws.
2. When the Pivot Hinges are properly adjusted:
 - a. The doors should align with each other, and
 - b. The doors should align with the face of the Transom, and
 - c. The gap between the top of the doors and the Transom should be evenly spaced along the entire width of the door opening.
3. If the doors will not simultaneously align with each other and with the face of the Transom, the Jamb Wall assembly is not planar. Adjust the top (or bottom) of one of the Jamb Walls either in or out, as required, to bring the doors into plane.
4. If the gap between the Transom and the top of the doors is not parallel, the door opening is not square. Elevate (or lower) one of the Jamb Walls leveling feet to bring the top gap into parallel alignment. See caution note on page 8 regarding leveler extension!

In some cases it may be necessary to use the shims provided to bring the top gap into alignment. See page 10 for additional instructions.

Install Door Shims (if required)

Refer to the last step on the previous page.

The parallel alignment of the gap between the tops of the doors and the Transom relies on the squareness of the Transom relative to the Jamb Walls (refer to the diagram on page 8).

However in some cases, even if the Transom is square to the walls, an uneven floor may cause one of the doors to sit lower than the other. Insert a maximum of (3) shims between the Pivot Hinge Plate and the Floor Anchor Bracket to elevate the lowest door.

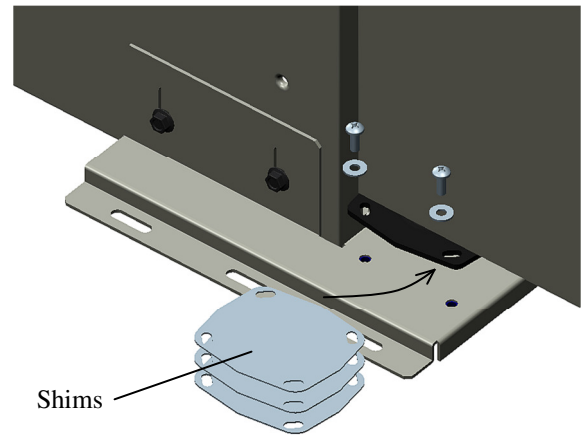

Step 4: Adjust the Door's Perimeter Seals

When properly adjusted, the doors' perimeter seals should not hinder the free swing or final closing position of the doors.

Adjust the Top Seals

1. Loosen the two screws that retain each Top Seal Plate into position.
2. Slide the Top Seal Plates up or down, as required, so that the pile gaskets barely touch the underside of the Transom. Then tighten the screws to retain the adjustment.

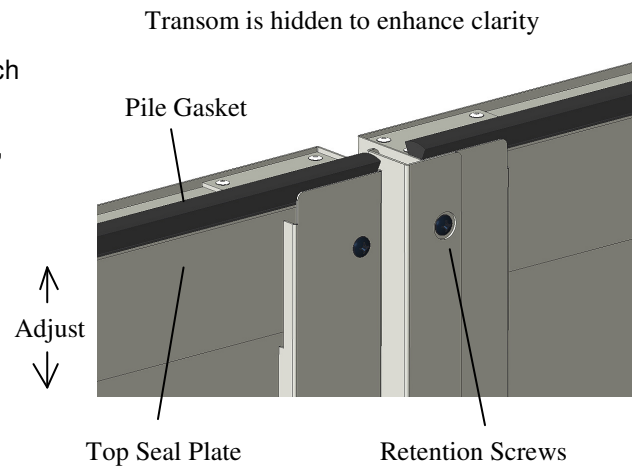

Adjust the Center Seal

1. Loosen the three screws that retain the Center Seal Plate into position.
2. Slide the Center Seal Plate laterally as required, so that the pile gasket barely touches the edge of the opposing door. Then tighten the screws to retain the adjustment.

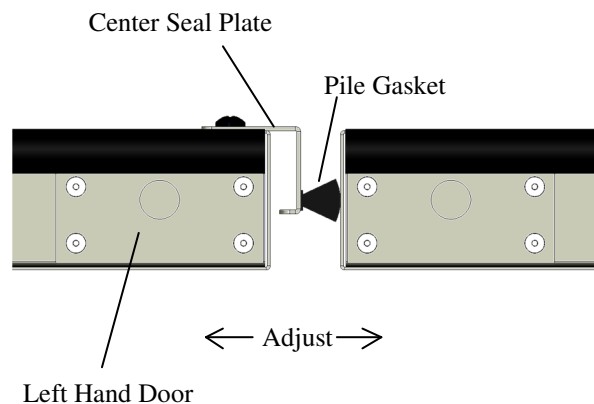

Adjust the Bottom Seals

3. Loosen the four screws that retain each Bottom Seal Plate into position.
4. Slide the Bottom Seal Plates up or down as required, so that the edges of the wiper gaskets maintain a minimum 1/16" gap to the floor through the entire swing of the doors. Then tighten the screws to retain the adjustment.

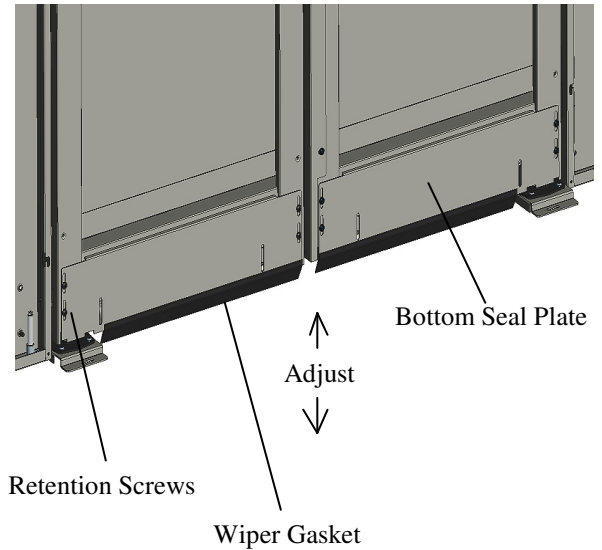

Step 5: Adjust the Pivot Hinge Tension

Adjust the tension of each Pivot Hinge by rotating the adjustment wheel on the hinge. Use the supplied pin to rotate the wheel. The wheel is accessed through the oval slot in the Bottom Seal Plate. (The hinges will normally be shipped with the hinges adjusted to the minimum tension.)

- a. Left Hand Door (as viewed from inside the aisle): To increase hinge tension, rotate the wheel as shown (pin rotating downward).
- b. Right Hand Door (as viewed from inside the aisle): To increase hinge tension, rotate the wheel as shown (pin rotating upward).

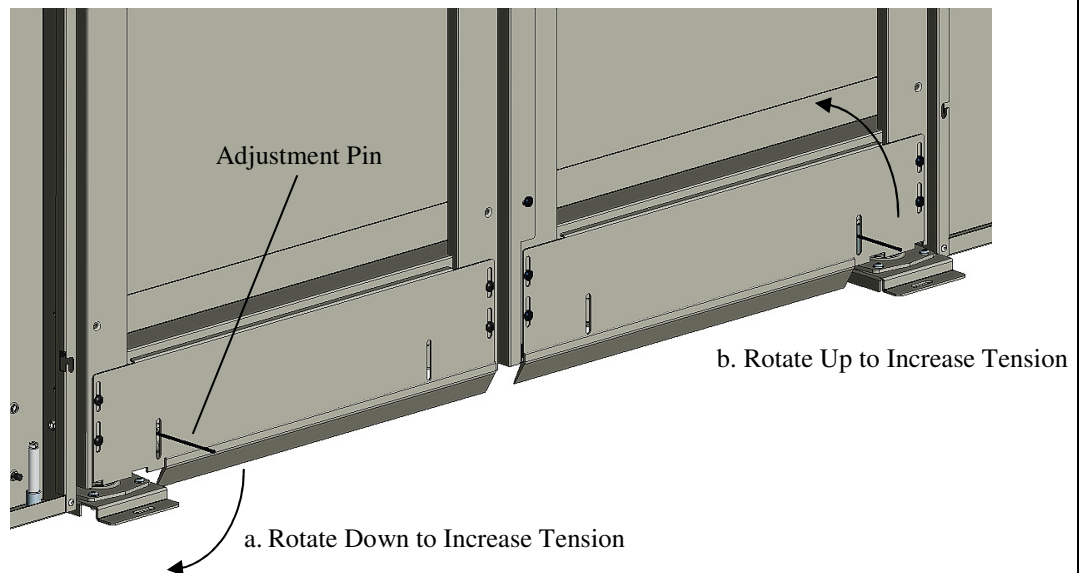

Step 6: Install the Inner Transom Cover

Attach the Inner Transom Cover to the Transom with (8) #10 x 3/8" Phillips Pan Head Self Threading Screws.

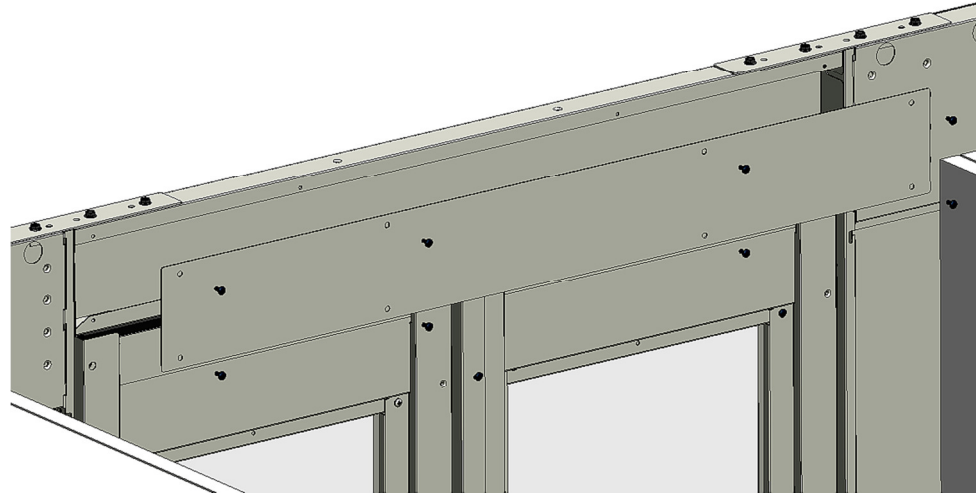

Accessory Walls

Accessory Walls are available in 6", 9", 12" & 24" widths. Accessory Walls can be joined to the existing Jamb Walls to make a wider Jamb Wall Assembly.

Join the Accessory Wall to the existing Jamb Wall using (1) Tie Bar, (1) Floor Anchor Bracket and (6) 1/4- 20 x 1/2" Hex Head Self Threading Screws.

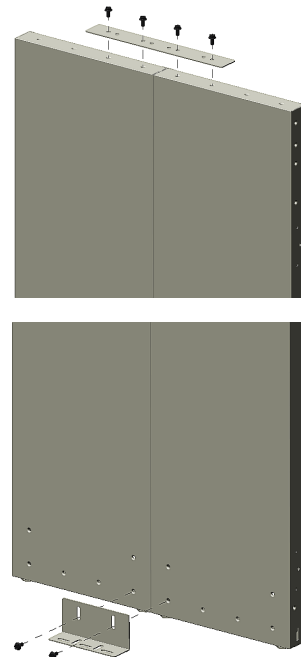

Ceiling Hanger Attachment Bracket (part #SCCI)

If direct attachment to the electronic rack enclosures is not permitted, a Ceiling Hanger Attachment Bracket (part number SCCI) is available.

The Stud Plate that is included with the SCCI Bracket Kit is not required for this application. Attach the bracket directly to the back of the Jamb Wall with (2) 1/4- 20 x 1/2" Hex Head Self Threading Screws.

Attach your threaded rod to the "U" slots in the bracket with appropriate washers and nuts.

Additional lateral support is recommended, as shown, to prevent swaying of the Jamb Wall Assembly.

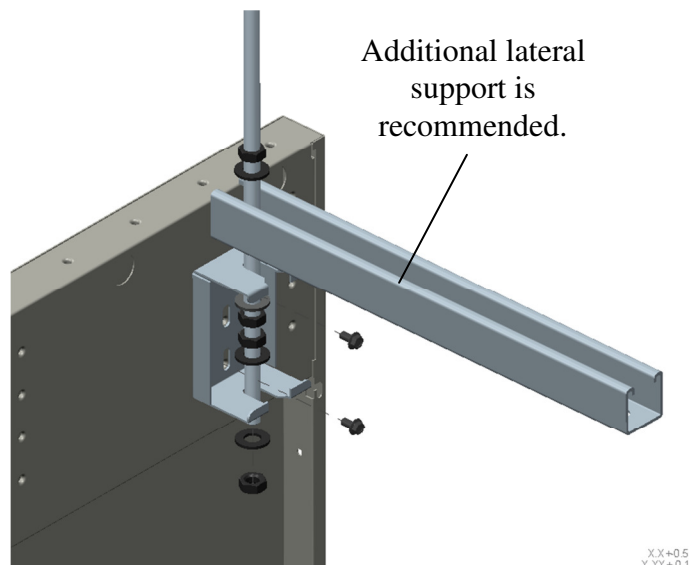

Crash Plates (part #EORDCRPLATE)

Attach the Crash Plates to the front and rear surfaces of the Café Doors. On the rear surface of the doors, the plates are attached to the center horizontal structure of the doors.

Before attaching the Crash Plates clean the surfaces of the doors with isopropyl alcohol. (If there is any oil based soil present, such as hand prints, pre-clean the doors with a commercially available degreaser before using the isopropyl alcohol.)

Lightly mark the location of the plates on the doors with a sharp pencil. The height of the plates can be varied somewhat, based on user preference. (38-1/2", as shown in the diagram, will center the plates on the door.) For visual appeal, the plates should be level.

Remove the liner paper from the double sided tape on the plates. Carefully align the plates with the pencil marks and press in place to secure.

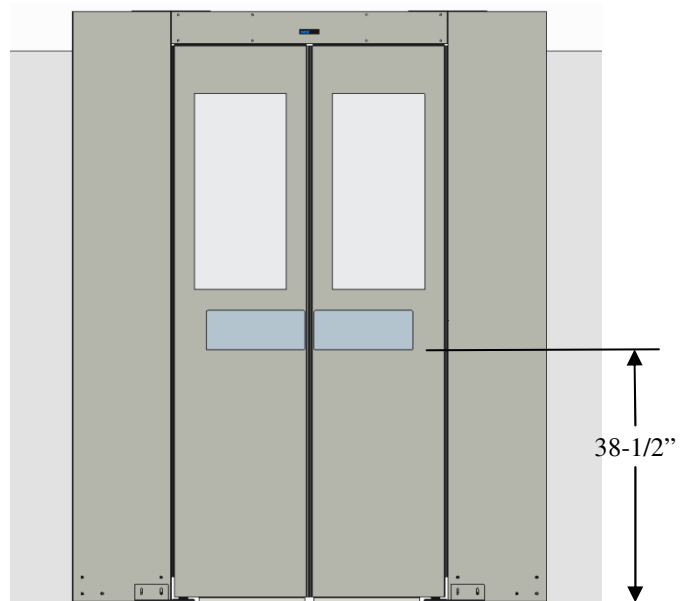

Dual Cafe End of Row Door Maintenance

This section describes how to care for your Eaton Dual Cafe End of Row Door by performing regular maintenance. Regular maintenance will ensure trouble free operation of your door and efficient aisle containment.

Routine Inspection and Cleaning As Needed

Conduct routine inspections on your door and perform necessary cleaning tasks as needed. Refer to the following table for routine tasks.

Inspect the free travel of the Cafe doors. The doors should swing freely and come to a gentle stop, aligned with one another and with the Transom. If not, adjust the doors' Pivot Hinge position and tension, and the position of the perimeter seals (see pages 9, 10 and 11).

Task	Frequency	Tools and Supplies
Clean Windows	As required	Clean with a non-solvent window cleaner approved for Lexan and Plexiglas.
Tighten all exposed screws and bolts	Annually	Refer to the <i>Dual Café End of Row Door Fasteners</i> section on page 5 of this Installation Guide.
Adjust Door Perimeter Seals	Annually, or as required	Refer to pages 10 and 11 of this Installation Guide.
Adjust Pivot Hinge Tension	Annually, or as required	Refer to page 11 of this Installation Guide.

Information in this document is subject to change without notice. No part of this document may be reproduced or transmitted in any form or by any means, electronic or mechanical, for any purpose, without the express written consent of Eaton.

Eaton is a registered trademark of Eaton or its subsidiaries and affiliates. Phillips is a registered trademark of Phillips Screw Company. All other trademarks are the property of their respective owners.

Eaton
Electrical Sector
1000 Eaton Boulevard
Cleveland, OH 44122 USA
Eaton.com

© 2015 Eaton
All Rights Reserved
MN160016EN
May 2015

**To contact an Eaton salesperson
or local distributor, please visit
www.eaton.com/wrightline or
call 800-225-7348.**



Powering Business Worldwide