

## BiWire Flexi

### BiWire Flexi Fire Panel

EFBW8ZONE-FLEXI / EFBW4ZONE-FLEXI / EFBW2ZONEFLEXI

### Installation Manual

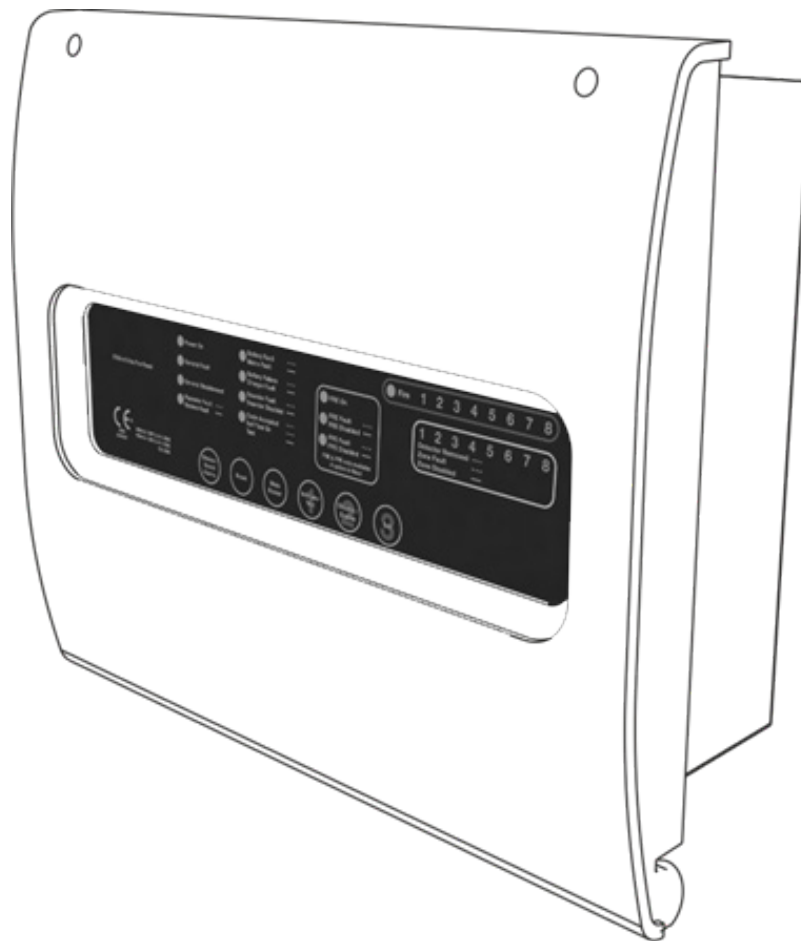

**EATON**

*Powering Business Worldwide*

**Contents**

- 1. INTRODUCTION.....4**
  - 1.1 Purpose ..... 4
- 2. THE BIWIRE FLEXI FIRE DETECTION & ALARM SYSTEM .....5**
  - 2.1 Control And Indication Equipment (CIE) ..... 6
  - 2.2 Power Supply Equipment (PSE) ..... 7
  - 2.3 EOLM-3..... 8
  - 2.4 EOLM-1..... 8
  - 2.5 EOLR..... 9
  - 2.6 System Wiring..... 9
  - 2.7 Status Indications..... 9
  - 2.8 Control Panel Inputs And Outputs ..... 10
    - Auxiliary Output..... 10
    - Class Change..... 10
    - Fire Relay..... 11
    - Fault Relay..... 11
    - Interlink Relay..... 11
    - Detector Zone Inputs..... 12
    - Conventional Sounder Circuits..... 12
    - Repeater I/O ..... 12
  - 2.7 Option Board (FRE/FPE/Zonal Relays) ..... 12
    - Fire Alarm Routing Equipment (FRE)..... 12
    - Fire Protection Equipment (FPE) ..... 12
    - Zonal Relay Contacts ..... 12
- 3. INSTALLATION INSTRUCTIONS.....13**
  - 3.1 Before You Begin..... 13
  - 3.2 Cabling Routing & Device Installation ..... 13
  - 3.3 Panel Installation ..... 14
    - Mounting the Panel ..... 14 - 15
    - Connecting the Mains Supply ..... 16
    - Connecting the Battery Supply ..... 17
    - Connecting the Zone Cables ..... 17
    - Connecting the Input/Output Cables ..... 18
    - Connecting a Repeater Panel ..... 18
    - Interlinking Two Panels ..... 18
  - 3.4 Option Board Installation..... 19
    - Connecting the FRE and FPE Outputs..... 20
    - Connecting the Zonal Outputs..... 20
  - 3.5 Panel Configuration..... 21
    - Silence Mode Disabled..... 21
    - Silence Mode Enabled ..... 21
  - 3.6 Detector Fitting ..... 21
  - 3.7 Installation Testing..... 21
    - Initial Power-up Check ..... 21
    - Zone Fault Detection Check ..... 22
    - Battery Fault Detection Check ..... 22
    - Zone Fire Detection Check ..... 22
    - Fire Outputs & Battery Check..... 23

<b>4. COMMISSIONING &amp; SYSTEM HANDOVER .....</b>	<b>24</b>
4.1 Commissioning .....	24
4.2 System Handover .....	24
<b>5. MAINTENANCE.....</b>	<b>25</b>
5.1 Daily Testing.....	25
5.2 Weekly Testing.....	25
5.3 Quarterly Testing.....	25
5.4 Yearly Testing.....	25
<b>6. OPERATING INSTRUCTIONS .....</b>	<b>26</b>
6.1 Multi-Function Buttons .....	26
6.2 Silence Fire Alarm Devices .....	26
6.3 Sound Fire Alarm Devices .....	26
6.4 Reset System .....	26
6.5 Mute Buzzer .....	27
6.6 Enable/Disable .....	27
6.7 Individual Zone Test .....	28
6.8 Lamp Test .....	28
6.9 Self-Test Mode .....	29
6.10 Walk Test Mode .....	29
<b>7. TECHNICAL SPECIFICATIONS .....</b>	<b>30</b>
7.1 Panel Specification .....	30
7.2 PSE Specification .....	31
7.3 EOLM-1 Specification .....	31
7.4 EOLM-3 Specification .....	31
7.5 Option Board Specification .....	32
7.6 Cable Specification .....	32
7.7 Compatible Devices .....	32
<b>8. MANUFACTURERS CONTACT DETAILS .....</b>	<b>35</b>

## 1. Introduction

### 1.1 Purpose

This manual is intended as a guide for the installation and commissioning of the BiWire Flexi 2/4/8 Zone Control panel. Content within this guide is for general application and does not specify the Fire Alarm System design and the guide assumes the reader already has attained competency with this type of system.

The installation of this system can only be carried out by a competent person with relevant current training and experience, with access to requisite tools, equipment and information (as stipulated by BS5839).

The design has been carried out in accordance with a quality management system, which incorporates a set of rules for the design of all elements of the CIE and PSE.

The components of the CIE and PSE have been selected for the intended purpose, and are expected to operate within their specification when the environmental conditions outside the cabinet of the CIE / PSE comply with class 3k5 of EN 60721-3-3:1995.

## 2. The BiWire Flexi Fire Detection & Alarm System

The BiWire Flexi fire alarm system is a highly adaptable and intelligent product designed with the simplicity of a conventional fire alarm system, enhanced to provide multi-function fire detection and condition indication capability. The Fire panel supports switchable zones that can be configured for BiWire Mode that has detectors, call points, sounders, and Visual Alarm Devices (VAD) combined on the zone, or Conventional Mode (Standard or Intrinsically Safe Mode) that only allows detectors and call points on the zone. BiWire Mode eliminates the requirement to have separate sounder circuits as with standard conventional systems, but the BiWire Flexi also comes with conventional sounder circuits to provide a purely conventional solution or a configurable retro-fit solution.

The BiWire Flexi fire alarm system is certified to EN54 part 2 and part 4 and is designed to meet the recommendations in BS5839.

The panels have the following optional features as standard:

- FIRE ALARM DEVICES: (EN54 part 2 clause 7.8)
- TEST CONDITION: (EN54 part 2 clause 10)
- Control of fire alarm routing equipment (EN54 part 2 clause 7.9.1)
- Output to fire protection equipment (EN54 part 2 clause 7.10.1)

The components of the BiWire Flexi Fire System are as follows:

- The Fire Panel is available to support 2, 4, and 8 Detection Zones. Each zone can be configured with up to 32 input devices (including detectors and manual call points) and 20 output devices connected via a single 2-core screened cable.
- The Fire Panel is available to support 4 conventional sounder circuits (see technical specification for loading characteristics) that can be used regardless of whether the zones are configured for BiWire or Conventional modes.
- The integrated EN54 part 4 compliant power supply charges and monitors two 12V 5Ah batteries. The power supply is capable of providing up to 24-hour standby depending on the system loading (further information on this can be found in the Technical information section of this document).
- When a zone is configured as BiWire mode, each zone must be terminated with an intelligent end of line monitoring module called the EOLM-3™. When a zone is configured for Conventional mode, each zone must be terminated with an EOLM-1 (for backward compatibility). Both EOLM modules need to be located with the last device on the zone.

- The Fire alarm system has an options interface board to provide outputs to Fire Protection Equipment (FPE), Fire Routing Equipment (FRE) and zonal relays. This interface and the relevant conformance requirements are further described within this guide.
- The BiWire Flexi panel is only compatible with BiWire Ultra range of devices for zones configured for BiWire mode, and is also compatible with the standard Eaton range of conventional devices on both conventional zones and sounder circuits. When a conventional zone is configured for Intrinsically Safe mode then intrinsically safe detectors can be fitted in conjunction with an isolation barrier (see technical specifications for more details).

## 2.1 Control and Indication Equipment (CIE)

The BiWire Flexi Fire Panel is designed as an Analogue non-addressable system. The panel enclosure is constructed from PC ABS components.

The front cover is hinged at the bottom and is secured at the top of the panel by two retaining screws. On the in-side of the panel a sliding PCB tray makes it easy to remove the tray without touching the PCB. The back box houses the PSE, the stand-by batteries and has 29 x 20mm cable access points. Terminal blocks are positioned to enable ease of connection.

The Fire Panel comes in 2, 4 & 8 Zone variants. Each of these variants will operate in the same manner only with a limited number of zones. Each zone can be independently configured with a variety of compatible BiWire Ultra devices or conventional devices (depending on the zone mode) up to a maximum load of 200mA per zone. BiWire and Conventional devices cannot be mixed together on a zone; each zone must either have a full complement of BiWire devices or conventional devices as per the zone mode setting. A maximum of 32 inputs devices (detectors and/or manual call points) and 20 output devices is possible as one BiWire configuration example; a loading calculator is available to assist with zone configuration.

The panel continuously monitors the state of each zone for Fire and Fault conditions which are only indicated on the affected zone. Once a Fire condition is detected on a zone then the panel turns on the Fire indicators for the zone in fire and triggers the fire alarm devices across all zones. All remaining zones will continue to monitor for secondary fires or fault conditions even though the sounders are operating.

The panel also continuously monitors the state of each conventional sounder circuit and will report any fault condition detected on the sounder fault LED.

The panel has multiple non-monitored outputs such as Auxiliary Output, Fire Relay, Fault Relay, and an Interlink Relay. These outputs are extended with the option board that provides additional monitored FFE and FPE outputs, and a non-monitored relay per zone circuit. The fire panel also has a monitored input called Class Change. Further information is contained within this guide.

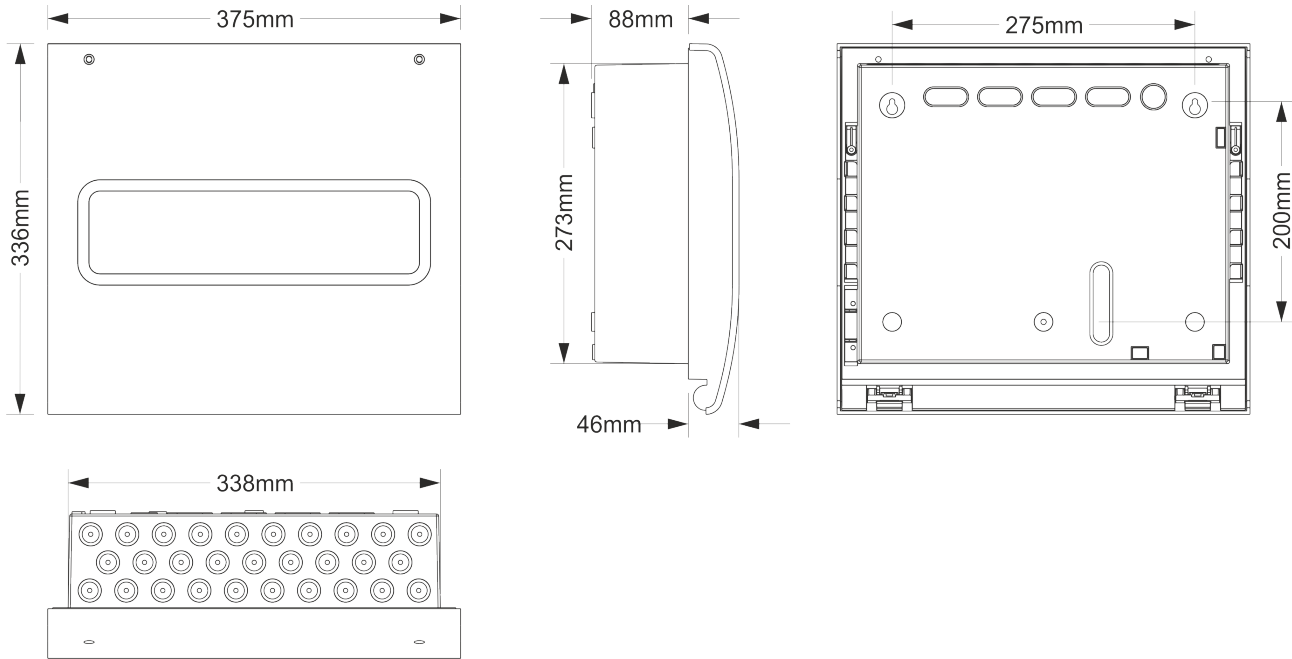

Figure 1: BiWire Flexi Fire Panel Dimensions

## 2.2 Power Supply Equipment (PSE)

The PSE has been specifically designed to operate the BiWire Flexi Fire Panel and may not be substituted for any other power source. The PSE is a Switch Mode Power Supply located within the Fire Panel cabinet as shown below. A dedicated 230V AC mains supply is required as the primary source; the supply is fused on the PCB by a 10 amp anti-surge fuse. In the event of mains failure the PSE will automatically switched over to the standby battery power source until the main power source is restored.

The PSE maintains the charge for the two 12V 5Ah sealed lead acid batteries in a fully charged state. On initial power up the batteries will charge over a 24 hour period. Dependent on the charge of the installed battery the system may initially shows a charger or battery fault.

The Supply should be clearly labelled 'FIRE ALARM: DO NOT SWITCH OFF' at all isolation points.

PSE faults originating from the following are indicated by the panel:

- The loss of either power source
- Failure of the charger circuit
- High internal resistance of the battery

The image shows the location of power supply.

(Further technical data for the PSE can be found in section 7.2).

Note that the charging circuit will be in its high impedance state (approximately 3V DC) if no batteries, faulty batteries, or only one battery is connected. The full 27V DC (nominal) charging voltage should be present if the correct batteries are connected.

In order to test for correct operation of the batteries, remove the mains 230V AC fuse and allow the batteries to settle from their charging voltage for approximately 5 minutes. The battery voltage should then be measured using an electronic test meter and a voltage greater than 24V DC should be seen.

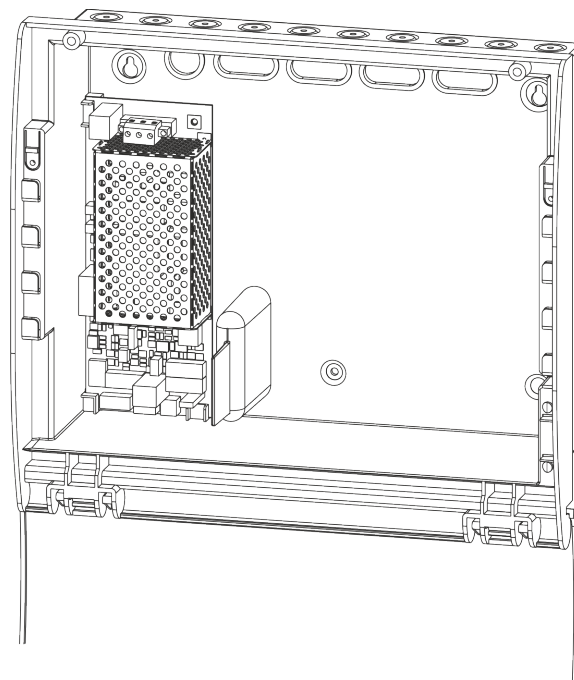

Figure 2: BiWire Flexi Power Supply Equipment

### BATTERY DISPOSAL INSTRUCTIONS

#### WARNING

CAUTION: RISK OF EXPLOSION IF BATTERY IS REPLACED BY AN INCORRECT TYPE

This product contains batteries and they must be disposed of in accordance with current waste disposal and pollution legislation and in particular The Environmental Protection Act 1990, Special Waste Regulation 1996. It is recommended that the following authorities are contacted before any attempt is made to dispose of batteries; Environment Agency Local office, Local Authority Environmental Health or Waste Handling department.

An improperly disposed battery can be harmful to the environment and human health.



# The BiWire Flexi Fire Detection & Alarm System

## 2.3 EOLM-3

Each Zone on the panel that is configured for BiWire mode must have the intelligent end of line module (EOLM-3™) fitted to continually monitor each zone for the presence of fault conditions such as detector head removal, open or short circuit and for end of line failures even when in a Fire condition.

For new installations, any Zone on the panel that is configured for Conventional mode can use the intelligent end of line module (EOLM-3™) to terminate the zone but the panel will be limited to only detecting the presence of open or short circuit conditions to make it backward compatible with the EOLM-1. All detector head removals will be seen as an open circuit condition.

The EOLM-3™ module can be placed into the base of the last manual call point or detector base.



Figure 3: BiWire Flexi EOLM-3 Module

## 2.4 EOLM-1

Each Zone on the panel that is configured for Standard Conventional mode must have the intelligent end of line module (EOLM-1™) fitted to continually monitor each zone for the presence of fault conditions such as detector head removal, open or short circuit and for end of line failures even when in a Fire condition.

The EOLM-1™ module can be placed into the base of the last manual call point or detector base.



Figure 4: BiWire Flexi EOLM-1 Module

---

**⚠ CAUTION**

---

RISK OF DAMAGE TO EOLM-3 IF CORRECT WIRING POLARITY IS NOT OBSERVED

## 2.5 EOLR

Each Zone on the panel that is configured for Intrinsically Safe Conventional mode must separate the intrinsically safe devices from the panel using the intrinsically safe barrier MTL5561. The last device on the zone must be terminated with a 5K1 End of Line Resistor to ensure proper fault and fire monitoring of the zone.

Any Sounder Circuit on the panel that is being used for Intrinsically Safe Sounders must separate the intrinsically safe alarm devices from the panel using the intrinsically Safe Barrier MTL7778ac. The last alarm device on the sounder output must be terminated with a 6K8 End of Line Resistor to ensure proper fault monitoring of the circuit.



## 2.6 System Wiring

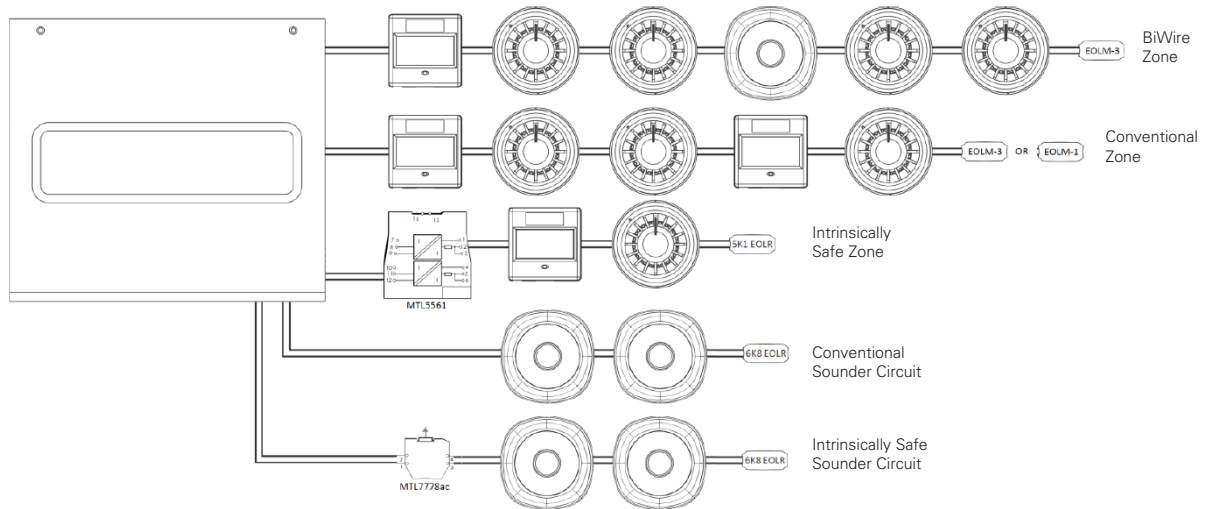

Figure 5: System Wiring Diagram

For zones configured in BiWire mode the zone can be wired for both BiWire detection (detectors and call points) and BiWire alarm (wall/base sounders, VADs and I/Os) devices terminated with an EOLM-3 embedded in the last device. Intrinsically safe and standard conventional detection and alarm devices cannot be wired onto a BiWire zone.

For zones configured in Conventional mode the zone is wired for Conventional detection (detectors and call points) devices only and must be terminated with an EOLM-1 or EOLM-3 embedded in the last device. Intrinsically safe conventional and BiWire detection and alarm devices cannot be wired onto a conventional zone.

For zones configured in Intrinsically Safe Conventional mode the zone is wired into the MTL5561 intrinsically safe barrier and all Intrinsically Safe Conventional detection (detectors and call points) devices are wired into the barrier with a 5K1 EOLR embedded in the last device. Standard conventional and BiWire detection and alarm devices cannot be wired onto an intrinsically safe conventional zone.

For sounder outputs used with standard conventional alarm (wall/base sounders, VADs and I/Os) devices the circuit must be terminated with 6K8 EOLR embedded in the last device. Intrinsically safe alarm devices cannot be mixed with standard conventional alarm devices as an intrinsically safe barrier must be used (see below). BiWire alarm devices cannot be wired to a conventional sounder output.

For sounder outputs used with Intrinsically Safe alarm devices the circuit must be wired into the MTL7778ac intrinsically safe barrier and all Intrinsically Safe Conventional alarm (wall/base sounders, VADs and I/Os) devices are wired into the barrier with a 6K8 EOLR embedded in the last device. Standard conventional alarm devices cannot be mixed with intrinsically safe alarm devices. BiWire alarm devices cannot be wired to a conventional sounder output.

For zones configured as Standard or Conventional mode the zone can be wired for detection (detectors and call points) devices terminated with an EOLM-1 and alarm (wall/ base sounders, VADs and I/Os) devices on separate circuits, as illustrated below.

## 2.7 Status Indications

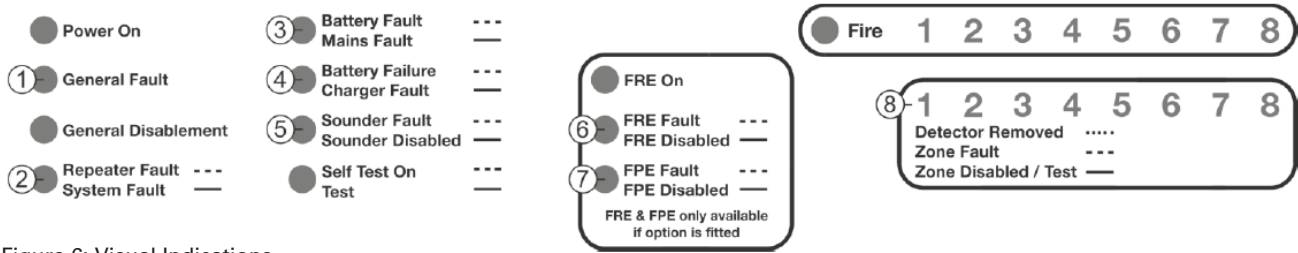

Figure 6: Visual Indications

### KEY

ON (—)	Indicator lit
OFF	Indicator unlit
SLOW (- - - -)	Indicator slow flashing, buzzer slow pulsing
FAST (-----)	Indicator fast flashing, buzzer fast pulsing
SILENT	Sounders off, buzzer off
CONT	Sounders on, buzzers continuous
	Any condition could be indicated

Condition	Visual Indications												Audiable Indications		Comments		
	Power ON	General Fault	General Disable	Repeater Fault / System fault	Battery Fault / Mains Fault	Battery Failure / Charger Fault	Sounder Fault / Sounder Disabled	Self Test On \ Test	FRE On	FRE Fault / FRE Disabled	FPE Fault \ FPE Disabled	General Fire	Zone Fire (1-8)	Detector Removed \ Zone Fault \ Zone Disabled		Fire Alarm Devices	Panel Buzzer
Normal Condition	ON	OFF	OFF	OFF	OFF	OFF	OFF	OFF	OFF	OFF	OFF	OFF	OFF	OFF	OFF	OFF	Normal condition and at access level 1
Access Level 2	ON															FAST	Access level 2 pass code accepted
Fire Condition	ON							ON			ON	ON			CONT	CONT	Only the zone in fire will have its zone fire indicator lit
System Fault	ON	ON		ON												SLOW	Severe fault condition with the panel
Repeater Fault	ON	ON		SLOW												SLOW	There is a problem with the link between panel and repeater
Battery Fault	ON	ON			SLOW											SLOW	No battery voltage or battery voltage too low
Mains Fault	ON	ON			ON											SLOW	Mains voltage has been lost
Battery Failure	ON	ON				SLOW										SLOW	Battery impedance fault
Charger Fault	ON	ON				ON										SLOW	Charger voltage fault
Sounder Fault	ON	ON					SLOW									SLOW	Short or Open circuit condition on the sounder circuit
FRE Fault	ON	ON							SLOW							SLOW	Short or Open circuit condition on the FRE
FPE Fault	ON	ON								SLOW						SLOW	Short or Open circuit condition on the FPE
Zone Fault	ON	ON											SLOW			SLOW	Short or Open circuit condition or head removal on the zone
Detector Removed	ON	ON												FAST		SLOW	BiWire Zones Only can detect when a Detector head has been removed
Sounder Disabled	ON		ON				ON										ALL fire alarm devices on ALL zones disabled
FRE Disabled	ON		ON						ON								FRE disabled
FPE Disabled	ON		ON							ON							FPE disabled
Zone Disabled	ON		ON											ON			Zone is disabled from fire detection
Individual Zone Test Active	ON							ON						ON	SLOW		An individual zone is in test mode and awaiting a fire activation

## 2.8 Control Panel Inputs and Outputs

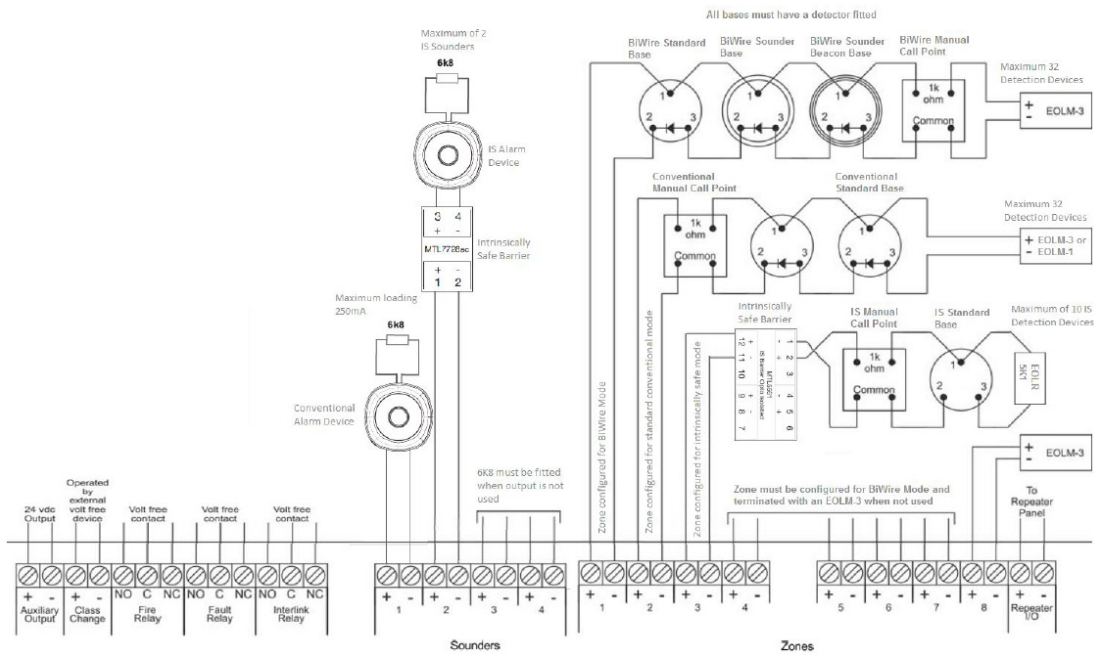

Figure 7: Panel Wiring Diagram

### Auxiliary Output

The Auxiliary Output is a 30V DC output provided at the panel to power ancillary equipment. The current consumed by this output must be considered when calculating battery standby times. The contacts are not monitored.

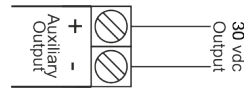

Figure 8: Auxiliary Output Terminal

### Class Change

The sounders can be operated by an external volt free contact. A short circuit at this terminal will activate non-latching sounders (no indication will show on the fire alarm panel). The sounders will automatically silence when the short circuit is removed. This is sometimes used for schools at class change times.

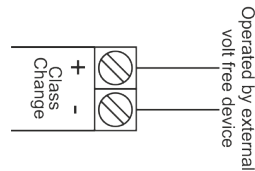

Figure 9: Class Change Input Terminal

### **⚠ WARNING**

NO VOLTAGE SHOULD BE APPLIED TO THIS INPUT

# The BiWire Flexi Fire Detection & Alarm System

## Fire Relay

The fire relay provides a set of fused volt free changeover contacts, which operate in the event of a fire condition, these contacts are not monitored. The fire relay can be used as Fire Alarm Routing Equipment or Fire Protection Equipment outputs.

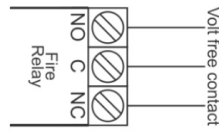

Figure 10: Fire Relay Terminals

## Fault Relay

The fault relay provides a set of fused volt free changeover contacts, which operate in the event of a fault condition, these contacts are not monitored. This relay has been configured to be in fail safe mode, so in the event of total power loss the relay contacts will be active.

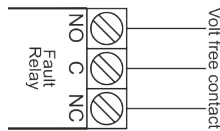

Figure 11: Fault Relay Terminals

Fault Relay reporting:

- Battery fault
- Mains fault
- Charger fault
- Impedance fault
- Zone faults:
  - Open circuit
  - Short circuit
  - Detector removal
- Sounder fault
- Repeater fault
- FRE fault
- FPE fault

## Interlink Relay

The Interlink Relay in conjunction with a non-latching zone can be used to link two BiWire Flexi fire panels together (Figure 12) or to link a BiWire Flexi to a BiWire Ultra panel. It is recommended to use a non-latching zone in the BiWire mode and fit the EOLM-3 at the interlink relay of each panel.

### WARNING

WHEN A ZONE IS BEING USED FOR INTERLINKING PANELS, NO OTHER DEVICES ARE PERMITTED ON THAT ZONE.

When an alarm is activated on one of the panels, the appropriate zone will indicate on the panel detecting fire and the interlink relay will activate. This in turn will activate the non-latching zone on the other panel and both panels will be in fire and all sounders on both panels will be activated.

To reset both panels, one of the panels would be manually soft reset, which would cause the non-latching zone on the other panel to reset as well. This would reset both panels.

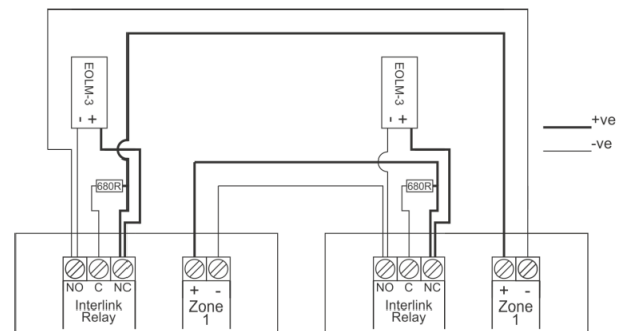

Figure 12: Interlink Connections

## Detector Zone Inputs

Each zone is configured by default to BiWire mode and is provided with an EOLM-3 fitted inside panel.

For zones that need to be in BiWire mode the EOLM-3 must be removed from the panel and fitted to the last device on each zone (Figure 7). Any unused BiWire zones must be terminated inside the panel by the EOLM-3 otherwise the zone will go into fault condition.

For zones that need to be in Standard Conventional mode then for new installs the EOLM-3 must be removed from the panel and fitted to the last device on each zone (Figure 7), for retro-fit installs that already has an EOLM-1 fitted at the end of the zone then the EOLM-3 needs to be removed from the panel and not used, for retro-fit installs without an EOLM-1 then the EOLM-3 must be removed from the panel and used to replace the termination in the last device on the zone. Any unused standard conventional zone must be terminated with either an EOLM-3 or EOLM-1.

For zones to be configured in Intrinsically Safe Conventional mode the EOLM-3 must be removed and replaced by a 5K1 resistor (not supplied) and fitted in the last device at the end of zone after the intrinsically safe barrier. Any unused intrinsically safe zone must be terminated by the 5K1 end-of-line resistor.

It is recommended that any zone that is not in use should remain in the factory default configuration of BiWire mode with the EOLM-3 fitted in the panel.

## Conventional Sounder Circuits

For 2 and 4 zone panels the following sounder circuit rules apply:

- All Zones in BiWire Mode = 2 Sounder Outputs Available
- Half Zones in BiWire and Half in Conventional Mode = 2 Sounder Outputs Available

For 8 zone panels the following sounder circuits apply:

- 8 BiWire Zones = 0 Sounder Outputs Available
- 1-4 Conventional Zones = 2 Sounder Outputs Available
- 5-8 Conventional Zones = 4 Sounder Outputs Available

Each sounder circuit must be terminated by a 6K8 resistor whether the alarm devices are standard or intrinsically safe in order for the panel to detect Short and Open circuit faults. Even if the conventional sounder circuits are not in use they must be terminated by the 6K8 resistors inside the panel.

## Repeater I/O

Each repeater has its own mains supply and standby battery. The repeater output is designed to connect to another panel configured as a repeater using the RS485 protocol. The repeater would follow the indication of the main Panel showing faults, fires and disablements (Figure 13).

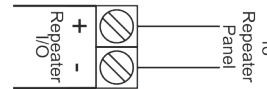

Figure 13: Repeater Panel Connection

## 2.9 Option Board (FRE/FPE/Zonal Relays)

The options board is an additional daughter card that provides outputs to Fire Protection Equipment (FPE), Fire Alarm Routing Equipment (FRE) and Zonal Relays.

### Fire Alarm Routing Equipment (FRE)

The FRE output is designed to activate during a fire event and is connected to phone diallers and/or Building Management Systems. When the FRE option board is fitted SW12-1 dip switch is set to Fitted. See figure 6. The output complies with EN54-2 clause:

- Outputs to fire alarm routing equipment (option with requirements)

### Fire Protection Equipment (FPE)

The FPE output is designed to activate during a fire event and when connected to external devices drive door release mechanisms, fire screens, sprinkler systems, and gas release systems. When FPE option board is fitted SW12-1 dip switch is set to Fitted. The output complies with EN54-2 clause:

- 7 .10.1 Outputs to fire protection equipment (Type A)

### Zonal Relay Contacts

Zonal relay contacts are volt free and do not provide any voltage. The relays are selectable to be either set to C/NO or C/NC. The zonal relays are designed to follow the fire condition of the associated zone circuit on the Main board.

### 3. Installation Instructions

This section of this guide explains in detail how the panel should be installed and configured to function properly. Please ensure you have fully understood the components of the system and how they operate before proceeding with this section. Take notice of the warnings and cautions as they are to prevent damage to your equipment.

#### 3.1 Before you begin

**CAUTION**

ENSURE ANTI-STATIC PRECAUTIONS ARE TAKEN WHEN HANDLING ELECTRONIC COMPONENTS OF THE SYSTEM. DO NOT USE EXCESSIVE FORCE WHEN TIGHTENING THE TERMINAL BLOCKS.

**NOTE**

WHEN INSTALLED THIS EQUIPMENT IS SUBJECT TO THE EMC DIRECTIVE 2004/108/EC. TO MAINTAIN EMC COMPLIANCE THE FIRE ALARM SYSTEM MUST BE INSTALLED AS INSTRUCTED. THE INSTALLER WILL BE RESPONSIBLE FOR ANY EMC PROBLEMS THAT MAY OCCUR EITHER TO THE FIRE ALARM SYSTEM OR TO ANY OTHER EQUIPMENT AFFECTED BY THE INSTALLATION IF THERE IS ANY DEVIATION FROM THIS GUIDE.

**NOTE**

INSTALLATION & MAINTENANCE MUST BE PERFORMED BY AN APPROPRIATELY QUALIFIED PERSON. THE EQUIPMENT CARRIES NO WARRANTY UNLESS THE SYSTEM HAS BEEN INSTALLED AND COMMISSIONED AND SUBSEQUENTLY MAINTAINED BY APPROPRIATELY QUALIFIED PERSONS OR ORGANISATIONS. DO NOT ATTEMPT TO INSTALL THIS EQUIPMENT UNTIL YOU HAVE FULLY READ AND UNDERSTOOD THE OPERATION AS DESCRIBED WITHIN THIS MANUAL, FAILURE TO DO SO MAY RESULT IN DAMAGE TO THE EQUIPMENT AND COULD INVALIDATE YOUR WARRANTY.

**WARNING**

WHEN INSTALLING THE BIWIRE FLEXI FIRE SYSTEM CARE SHOULD BE TAKEN TO ENSURE THAT THE INSTALLATION LOCATION DOES NOT SUBJECT THE PANEL TO ENVIRONMENTAL FACTOR IN EXCESS OF THE LIMITS OUTLINED IN THE TECHNICAL SPECIFICATION CONTAINED WITHIN THIS GUIDE.

#### 3.2 Cabling Routing & Device Installation

Route the fire rated cabling (for example FP200) between device locations in accordance with the zone map (and any other external equipment) and back to the panel location as indicated in the system design drawings. Each cable should be clearly labelled with their function, i.e. Zone 1 etc.

The bases of all fire devices should be fixed (refer to the installation guide supplied with each device) in the locations specified in the system design drawings.

The cabling to devices should be screwed into the terminals of the base or device (refer to the installation guide supplied with each device). The correct polarity should be observed along the cable routing.

The correct EOLM must be fitted at the end of each zone in (EOLM-3 for BiWire, EOLM-1 for Conventional).

The 6K8 resistor must be fitted at the end of each conventional sounder circuit.

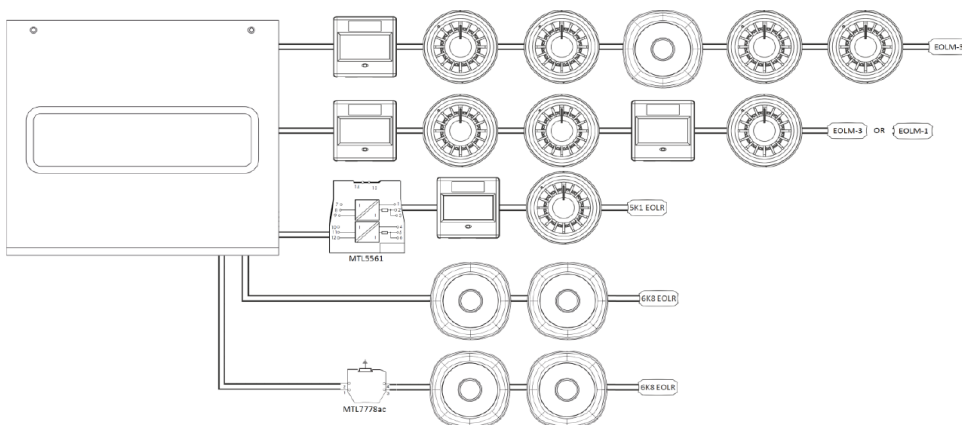

Figure 12: System Cabling

### 3.3 Panel Installation

---

**NOTE**

---

THE FOLLOWING INSTRUCTIONS MUST BE FOLLOWED WITH MAINS AND BATTERY SUPPLIES DISCONNECTED UNLESS OTHERWISE STATED.

---

**NOTE**

---

THE PANEL SHOULD BE INSTALLED IN A CLEAN, DRY, REASONABLY WELL VENTILATED PLACE, AND NOT IN DIRECT SUNLIGHT. TEMPERATURES IN EXCESS OF 40°C AND BELOW 5°C MAY CAUSE PROBLEMS, IF IN DOUBT CONSULT EATON FIRE SYSTEMS. THE PANEL SHOULD BE LOCATED AWAY FROM ANY POTENTIAL HAZARD, IN A POSITION WHERE IT IS READILY ACCESSIBLE TO AUTHORISED STAFF, AND THE FIRESERVICES, IDEALLY ON THE PERIMETER OF A BUILDING NEAR A PERMANENT ENTRANCE

#### Mounting the Panel

- To remove the front cover of the panel, unscrew the two retraining screws located at the top corners of the panel, see Figure 13.
- It is recommended to remove the PCB shelf and the PSE from the back box before drilling the holes.
- To remove the PCB shelf push the clips down (1), then push the shelf towards the top of the back box and then lift forwards (2), see Figure 14.
- To remove the PSE PCB from the back box unplug the cables from the main board as shown in Figure 15, then simply remove the screw and push the PCB up, to the right and forwards as shown in Figure 16.

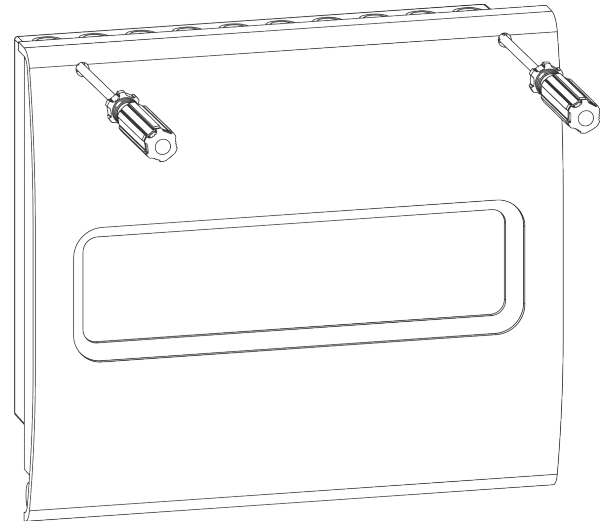

Figure 13: Removing the Front Cover

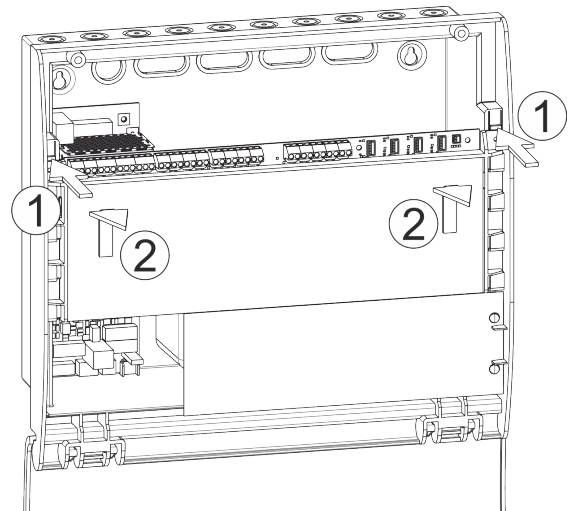

Figure 14: Removing the PCB Shelf

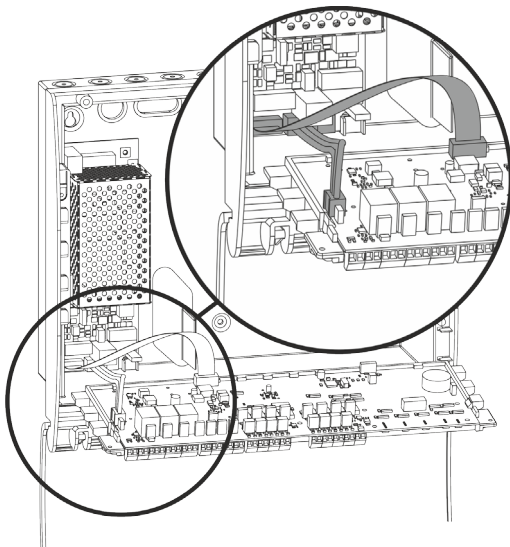

Figure 15: Disconnecting the PSE

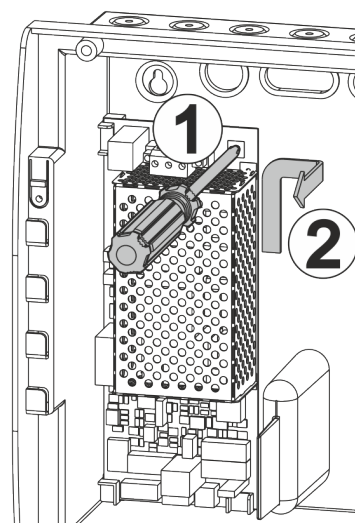

Figure 16: Removing the PSE

## Installation Instructions

- Once the cable entry holes have been cut then fit the cable glands to the back box.
- If the panel is being flush mounted, then insert the panel into the recess feeding the cables through the rear cable entry points.
- If the panel is being wall mounted then cut out the required number of cable entry holes in the back using a 20mm hole saw with pilot drill bit as shown in Figure 19. Fit the glands to the back box and pull through the required cables.

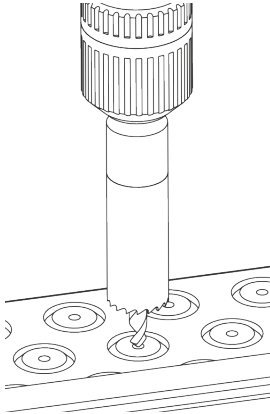

Figure 17: Cutting Cable Entry Holes

- Using the mounting holes in the back box, drill holes into the wall and insert wall plugs and secure the panel to the wall as shown in Figure 17. Ensure any dust is cleaned from the back box.
- Secure the PSE PCB back into the back box by following the reverse instructions in Figure 16.
- Fit the PCB shelf and cables by following the reverse instructions in Figure 14 and Figure 15.
- Fit the door back onto the back box by following the reverse instructions in Figure 13

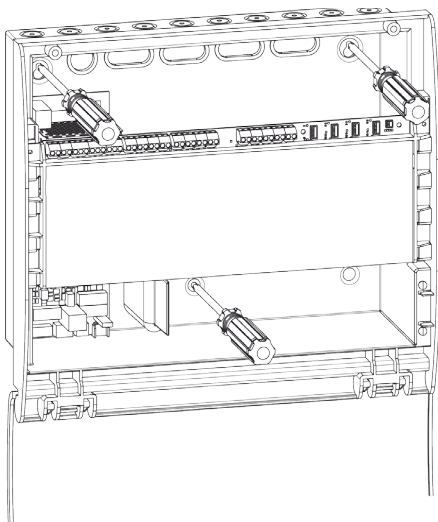

Figure 18: Securing the Panel to the Wall



## Connecting the Mains Supply

The mains supply should be exclusive to the fire alarm as detailed in BS5839. A plug and socket is not satisfactory. We recommend that a switched double pole fused spur unit is used for the sole use of the fire alarm system and should be clearly marked with:

### FIRE ALARM DO NOT SWITCH OFF

Before connecting the fused spur to the PSE, slide the ferrite core (supplied with the panel) over the cable as shown in Figure 19.

Connect the fused spur to the input marked MAINS on the PSE, observing correct wiring regulations (see Figure 16).

---

**NOTE**

---

OBEY VOLT DROP LIMITATION WHEN SIZING CABLES.

---

**NOTE**

---

USE ONLY APPROVED CABLE TYPES.

---

**NOTE**

---

DO NOT TIGHTEN TERMINAL CONNECTOR SCREWS TOO TIGHT.

---

**NOTE**

---

KEEP POLARITY THROUGHOUT. NON COLOURED CONDUCTORS SHOULD BE PERMANENTLY MARKED.

## Connecting the Battery Supply

A Battery cover is supplied to prevent accidental contact with the battery terminals and gives additional useful information. The battery cover can be moved out of the way as indicated in Figure 20.

Connect the spade connectors of the two wire battery cable and the single wire battery cable as illustrated in Figure 19.

Do not connect the plastic socket end of the battery cable to the PSE until all installation actions in this guide have been completed and the system is ready for testing.

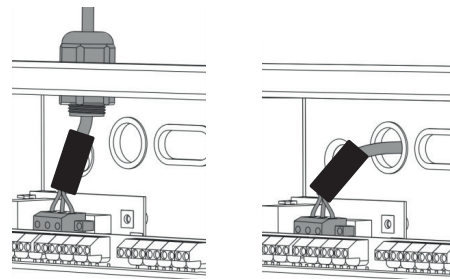
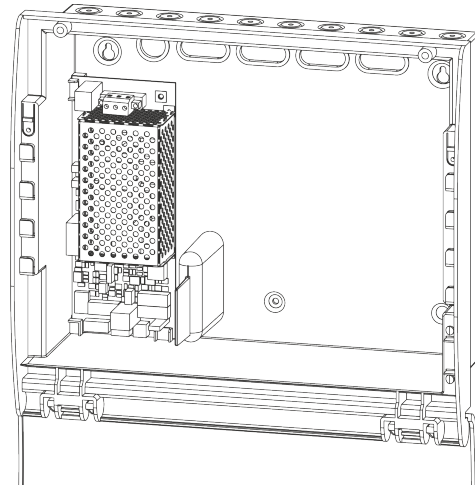

Figure 19: Mains Supply Connection to PSE

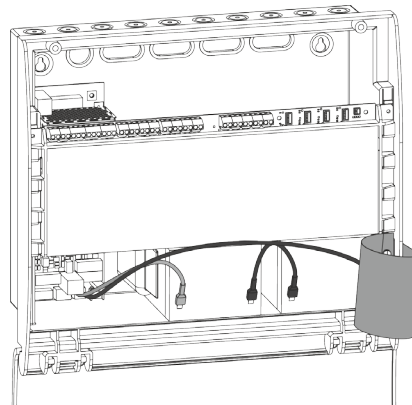
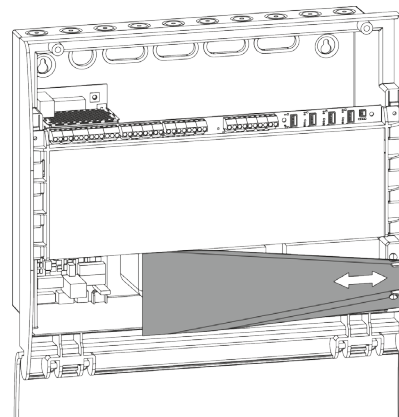

Figure 20: Battery Cover Removal

### Battery Connections

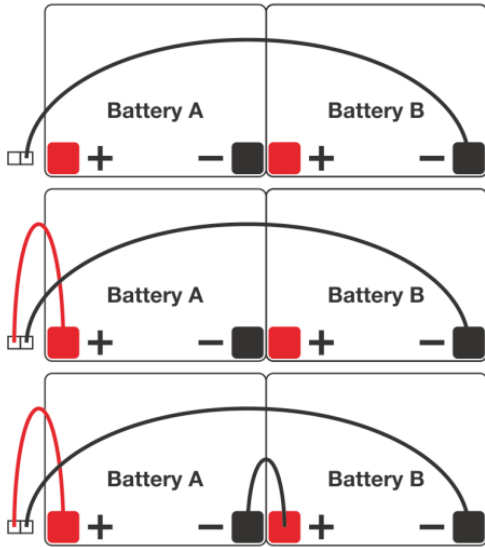

Figure 21: Battery Connection

#### Battery Connections:-

1. Connect the **BLACK** battery wire to the **BLACK (-)** battery terminal of battery **B**
2. Connect the **RED** battery wire to the **RED (+)** battery terminal of battery **A**
3. Connect the link cable between the two remaining terminals

### Connecting the Zone Cables

Connect the cables (clearly labelled with the zone numbers) to the appropriate zone +/- terminals, observing the correct polarity (see Figure 21).

If any of the zones are not used then the EOLM-3 must remain fitted to the terminals of that zone to ensure the system remains fault free.

---

**⚠ CAUTION**

---

DO NOT USE A HIGH VOLTAGE INSULATION TESTER

---

**⚠ NOTE**

---

IT IS IMPORTANT THAT ZONE CABLING IS CONNECTED TO THE CORRECT ZONE INPUT OTHERWISE ANY FIRE OR FAULT INDICATION ON THE PANEL WILL NOT MATCH THE ZONE MAP OF THE SITE, AND WILL NOT BE COMPLIANT TO BS5839.

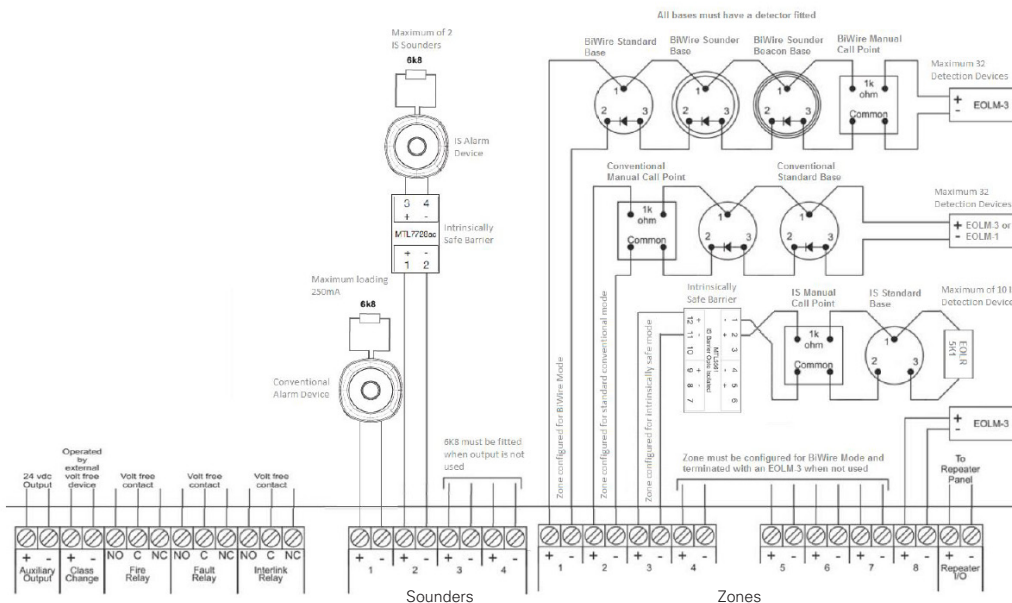

Figure 22: Panel Wiring Diagram

### Connecting the Input/Output Cables

Connect the cables (clearly labelled with the external equipment reference) to the appropriate input or output terminals, observing the correct polarity where applicable.

**CAUTION**

MAKE SURE TO FOLLOW THE INSTALLATION GUIDES OF ANY EXTERNAL EQUIPMENT AND CHECK THE CORRECT WIRING POLARITY AND THAT THE EQUIPMENT IS COMPATIBLE WITH THE BIWIRE FLEXI PANEL BEFORE POWERING UP THE SYSTEM.

### Connecting a Repeater Panel

Connect the cables from the repeater panel to the Repeater terminals on the main board of the fire alarm panel, observing the correct polarity (see Figure 22).

To enable the repeater output switch 2 of SW12 on the panel main board must be changed to the "Repeater Output On" setting (see Figure 23).

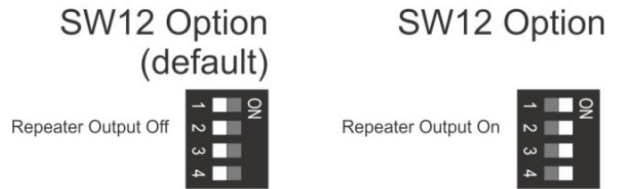

Figure 23: Repeater Out Setting

### Interlinking Two Panels

Wire the two panels together as shown in Figure 26.

The EOLM-3 must be fitted for the zone circuits on both panels to be monitored for fault conditions.

The 680ohm resistor must be fitted so that the zone input will detect the fire condition and activate its fire alarm devices.

In order for the Interlink to operate correctly the zone inputs on both panels being used for interlinking must be set to unlatched, therefore the associated switch on SW4 must be set to the "Unlatched Zone x" setting (see Figure 25).

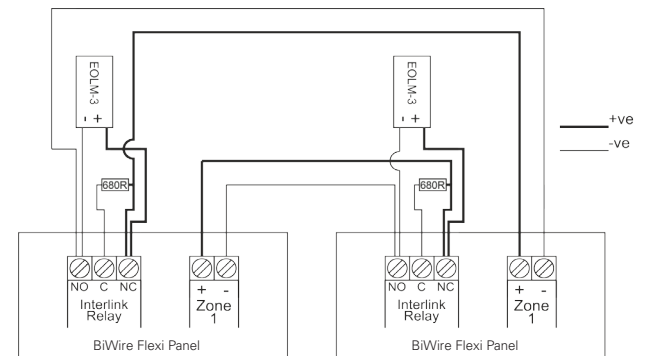

Figure 24: Interlink Wiring Diagram

**NOTE**

NO OTHER DEVICES ARE TO BE CONNECTED TO A ZONE CONFIGURED FOR INTERLINKING.

**WARNING**

THE UNLATCHING SETTING IS NOT TO BE USED WITH DETECTION ZONES AS THIS WILL MAKE THE PANEL NON-COMPLIANT.

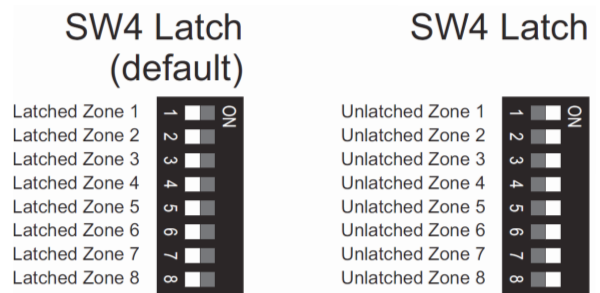

Figure 25: Interlink Settings

### 3.4 Option Board

#### Connecting the FRE and FPE Outputs

Connect the cabling from the fire alarm routing equipment and fire protection equipment to the relevant terminals on the option board.

As these outputs are monitored for short circuit and open circuit faults conditions, the 6K8 resistor supplied should be installed at the external equipment and not at the option board terminals.

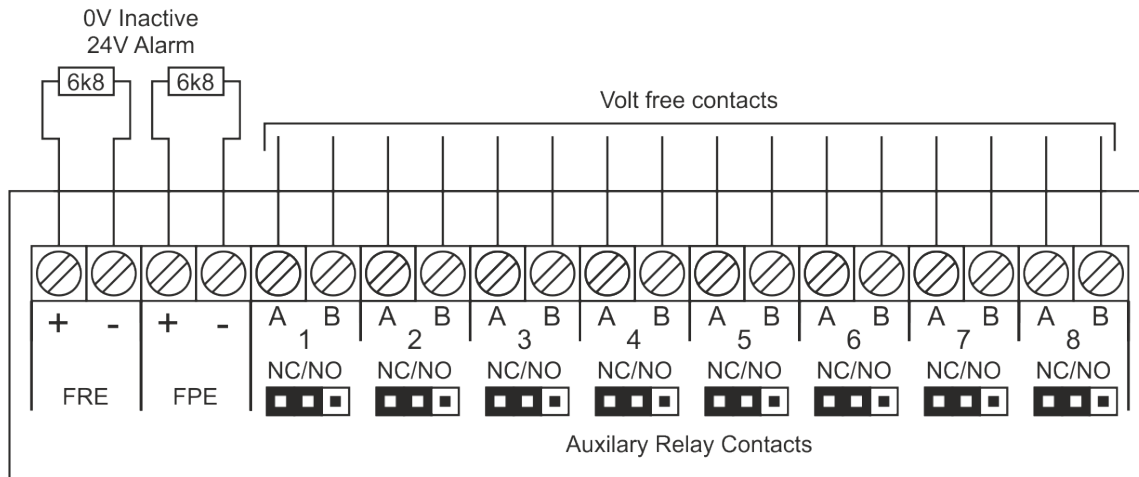

Figure 26: Option Board Wiring Diagram

**NOTE**

IF EITHER THE FRE OR FPE IS NOT BEING USED THEN THE 6K8 RESISTOR SHOULD BE FITTED AT THE APPROPRIATE TERMINAL ON THE OPTION BOARD. THIS PREVENTS ERRONEOUS FAULTS CONDITIONS BEING DISPLAYED ON THE PANEL.

#### Connecting the Zonal Outputs

Connect the cabling from the external equipment to the relevant zone terminals on the option board.

These outputs are not monitored so there is no need for a 6K8 termination resistor.

Change the jumpers on the zonal relays to get them to operate in either normally open or normally closed during a fire alarm condition.

### 3.5 Panel Configuration

#### Silence Mode Disabled

With switch 3 of SW12 on the panel main board set to "Silence Mode Disabled" the panel will re-sound all fire alarm devices after the panel has been silenced with any new fire conditions detected.

#### Silence Mode Enabled

With switch 3 of SW12 on the panel main board set to "Silence Mode Enabled" the panel will NOT re-sound the fire alarm devices after the panel has been silenced regardless of any new fire conditions detected.

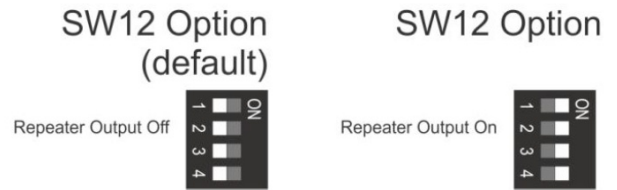

Figure 27: Silence Mode Setting

### 3.6 Zone Configuration

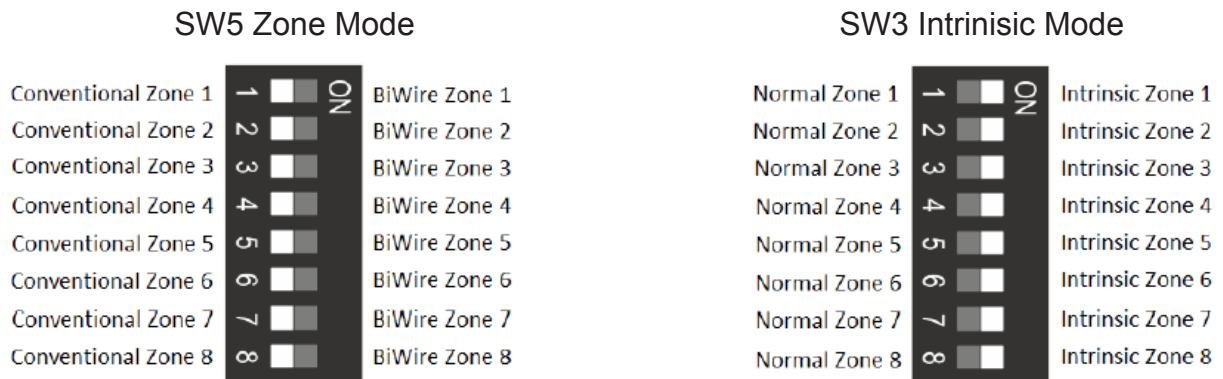

Figure 28: Zone Mode Setting

Zone #	BiWire Mode	Standard Conventional	IS Conventional
1	SW3.1 = N/A	SW3.1 = OFF	SW3.1 = ON
	SW5.1 = ON	SW5.1 = OFF	SW5.1 = OFF
2	SW3.2 = N/A	SW3.2 = OFF	SW3.2 = ON
	SW5.2 = ON	SW5.2 = OFF	SW5.2 = OFF
3	SW3.3 = N/A	SW3.3 = OFF	SW3.3 = ON
	SW5.3 = ON	SW5.3 = OFF	SW5.3 = OFF
4	SW3.4 = N/A	SW3.4 = OFF	SW3.4 = ON
	SW5.4 = ON	SW5.4 = OFF	SW5.4 = OFF
5	SW3.5 = N/A	SW3.5 = OFF	SW3.5 = ON
	SW5.5 = ON	SW5.5 = OFF	SW5.5 = OFF
6	SW3.6 = N/A	SW3.6 = OFF	SW3.6 = ON
	SW5.6 = ON	SW5.6 = OFF	SW5.6 = OFF
7	SW3.7 = N/A	SW3.7 = OFF	SW3.7 = ON
	SW5.7 = ON	SW5.7 = OFF	SW5.7 = OFF
8	SW3.8 = N/A	SW3.8 = OFF	SW3.8 = ON
	SW5.8 = ON	SW5.8 = OFF	SW5.8 = OFF

### 3.7 Detector Fitting

All detector heads should now be fitted to the bases (following the device installation guide), prior to the installation being tested.

The BiWire detectors can be configured for either latched or non-latching fire condition.

When the detectors are configured for latched mode then care must be taken that before any zone is re-enabled that a walk round of the zone is carried out to check that all detectors and manual call points are not latched in the fire condition.

If there are no detectors or manual call points showing the fire condition then the zone can be re-enabled at the panel.

---

 **WARNING**

---

FAILURE TO FOLLOW THE INSTRUCTIONS ABOVE WILL RESULT IN THE PANEL ENTERING A FULL ALARM CONDITION WHICH WILL EVACUATE THE SITE AND ACTIVATE ANY OTHER EQUIPMENT ATTACHED TO THE FIRE ALARM SYSTEM.

## 3.8 Installation Testing

### Initial Power-up Check

Power up the panel by engaging the fuse spur to supply mains, then connect the white socket of the battery cable to the power supply (see Figure 22).

Check that all indicators turn on in turn momentarily and turn off again.

Only the power on indicator should be lit afterwards.

Any fault indications should be investigated and corrective actions taken before continuing with the installation tests (see section 2.7 for fault indications). All corrective actions should be undertaken with the panel powered off.

If there are detectors or manual call points showing the fire condition then the panel should be reset to clear the fire condition before the zone is re-enabled. Check that the following outputs are in the correct state:

- Auxillary Output (30V)
- Fire Relay (C/NC)
- Fault Relay (C/NO)
- Interlink Relay (C/NC)
- FRE (0V, if fitted)
- FPE (0V, if fitted)

---

### WARNING

---

DO NOT FIX ANY FAULT CONDITIONS WITH THE SYSTEM STILL POWERED UP, THIS IS PARTICULARLY IMPORTANT WITH SHORT CIRCUIT FAULTS ON ZONES AS THE PTC FUSE NEEDS TIME TO RECOVER.

### Zone Fire Detection Check

Repeat the following per zone:

- Place the individual zone into Zone Test mode (see section 6.7).
- Activate a manual call point (or a detector if there is no call point on the zone) in that zone and then check the following:
  - General fire indicator (red) is on.
  - Correct zone fire indicator (red) is on.
  - All fire alarm devices are sounding.
- After approximately 3 seconds the system will automatically silence and the fire indication will clear.
- Take the zone out of Zone Test mode (see section 6.7).

Reset the system to clear all fire indications.

### Zone Fault Detection Check

Repeat the following per zone:

- Disconnect the last detector head on the zone then check the following
  - General fault indicator (amber) is on.
  - Correct zone fault/disable indicator (amber) is fast flashing for detector removed fault.
  - Fault relay has switched over to C/NC.

Connect the detector back on its base then check the following

- General fault indicator (amber) is off.
- Zone fault/disable indicator (amber) is off.
- Fault relay has switched back to C/NO.

Press button 5 "Mute Buzzer" to silence the panel buzzer.

### Battery Fault Detection Check

Disconnect the battery.

After about 20 seconds check the following:

- General fault indicator (amber) is on.
- Battery/Mains fault indicator (amber) is flashing for battery fault.
- Battery/Charger fault indicator (amber) is on for charger fault.

Connect the battery.

After about 4 seconds check the following:

- General fault indicator is off.
- Battery/Mains fault indicator is off.
- Battery/Charger fault indicator is off.

Press button 5 "Mute Buzzer" to silence the panel buzzer.

### Fire Outputs & Battery Check

---

 **WARNING**

---

THIS TEST WILL ACTIVATE ANY EXTERNAL EQUIPMENT CONNECTED TO THE FRE, FPE OR FIRERELAYS. IF THE ACTIVATION OF THE EQUIPMENT IS NOT DESIRED THEN THE EQUIPMENT MUST BE DISABLED, DISCONNECTED OR POWERED OFF DURING THIS TEST AND RESTORED ONCE THE TEST IS COMPLETE.

Measure the battery charger voltage, this should be around 27.6V.

Disconnect the mains supply and check the following:

- Power On (green) indicator is still on.
- General fault (amber) indication is on.
- Battery/Mains fault indication is on for mains fault.

The panel should not lose power during the following test.

Activate a call point in any zone.

Check the following on the panel:

- General fire indicator (red) is on.
- Correct zone fire indicator (red) is on.
- FRE On indicator (red) is on.
- FRE output has switched to 24V (if fitted).
- FPE output has switched to 24V (if fitted).
- Fire relay has switched over to C/NO.
- All fire alarm devices are sounding.

Check the following on the interlinked panel (if installed):

- General fire indicator (red) is on.
- FRE On indicator (red) is on.
- FRE output has switched to 24V (if fitted).
- FPE output has switched to 24V (if fitted).
- Fire relay has switched over to C/NO.
- All fire alarm devices are sounding.

Perform a soft reset and then check that the panel and interlinked panel have returned to the normal condition with mains fault.



## 4. Commissioning & System Handover

### 4.1 Commissioning

The walk test feature (see 6.10 for more details) has been provided to facilitate the commissioning of the BiWire Flexi system.

The commissioning of the system should be conducted in accordance to BS5839 part 1 Annex H.

The commissioning certificate must be completed and any variances noted.

The system configuration and variances should be recorded on the log book.

### 4.2 System Handover

The following documents must be handed over to the Premises Management of the installation:

- Zone map
- Commissioning certificate
- Log book
- User Manual

The Premises Management will be demonstrated the operation of the system and given basic training on the operation of the system and filling in the log book.

### 5. Maintenance

#### 5.1 Daily Testing

- To be conducted by the Premises Management.
- Check that the panel shows no fire or fault indications.
- If there are any fault conditions indicated then follow instructions in section 2.7.

#### 5.2 Weekly Testing

- To be conducted by the Premises Management.
- Each week perform a Lamp Test to check that all visual and audible indicators on the panel are functioning correctly (refer to section 6.8).
- Each week a different zone should be tested. Testing with a manual call point is the simplest method as these can be easily triggered with the key provided. Testing with a fire detection device is more complex as it requires specialist equipment and may not be possible for all premises. At a minimum a different manual call point should be tested each week.
- Place the zone to be tested into test mode using the "Individual Zone Test" (refer to 6.7 for more details)
- Record the weekly test results in the log book.

#### 5.3 Quarterly Testing

- To be conducted by the Competent Person.
- Check all previous log book entries and verify that any corrective actions had been taken.
- Carry out the weekly test and record the results in the log book.
- Visually inspect the batteries and their connections.
- Disconnect the mains supply and check that the fire system is capable of supplying the fire alarm devices by operating a call point.

#### 5.4 Yearly Testing

- To be conducted by the Competent Person.
- Carry out the weekly test and record the results in the log book.
- Carry out the Quarterly testing.
- Test **ALL** fire detection devices and manual call points.

## 6. Operating Instructions

### 6.1 Multi-Function Buttons



The numerical value in the center of the button is used to enter access codes for level 2 and 3.

If the text in the center of the button appears above a line (or there is no line) then this function is applicable at access level 2. If the text in the center of the button appears below a line then this function is applicable at access level 3.

The text above button 3 indicates that this button is the "Select" button during "Disable/Enable" and "Individual Zone Test" functions.

### 6.2 Silence Fire Alarm Devices

- This function is only available at access level 2 and when the alarms are sounding.
- Enter the access code 3112.
- Press the "Silence/Sound Alarms" button.
- Only the fire alarm devices will stop sounding, the panel buzzer will continue sounding.
- This function will immediately exit back to Access Level 1.



### 6.3 Sound Fire Alarm Devices

- This function is only available at access level 2 and when the alarms are silent.
- Enter the access code 3112.
- Press the "Silence/Sound Alarms" button.
- Only the General Fire indicator will be lit, the panel buzzer will sound a continuous tone and all fire alarm devices will sound.
- This function will immediately exit back to Access Level 1.



### 6.4 Reset System

- This function is only available at access level 2.
- Enter the access code 3112.
- Press the "Reset" button.
- This will stop all fire alarm devices sounding, will stop the panel buzzer and will reset the panel.
- The panel will return to the normal condition after completing the indicator test routine which turns each indicator on in turn and then turns them off in turn.



Note: When performing a reset, any test cases will be cleared

# Operating Instructions

## 6.5 Mute Buzzer

- This function is available at access level 1, 2 and 3.
- To silence the panel’s internal buzzer at access level 1 just press the “Mute Buzzer” button.
- To silence the panel’s internal buzzer at access level 2 enter the code 3112 and then press the “Mute Buzzer” button.
- To silence the panel’s internal buzzer at access level 3 enter the code 2321 and then press the “Mute Buzzer” button.
- This function will immediately exit back to Access Level 1.

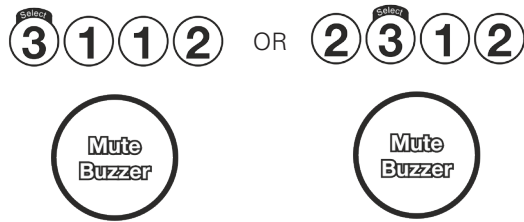

## 6.6 Enable/Disable

This function is only available at access level 2.

- Before re-enabling any zone that has latching detectors, a walk round of the zone in question should be carried out to check that all detectors and manual call points are not indicating a fire condition. Failure to do so will result in the panel entering a full alarm condition which will evacuate the site and activate any other equipment attached to the fire alarm system.
- This function will allow the following to be disabled:
  - Individual Zones
  - All fire alarm devices
  - FRE (if fitted)
  - FPE (if fitted)
- Enter the access code 3112.
- Press the “Disable/Enable” button (1).
- All previous disablements will have their associated disabled indicator lit and all enablements will have their associated disabled indicators unlit.
- The function always starts at Zone 1.
- When an item is selected for disablement its disable indicator will change from unlit to lit.
- Press the following button sequences for the required enablement/disablement:



- When an item is selected for enablement its disable indicator will change from lit to unlit.
- Pressing “Select” button (3) will accept the selected enablement/disablement and exit back to Access Level 1.

Item	2-Zone	4-Zone	8-Zone
Zone	3	3	3
Zone 2	1 + 3	1 + 3	1 + 3
Zone 3		1 (2 times) + 3	1 (2 times) + 3
Zone 4		1 (3 times) + 3	1 (3 times) + 3
Zone 5			1 (4 times) + 3
Zone 6			1 (5 times) + 3
Zone 7			1 (6 times) + 3
Zone 8			1 (7 times) + 3
Sounders	1 (2 times) + 3	1 (4 times) + 3	1 (8 times) + 3
FRE (if fitted)	1 (3 times) + 3	1 (5 times) + 3	1 (9 times) + 3
FPE (if fitted)	1 (4 times) + 3	1 (6 times) + 3	1 (10 times) + 3

## 6.7 Individual Zone Test

- This function is only available at access level 2.
- This function will allow individual zones to be placed in the zone test mode.
- Enter the access code 3112
- Press “Test” button (2).
- The zone currently in test mode will have its associated disabled indicator lit and all zones not in test mode will have their associated disabled indicators unlit.
- The function always starts at Zone 1.
- When an item is selected for test mode its disable indicator will change from unlit to lit.
- When an item is selected for normal operation its disable indicator will change from lit to unlit.
- Press the following button sequences for the required test mode/normal operation:



Item	2-Zone	4-Zone	8-Zone
Zone 1	3	3	3
Zone 2	2 + 3	2 + 3	2 + 3
Zone 3		2 (2 times) + 3	2 (2 times) + 3
Zone 4		2 (3 times) + 3	2 (3 times) + 3
Zone 5			2 (4 times) + 3
Zone 6			2 (5 times) + 3
Zone 7			2 (6 times) + 3
Zone 8			2 (7 times) + 3

- Pressing “Select” button (3) will accept the selected test zone and exit back to Access Level 1. The Test indicator will remain lit and the zone disabled indicator will also remain lit.
- When a fire detection device or manual call point is activated in the zone under test it will sound all fire alarm devices for 3 seconds and then will automatically silence.
- Any fire condition detected in any other zone will place the system into full alarm condition and the fire alarm devices will activate continuously.
- To end the individual test mode the above selection instructions should be carried out and the zone disabled indicator changed to the unlit state.

## 6.8 Lamp Test

- This function is available at access level 2.
- Enter the access code 3112.
- Press “Indicator Test” button (3).
- Each indicator on the front of the panel will turn on in turn and then turn off in turn (excluding the Power On indicator).
- This function will immediately exit back to Access Level 1.



# Operating Instructions

## 6.9 Self-test Mode

- This function is only available at access level 3.
- Enter the access code 2321.
- Press the "Test" button (2).
- The Test indicator will slow flash and the buzzer will give a slow pulsing tone.
- The fire indicator on every detector head will turn on.
- This function is useful for checking that each head is fitted correctly as the fire indicator will not turn on.
- To end the self-test mode, enter the access code 2321 and press button 2.



## 6.10 Walk Test Mode

- This function is only available at access level 3.
- Enter the access code 2321
- Press "Indicator Test" button (3).
- The Test indicator will turn on and the buzzer will give a slow pulsing tone.
- This function places all zones in test mode and is used during commissioning to test every fire detection device on a zone.
- Repeat the following for each zone (with fire detection devices) in turn:
  - Activate the fire detection device or manual call point on the zone.
  - All fire alarm devices will sound on all zones for 3 seconds and then will automatically silence.
  - The fire panel will then reset the zone from the fire condition.
  - Repeat the above process until all fire detection device and manual call points on the zone have been tested.
- To end the walk test mode enter the access code 3112 or 2321 and press the "Reset" button.
- If no fire detection device or manual call point is triggered within 10 minutes of the walk test being started, the test mode will timeout and return back to access level 1/normal condition.



## 7. Technical Specifications

### 7.1 Panel Specification

		<b>BiWire Flexi Fire Panel</b>		
		<b>EFBW2ZONE-FLEXI</b>	<b>EFBW4ZONE-FLEXI</b>	<b>EFBW8ZONE-FLEXI</b>
<b>POWER SPECIFICATION</b>				
Input Voltage Range		18.75-30.7V	18.75-30.7V	18.75-30.7V
Maximum current drawn from battery		2.7A	2.7A	2.7A
<b>ZONE CIRCUITS</b>				
<b>Number of Zones</b>		<b>2</b>	<b>4</b>	<b>8</b>
Devices Per Zone		BiWire Mode: Max of 32 BiWire Detectors and Manual Call Points, total loading including BiWire sounders cannot exceed 200mA in alarm Conventional Mode: Max 32 Conventional Detectors and Manual Call Points Intrinsically Safe Conventional Mode: Max of 10 Intrinsically Safe Detectors and Manual Call Point		
Maximum Loading Per Zone		200mA		
Standby Zone Voltage	Vmin	19V DC		
	Vmax	23V DC		
Alarm Zone Voltage	Vmin	31V DC		
	Vmax	33V DC		
Fuse Protection Per Zone		250mA PTC		
End of Line Termination		BiWire Zones = EOLM-3 Only Standard Conventional Zones = EOLM-1 Only Intrinsically Safe Zones = 6K8 resistor		
<b>CONVENTIONAL SOUNDER CIRCUITS</b>				
Number of Sounder Circuits		4		
Maximum Loading Per Circuit		500mA		
Fuse Protection Per Circuit		500mA PTC		
End of Line Termination		6K8 resistor		
<b>UNMONITORED OUTPUTS</b>				
Fire Relay	Type	Volt-Free, Single Pole Double Throw		
	Rating	30V DC, 1A		
	Fuse	500mA PTC		
Fault Relay	Type	Volt-Free, Single Pole Double Throw		
	Rating	30V DC, 1A		
	Fuse	500mA PTC		
Interlink Relay	Type	Volt-Free, Single Pole Double Throw		
	Rating	30V DC, 1A		
	Fuse	500mA PTC		

## Technical Specifications

Auxiliary Output	V	18.15-30.7V
	I <sub>max</sub>	50mA
	Fuse	50mA PTC
<b>UNMONITORED INPUTS</b>		
Class Change	Type	Open Circuit = Normal Panel Operation Short Circuit = Activate All Sounders
<b>COMMUNICATION PORTS</b>		
Repeater Port (use of this port is outside the scope of EN54 certification)	Type	RS485
	Nodes	1
<b>ENVIRONMENTAL</b>		
Operating temperature		-5 °C to +40°C
Relative Humidity		93% +/-3% non-condensing
IP Rating		IP30
<b>MECHANICAL</b>		
Dimensions		375mm Wide x 366mm Tall x 134mm Deep
Weight (excluding batteries)		2.25kg
Material		PC ABS Front and Rear
<b>CABLING</b>		
Cable Access		29 x 20mm drill positions - Slots for rear cable entry
Cable Type		Firetuf FT120 / FP200
		Cable type 2 core 1.5mm, 2 screened fire rated cable, 500m (max per zone)
<b>COMPLIANCE</b>		
Compliance to standards		EN54 Part 2 CIE & Part 4 PSE, BS5839-pt1



## 7.2 PSE Specification

		BiWire Flexi Fire Panel		
		EFBW2ZONE-FLEXI	EFBW4ZONE-FLEXI	EFBW8ZONE-FLEXI
<b>POWER SPECIFICATION</b>				
Mains Voltage	230V AC +10%/-15%, 50Hz			
Mains Fuse	1 Amp Anti Surge			
<b>PSE RATINGS</b>				
Number of Batteries	2			
Capacity	12V, 5Ah			
Recommended Battery	Yucell Y5-12 (Yuasa)			
Battery Fuse	6.3A Anti Surge			
Battery voltage (Charging Value)	27.3V DC @ 20°C			
Recommended period for battery replacement	5yrs			
<b>PSE RATINGS</b>				
Output Voltage	18.75-30.7V			
Maximum ripple voltage	425mVrms (1.2Vp-p)			
Imin	39mA			
I <sub>max.A</sub>	2.1A			
I <sub>max.B</sub>	2.6A			
Ri max	1Ω			
<b>PSE FAULT OPTIONS</b>				
MAINS OK (J4 pin4)	>=3V Mains present, <=3V Mains fault			
FAULT_CHARGER (J4 pin1)	>=3V for 1s pulsed at 0.2Hz Charger OK >=3V for 1s pulsed at 1Hz Charger fault Steady high/low (no pulsing) PSE Micro fault			
FAULT_BATTERY (J4 pin3)	=0.17*(Vbat-0.6) Volts			
0V (J4 pins2 and 10)	reference			

## 7.3 EOLM-3 Specification

		BiWire Flexi Fire Panel		
		EFBW2ZONE-FLEXI	EFBW4ZONE-FLEXI	EFBW8ZONE-FLEXI
<b>POWER SPECIFICATION</b>				
Operating Voltage	18.75-30.7V			
Nominal Current	1.7mA			

## 7.4 EOLM-1 Specification

		BiWire Flexi Fire Panel		
		EFBW2ZONE-FLEXI	EFBW4ZONE-FLEXI	EFBW8ZONE-FLEXI
<b>POWER SPECIFICATION</b>				
Operating Voltage	18.75-30.7V			
Nominal Current	1.4mA			

## 7.5 Option Board Specification

		<b>BiWire Flexi Fire Panel</b>		
		<b>EFBW2ZONE-FLEXI</b>	<b>EFBW4ZONE-FLEXI</b>	<b>EFBW8ZONE-FLEXI</b>
Operating Voltage		18.75-30.7V		
FRE Output	Rating	24V, 50mA		
	Fuse	50mA PTC		
	EOLR	6.8KΩ		
FPE Output	Rating	24V, 50mA		
	Fuse	50mA PTC		
	EOLR	6.8KΩ		
Number of Auxiliary Relays		2	4	8
Auxiliary Relays (Un-monitored)	Type	Volt-Free, Single Pole Double Throw		
	Rating	30V DC, 50mA		
	Fuse	500mA PTC		

## 7.6 Cable Specification

Recommended Cable Size 1-1.5mm<sup>2</sup>; Cable Type - Firetuf FT120 /FP200.



Manufacturer Draka UK to Standard - suitable for all applications described in BS 5839-1:2013, 6, 8 & 9 and BS5266-1.

## 8. Manufacturers Contact Details

Eaton Industries Manufacturing  
GMBH  
Electrical Sector EMEA  
Route de la Longeraie 7  
1110 Morges  
Switzerland

Technical Support:  
Tel: +44 (0)1302 303 350  
techsupport@cooperfire.com  
Cooper Lighting and Safety Ltd  
Wheatley Hall Road  
Doncaster  
South Yorkshire  
DN2 4NB  
<http://www.cooperfire.com>

Sales:  
Tel: +44 (0)1302 303 303  
sales@cooperfire.com



Eaton Industries Manufacturing GmbH, Electrical Sector  
EMEA, Route de la Longeraie 7, 1110 Morges Switzerland  
15  
DOP007

Eaton Industries Manufacturing GmbH, Electrical Sector  
EMEA, Route de la Longeraie 7, 1110 Morges Switzerland  
15  
DOP007

EN54-2  
EFBW8ZONE-FLEXI, EFBW4ZONE-FLEXI,  
EFBW2ZONE-FLEXI  
Intended for the use in fire detection and fire alarm systems  
in and around buildings

EN54-4  
EFBW8ZONE-FLEXI, EFBW4ZONE-FLEXI,  
EFBW2ZONE-FLEXI  
Intended for the use in fire detection and fire alarm systems  
in and around buildings

Essential Characteristics	Performance
Performance Under Fire Conditions	Pass
Response Delay (Response Time To Fire)	Pass
Durability Of Operational Reliability, Temperature Resistance	
Durability Of Operational Reliability, Vibration Resistance	Pass
Durability Of Operational Reliability, Electrical Stability	Pass
Durability Of Operational Reliability, Humidity Resistance	Pass

Essential Characteristics	Performance
Performance Under Fire Conditions	Pass
Response Delay (Response Time To Fire)	Pass
Durability Of Operational Reliability, Temperature Resistance	
Durability Of Operational Reliability, Vibration Resistance	Pass
Durability Of Operational Reliability, Electrical Stability	Pass
Durability Of Operational Reliability, Humidity Resistance	Pass

**Eaton Industries Manufacturing GmbH**  
Electrical Sector EMEA  
Route de la Longeraie 7  
1110 Morges, Switzerland  
Eaton.eu

**Eaton**  
Cooper Lighting and Safety Ltd  
Wheatley Hall Road  
Doncaster, South Yorkshire  
DN2 4NB  
T: +44 (0) 1302 303 303  
E: [MVDO-Fire-TechSupport@Eaton.com](mailto:MVDO-Fire-TechSupport@Eaton.com)  
W: [www.cooperfire.com](http://www.cooperfire.com)

© 2016 Eaton  
All Rights Reserved  
Printed in UK  
March 2016

Eaton is a registered trademark.

All other trademarks are property  
of their respective owners.