

# BiWire 5 in 1 Detector



EFBW5IN1DET are conventional detectors, compatible with the BiWire Ultra range of fire panels. They can be configured to operate as either an optical smoke detector, opto/heat multi sensor detector or 1 of 3 heat detector modes using the four position switch located at the back of the detector (see table for switch settings)

**Optical smoke detector.** This detector is suitable for most applications giving the fastest response to slow burning or smouldering fires which give rise to large visible smoke particle.

**Opto-heat detector.** This will respond better to fast clean burning fires yet maintain the advantage of optical detectors when detecting smouldering fires. The thermal enhancement of this detector allows a higher alarm threshold which provides a greater rejection of false alarms. The detector will also give an alarm at temperatures above 60°C (Heat class A2S).

**Rate of Rise heat detector (Class A1R).** This detector will detect a rapid increase in temperature or temperatures above 60°C and should be used in environments where the ambient conditions might cause false alarms if smoke detection were to be used, for example where there is a high level of dust, fumes, steam or smoke under normal conditions.

**Fixed (77°C – Class BS) heat detector.** This detector will detect temperatures above 77°C and should be used in environments where the ambient conditions might cause false alarms if smoke detection were to be used, for example where there is a high level of dust, fumes, steam or smoke under normal conditions.

**Fixed (92°C – Class CS) heat detector.** This detector will detect temperatures above 92°C and should be used in environments where the ambient temperature is likely to be high i.e. boiler rooms.

In the Optical and Opto-Heat mode the detector automatically compensates for gradual increase in the scatter signal due to contamination e.g. dust build up.

These detectors can be instructed to blink their yellow LED every 2 seconds by a command from the main panel, to aid the search for a break in the zone cabling.

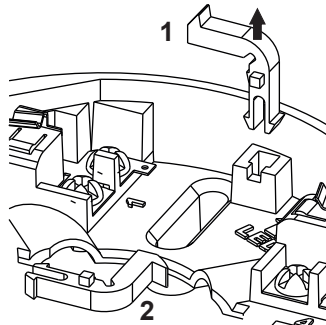

**Utilising locking tab**  
The mounting base includes an optional feature to prevent the removal of the detector without a tool.

1. Remove the standard fit retaining clip
2. Insert the locking clip which is located at the center of the base as shown.

Mount the detector onto the base as described in detector installation (see over) and rotate fully clockwise until it finally clicks.

The detector is now locked into position, remove by utilising a suitable tool (e.g. a thin screw driver) into the hole in the detector cover. Gently push the tool into the detector and rotate anti-clockwise.

#### FXN520 base specification

- Supply Voltage: 15-35 V DC
- Cable Size: 0.5 - 2.5mm<sup>2</sup>
- Mounting hole centers: 50 - 80mm
- Recommended cable types: FIRETUFF or FP200

#### Detector Installation

- Fit detector to mounting base and rotate clockwise until the detector drops into place.
- Continue to rotate clockwise until the detector clicks into place and the marker on the detector lines up with the marker on the base.
- If the detectors are required to be locked into position, refer to the mounting base installation instructions (see above).
- Smoke detectors are supplied fitted with dust covers for general protection against airborne contaminants. These must be removed from all detectors before the fire system is commissioned.
- NB. These dust covers do not provide adequate protection against quantities of dust generated by building work, sanding etc. Therefore, detectors should not be installed until this type of work has been completed.

#### Applicable Standards

EN54-7:2000 +A1:2002 + A2:2006  
EN54-5:2000 + A1:2002 Class P  
CEA 4021:2003-07

#### Declaration of Performance

DOP0015



Powering Business Worldwide

Operating voltage	15 to 35 Vdc	
Standby current (max)	80uA	
Alarm current (typ)	20mA	
Ambient temperature (max)	Opto mode	60°C
	Opto-Heat mode	45°C
	60°C Rate of Rise mode	45°C
	77°C Fixed Temp mode	60°C
	92°C Fixed Temp mode	80°C
Ambient temperature (min)	-10°C	
Alarm temperature in heat modes (static)	60°C A1R	
	77°C BS	
	92°C CS	
Heat detector class –as defined by EN54-5:2000	A1R/BS/CS Programmable	
	A2S (Opto/Heat Mode)	
Relative humidity	0 to 95%	
Height (without base)	43mm	
Height (with base)	56mm	
Diameter	104mm	
Weight (without base)	78g	
Material	PC/ABS	
Colour	White	
Compatible base	FXN520	

**Maintenance**

Only minimal maintenance can be performed on this range of detectors as they do not contain any site serviceable parts. The frequency of maintenance will depend on the environment to which the detector is exposed but should be at least annually. Dusty or damp environments will demand more frequent maintenance.

Remove the detector from its mounting base. Use a vacuum cleaner to remove dust build up from around the smoke entry apertures of a smoke detector, or from around the heat sensing element of a heat detector.

For smoke detectors, visually inspect the insect mesh for blockages. If these can not be cleared by vacuuming, the detector must be replaced. Re-fit detector to its mounting base and test as described above.

**Wiring Hints**  
 Each terminal is suitable for clamping up to 2 wires  
 Clamping of 2 wires of very different diameters under one screw is not recommended.  
**DO NOT USE A POWER TERMINAL DRIVER.**  
 Suitable for mounting to mounting boxes with 50-80mm fixing centres.

**Testing**

All detectors must be tested following installation or routine service and maintenance. It is recommended that these tests are carried out by a competent person. Authorised personnel must be informed that the fire system will be temporarily out of service before commencing testing. To prevent unwanted alarms, ensure that the panel is in test mode and it may be appropriate to disable some or all of the sounder circuits. When all tests are complete, restore panel to normal operation and notify authorised personnel that the system is operational.

**Smoke Detectors:**  
 Subject the detector to be tested to a controlled amount of an approved synthetic smoke aerosol via a smoke detector test pole. Suitable products are available for example, from No Climb Products Ltd. Check that the red LED on the detector latches into alarm within 30 seconds. If an optional remote LED is fitted, check that this also lights. Ensure that the control panel activates into alarm. Reset the detector from the control panel unless automatically reset by the panel in test mode. This procedure will test the smoke sensing circuitry of the Photo/Thermal Detector.

**Heat Detectors:**  
 Using a heat gun or hair dryer capable of generating temperatures of up to 95°C, direct the heat source towards the heat sensing elements, visible through the side of the outer cover, from a distance of 15 to 30cm. Care should be taken not to allow the plastic surface temperature to exceed 110°C otherwise damage may occur. When the temperature reaches the 'Alarm Temperature' (see Specifications above), check that the red LED on the detector latches into alarm. If an optional remote LED is fitted, check that this also lights. Ensure that the control panel activates into alarm. Reset the detector from the control panel unless automatically reset by the panel in test mode. This procedure will test the heat sensing circuitry of the Photo/Thermal Detector.

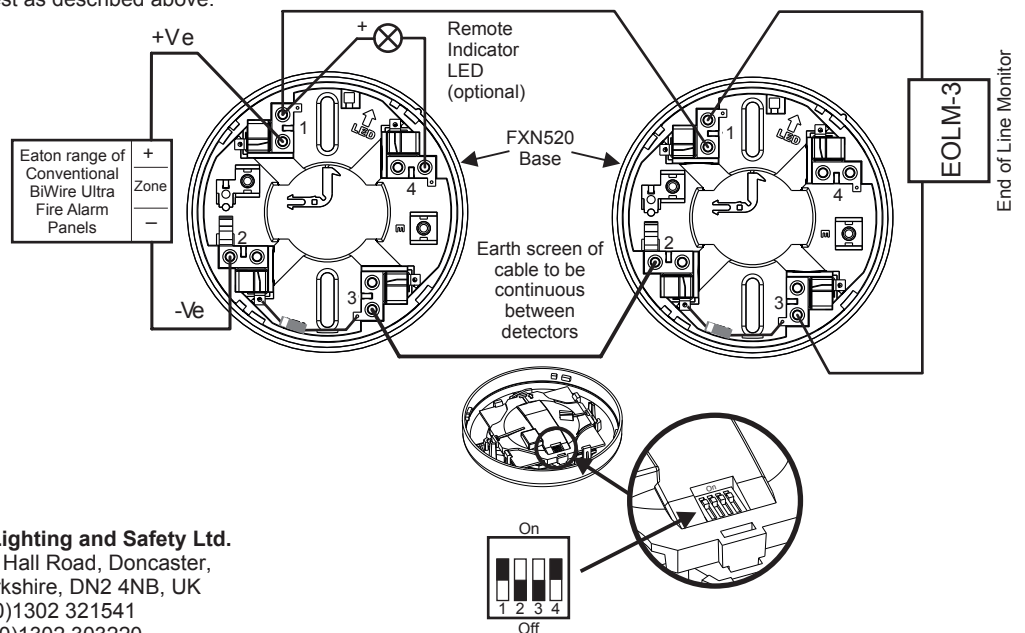

**Cooper Lighting and Safety Ltd.**  
 Wheatley Hall Road, Doncaster,  
 South Yorkshire, DN2 4NB, UK  
 Tel: +44(0)1302 321541  
 Fax: +44(0)1302 303220  
 www.cooperfire.com  
 www.eaton.com

**Eaton Industries Manufacturing GmbH**  
 Electrical Sector EMEA  
 Route de la Longeraie 7  
 1110 Morges, Switzerland  
 Eaton.eu

Description	SW1	SW2	SW3	SW4
Opto	N/A	Off	Off	Off
Opto/heat	N/A	Off	Off	On
Rate of rise heat A1R	N/A	On	Off	Off
Fixed heat BS	N/A	On	Off	On
Fixed heat CS	N/A	On	On	Off
Non latching alarm (auto reset)	On	N/A	N/A	N/A
Latching alarm	Off	N/A	N/A	N/A