

Visual Alarm Devices - VADs

A pocket guide to planning, design,
installation, commissioning and maintenance
of VADs for Fire Warning

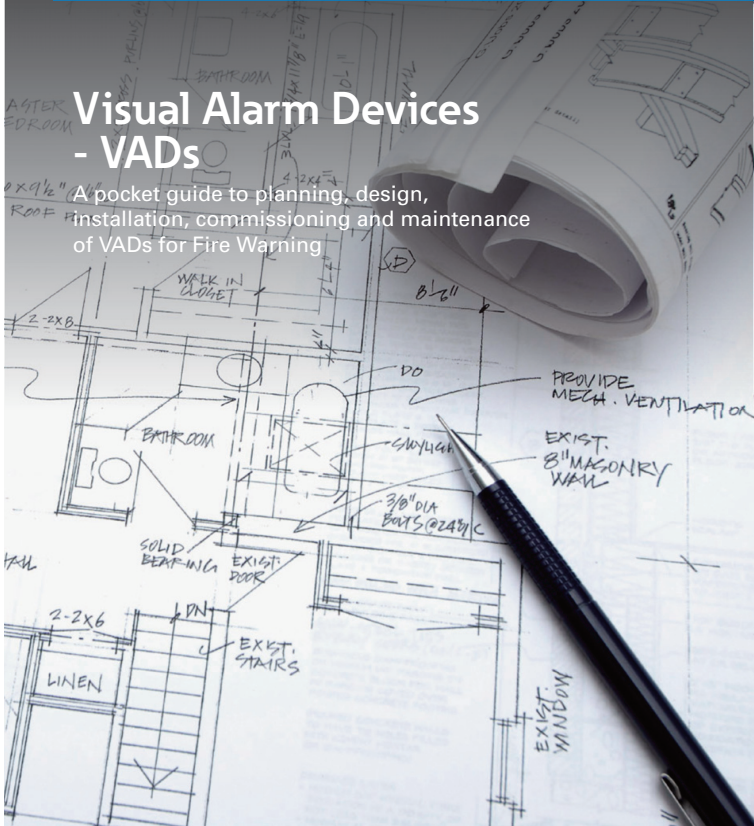



Eaton and Cooper united. Energizing a world that demands more.

We deliver:

- **Electrical solutions** that use less energy, improve power reliability and make the places we live and work safer and more comfortable
- **Hydraulic and electrical solutions** that enable machines to deliver more productivity without wasting power
- **Aerospace solutions** that make aircraft lighter, safer and less costly to operate, and help airports operate more efficiently
- **Vehicle drivetrain and powertrain solutions** that deliver more power to cars, trucks and buses, while reducing fuel consumption and emissions

Discover today's Eaton.

Powering business worldwide

As a global diversified power management company, we help customers worldwide manage the power needed for buildings, aircraft, trucks, cars, machinery and businesses.

Eaton's innovative technologies help customers manage electrical, hydraulic and mechanical power more reliably, efficiently, safely and sustainably.

We provide integrated solutions that help make energy, in all its forms, more practical and accessible.

With 2012 sales of \$16.3 billion, Eaton has approximately 103,000 employees around the world and sells products in more than 175 countries.

Eaton.com

EATON

Powering Business Worldwide



Contents

<i>Page</i>	<i>Title</i>	<i>CoP 0001 Clause</i>
5	Introduction to VADs (Visual Alarm Devices) and - CoP 0001 Overview	
6	Ceiling Mounted Devices	4.6.3
7	Wall Mounted Devices	4.6.3
8	Open Class Devices	4.6.3
9	External Factors	4.6.4 - 4.6.8
10 -11	General rules for Selection and Siting	4.6.9.2
12	Coverage Distance Multiplication Factors	4.6.9.3
13	Power Supplies	4.7
14	Wiring	4.8
15 - 16	Installation and Commissioning	5.1 - 6
17	Maintenance	7.1 - 7.3
18	The LX range	-
19	Tools, Guides and References	-

Note: Radio Linked Systems

This pocket guide does not cover Radio Linked Systems. These are a specialised system, and are covered in a separate document. Please contact customer service for further guidance.

Visual Alarm Devices - VADs

A pocket guide to planning, design, installation, commissioning and maintenance of VADs for Fire Warning.

Foreword

In a fire alarm system the purpose of Visual Alarm Devices (VADs) is to compliment the audible alarm signal with a visual one. This may be required in areas where people are unable to hear the alarm signal, either due to a hearing disability or local conditions such as high noise levels or the need to wear ear defenders.

Until recently, Visual Alarm Device performance has been specified in an inconsistent, confusing and often misleading way. The use of Joules, Watts and Candela to specify a VADs performance are all largely meaningless, as they do not take into account the effectiveness of the visual signal over a given area.

With the introduction of the European standard EN 54-23, manufacturers are able to specify visual devices in terms of the range at which the required illumination is met. In the case of EN 54-23, the required illumination is 0.4 lux or 0.4lm/m².

Note:

The 'required illumination' is the minimum level of light likely to attract attention.

Three categories of devices are defined, one for ceiling mounted devices, one for wall mounted devices, and an open category. These are tested and assessed by the laboratories of an EU notified body and are then certified as meeting the requirements of EN 54-23, at a specified coverage volume.

For example, at a given mounting height, the coverage area of a VAD is defined by the diameter (ceiling device) or width (wall device) of the coverage, given in metres. This will more readily enable designers to set an appropriate coverage distance between VADs and assess that all relevant areas covered by VADs are adequately specified.

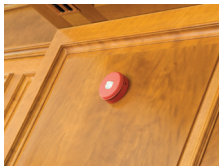

Introduction to VADs (Visual Alarm Devices)

Visual Alarm Devices, or VADs, would generally be required where an audible alarm would not be effective or practical, or where further re-enforcement of the audible alarm is required.

Typical situations include: -

- Compliance with the Equality Act 2010 (UK only) local building regulations or related legislation
- Warning deaf or hard of hearing people of an emergency
- Areas of high ambient noise
- Staff restricted warning systems
e.g.: -
 - nursing homes or hospitals
 - certain public assembly buildings
- Broadcast studios
- Hospital operating theatres



Overview of CoP 0001

CoP 0001 provides guidance and recommendations on the planning, design, installation, commissioning and maintenance of VADs.

- VADs assumed to conform to EN 54-23
- Complements BS5839-1, BS8300 and BS9999
- Use alongside building regulation and regional requirements
- VAD coverage volume clearly defined
 - Required illumination is defined as 0.4 lux
- Common visual signal required throughout a building
- White or red flash allowed (for single stage alarm)



✓ TopTip

Consider performing an on-site assessment or survey to review the best use and location for your VADs.

Ceiling Mounted Devices - C-x-y

C – Ceiling Mounted Device

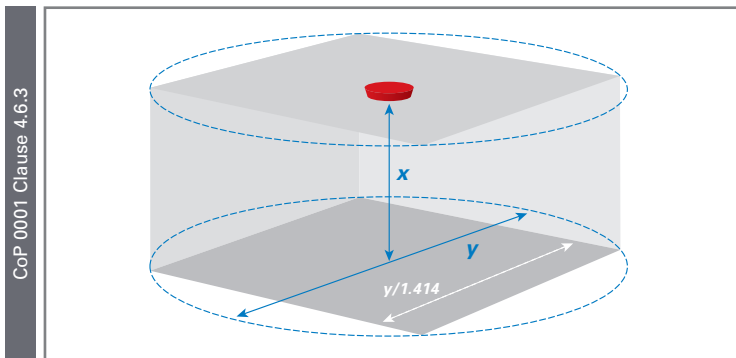

- x** – The maximum height of either 3, 6 or 9 m at which the VAD may be mounted
- y** – The diameter in metres of the cylindrical volume covered (to a minimum level of 0.4 lux) when the device is mounted to the ceiling at a height of 3, 6 or 9 m

Example:

C-3-15 corresponds to a ceiling-mounted device giving a coverage cylindrical volume of 15 m, when mounted at 3 m.

Note:

The protected space sits within the cylindrical volume and ensures that all areas meet the required illumination of 0.4 lux.

✓ TopTip

To convert the coverage diameter **y** to the width of a square room
Width of square room = $y / 1.414$ m

Wall Mounted Devices - W-x-y

W – Wall Mounted Device

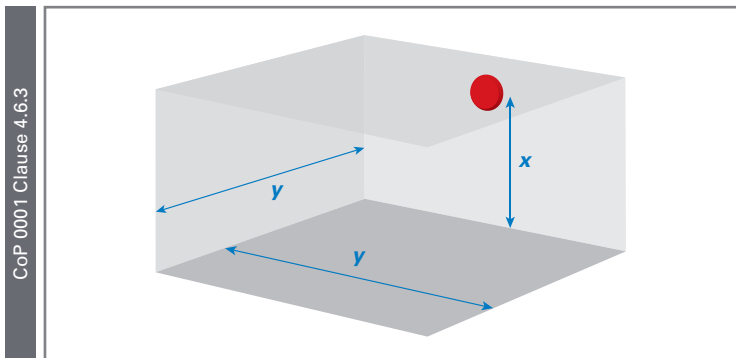

x – The maximum height of the device on the wall in metres, with a minimum value of 2.4m

y – The width in metres of the square volume covered (to a minimum level of 0.4 lux) when the device is mounted to the wall at a height x

Example:

W-2.4-7.5 corresponds to a wall-mounted device giving a coverage cuboid volume of 2.4 m x 7.5 m x 7.5 m, when mounted at a height of 2.4 m.

✓ TopTip

- If the area to be covered is not square, use the larger of either the length or width to ensure that the whole area is covered.
- If the distance (**y**) measured above is greater than the VADs rated coverage, then several devices will be required to cover the area.

Open Class Devices

O – Open Class Device (coverage volume specified by manufacturer)

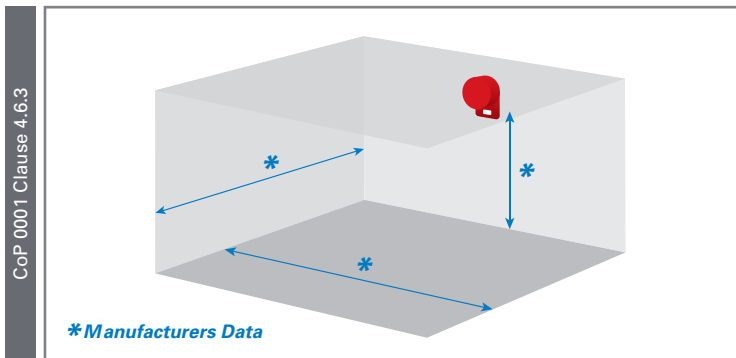

Open class devices do not conform to either the Wall or Ceiling category. However, they still need to meet the required illumination of 0.4 lux over their specified range.

Manufacturer's specification will include: -

- the mounting position
- the mounting orientation
- the minimum and maximum mounting height
- the shape, dimensions and orientation of the coverage volume (0.4 lux)

Example:

O-Corridor VAD

Mounting position - centre of wall at end of corridor as shown above

Orientation - with beacon at base of unit

Mounting Height = 2.0 – 3.0 m

Coverage volume – 0.4 lux polar dispersion data issued by manufacturer

External Factors

External factors, such as ambient light levels or the environment can have a significant influence on the effectiveness of VADs. It is important to consider what effect these external factors may have.

CoP_0001 Clause 4.6.4 – 4.6.8

Main consideration factors: -

- **Ambient light level**
Will artificial light and natural light be a factor (time of day, etc)
- **Reflective surfaces**
Are walls or other surfaces matt or shiny, etc.?
- **Field of view**
Is the light visible from the VAD 'directly' or 'indirectly'
e.g. light reflected from an adjacent surface would be indirect
- **Use of tinted eye protection**
Is the VAD to be used in an industrial environment, where personal protective equipment (PPE) may be in use, etc.?
- **The environment**
Indoor Type A devices – IP21C, Outdoor Type B devices – IP33C

IP (Ingress Protection) ratings

Eaton's Fulleon's products may have higher IP ratings than that required by EN 54-23. This can offer a device that is more flexible for a wider range of applications or uses beyond standard practice.

IP ratings – Good Practice

- Use a higher IP rating, if the device is to be used in high humidity or damp conditions
- Use suitable cable glands to maintain the specified IP rating
- Ensure the correct product orientation
- Ensure all base and mounting screws, or fixings are secure

Please consult the relevant Installation Guide, Product Manual and our website for further details on specific products.

TopTip

You may need to perform an on-site assessment or survey to assess the ambient light levels, environmental conditions and other relevant factors. A lux meter complying with BS667 will be needed to assess ambient light levels.

General rules for selection and siting

- **Wall mounted VADs are likely to be effective in a wide range of applications**
 - Suitable for higher ambient light levels and the preferred choice for general applications
- **Ceiling mounted VADs are suitable for broad coverage in regular shaped rooms**
 - However, they are more likely to be affected by higher ambient light levels
 - Can be used as an alternative to wall mounted devices and are more practical to install in large open areas
- **Open category VADs should take into account manufacturers recommendations**
 - Care should be taken that minimum illumination level of 0.4 lux is met throughout the area
- **Applications where there is continuous surveillance of a VAD in a specific direction, may not require widespread coverage**
 - A seated auditorium or a broadcast studio may only require limited coverage
- **Where possible, site the VADs for direct viewing for all occupants in an area**
 - If this is not possible, consider the minimum illumination on adjacent reflected surfaces
- **If relying on indirect illumination, the reflecting surfaces should be within the coverage area of the VAD**
 - The 'coverage area' is that stated for the VAD, multiplied by the coverage distance multiplication factors in the table on page 11
 - The indirect illumination may be reduced, if a formal assessment determines negligible risk
- **Where an area to be covered is larger than the coverage area of a single VAD, a sufficient number of extra VADs should be sited appropriately**

General rules for selection and siting

- **Dependence on direct line of site should not be relied upon, if the VAD is used where deaf or hard-of-hearing people may be alone for prolonged periods**
 - Applies particularly to hotel bedrooms and bathrooms
 - Also applies to people wearing ear defenders or where they may be working alone or focusing on specific activity
- **Before selecting a VAD for a specific area, the ambient light level should be determined**
 - Ambient level should be the maximum anticipated at any time
 - The ambient light level may be reduced by measures such as blinds or curtains on windows.
 - Consult the building designer when selecting VADs at the planning stage of a new build
 - A lux meter complying with BS 667 should be used to determine the average ambient light levels. (see CoP 0001 4.6.9.2. j)
- **In the case of stairwells, the illumination from a VAD should satisfy the recommendations of this CoP across the area of each landing**
 - Compliance may not be necessary throughout the stairway



Coverage Distance Multiplication Factors

Multiplication factors should only be used after careful consideration of the application, including prevailing ambient light level and the need to rely on indirect, rather than direct illumination.

Table 1 gives multiplication factors that can be applied to the coverage distance for VADs certified to EN 54-23. These may increase, or decrease the specified coverage volume stated by the manufacturer of the device.



Table 1. Coverage Distance Multiplication Factors

CoP_0001 Clause 4.6.9.3	Ambient light level (lux)	Ceiling mount direct view	Ceiling mount indirect view	Wall mount direct view	Wall mount indirect view
	< 100	2.8	1.3	5.2	1.8
	100 to 200	2.4	1.2	4.4	1.7
	200 to 300	1.9	1.0	3.2	1.4
	300 to 400	1.4	0.8	2.3	1.2* see below
	400 to 500	1.1	0.6	1.8	1.0
	500 to 600	0.9	0.5	1.3	0.9
	600 to 700	0.7	0.4	1.0	0.7
	700 to 800	0.5	0.3	0.7	0.6

Example:

A wall mounted VAD with a rating W-2.4-7.5 is to be used in a location where the ambient light level is 350 lux and the view is considered to be indirect.

From the table, multiply the rated coverage distance of 7.5m, by the factor 1.2*. The mounting height may also be multiplied by 1.2*.

This gives a final coverage of $7.5 \times 1.2 = 9$ m mounted up to a height of $2.4 \times 1.2 = 2.88$ m

The VAD can therefore be used in this location, as if it were rated W-2.88-9

TopTip

It is sometimes better to try and control the light level in a room, rather than design a solution for a room bathed in direct sun light.

Power Supplies

Power supplies should be compliant with BS EN 54-4 and the recommendations of BS5839-1. In particular, the following points apply: -

- Both the normal and standby supply should each be independently capable of supplying the maximum alarm load imposed by the system, irrespective of the condition of the other supply
 - High peak loads which may be imposed by VADs should be taken into account
- The high peak power requirements of any VAD connected to a system should have no effect on any other function
- Manufacturers of VADs and power supply equipment should make available sufficient information to allow the compatibility of power supplies to be assessed
 - Data should be available on request (see below)

Power supplies with larger installations - example

- Power supply should be capable of providing a current of at least $1.2 \times$ total VAD operating current.
- Power supply surge capability should be at least $1.5 \times$ the total VAD surge current for at least 10mS.
- A suitable slow-blow fuse must be fitted to the output stage of all power supplies.
- Where a large number of units are to be wired, it is recommended to use multiple power supplies on separate spurs to avoid large voltage drops that would otherwise be encountered. See below: -

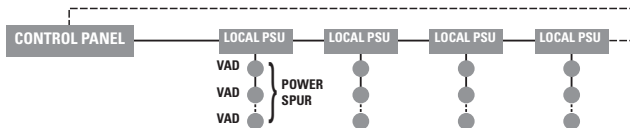

✓ TopTip

Fulleon's product manuals give practical advice on what to consider when specifying power supplies for a VAD based system. The relevant product manual is referenced on the Installation Guide with each product and can be accessed via our website.

Wiring

CoP 0001
Clause 4.8

Cables serving VADs should conform to the recommendations of BS 5839-1 clause 26.2

- ... to ensure that cables used in circuits of VADs remain operational for an adequate duration, cables with an inherent ability to resist attack by fire need to be used

Cable resistance and run length - example

It is important that the series resistance (R_s) of a given cable is known, as this can have a significant effect on the on the maximum length of cable run possible.

The following table gives an indication of the cable lengths that could be used with a typical setup and is based on solid core wire with a cross sectional area (CSA) of 1.0mm^2 . If using a different CSA, cable type or a material other than copper, the value of the series resistance of the cable (R_s) will change significantly and will need to be factored into the calculations accordingly.

Please note that that all devices are assumed to be wired to the end of a spur, as this is the worst case scenario.

Typical Wiring Calculations (Solista LX Wall) for example purposes ONLY

Number of products (N)	Typical max current consumption of product (Is) - Amps	Typical power supply steady state capability (Ip) - Amps	Max cable resistance for 10% voltage drop @ 18Vdc (Rc) - ohms	Max cable length for 10% voltage drop @ 11.18Vdc (L) - Meters
1	0.15	0.18	12	333
2	0.30	0.36	6	167
3	0.45	0.54	4	111
4	0.60	0.72	3	83
5	0.75	0.90	2.4	66

* Note: Cable is assumed to be copper, with a resistance of $1.8\Omega/100\text{m}$. All calculations and advice is given for guidance ONLY. No liability is assumed for the use of these calculations or advice, or for any errors or omissions. The installer is responsible for ensuring that the product is installed and wired correctly and safely using all relevant and current wiring regulations and practices.

TopTip

If longer cable runs are required than those given in the example above, larger gauge cables should be specified, to reduce the effects of the cable resistance.

Installation and Commissioning

CoP 0001 Clause 5.1

Responsibility of installer

- **Consult with all relevant parties**
 - This may include user or purchaser, designer, VAD supplier, architects, fire consultants, etc.
- **Report and document any variations not already identified (usually noted on the design certificate)**
- **Separate all metallic parts of the installation from any metalwork forming part of lightning protection**
- **Include VADs in any “as fitted” drawings, if this is down to the installer**
- **Ensure mains supplies comply with BS5839-1 Clause 25.3 and 25.4**
- **Supply separate electrical installation certificates (BS7671) for any separate mains supplies powering VAD’s.**
- **Sign an installation certificate of the type recommended in BS5839-1, Annex G2.**

CoP 0001 Clause 5.2 & 5.3

Installation Practices and Workmanship (inc. Inspection and Testing of Wiring)

- **Installation should comply with BS5839-1 Clause 37.1 and 37.2**
- **To achieve the correct light coverage, follow the VAD manufacturer’s recommendations**
 - This will include correct mounting height and orientation to achieve the required illumination
- **Mounting bases with suitable ingress protection (IP ratings) should be selected for the location**
- **VADs should be sited, so that they do not form a protrusion hazard**
- **Wiring should be inspected and tested in accordance with BS5839-1 Clause 38.1 and 38.2**

Installation and Commissioning (continued)

Commissioning should be carried out in accordance with BS5839-1 Clause 5, in addition: -

- The position and ratings of VADs should comply with CoP 0001 4.6.9 and system design drawings
- All VADs used for indication of a fire alarm should produce the same colour flash within the building
- VAD's must not be confused with any other visual alarm signal within the building
- Where multiple VADs are visible from any single point, they should meet the synchronisation requirements of CoP 0001 Clause 4.3.6.2 (f) and 4.5.4
- Documentation should include "as fitted" drawings showing location and light output ratings of all VADs, in addition to any documents or certificates required by BS5839-1



✓ TopTip

It may be wise to mark up any site plans or drawings with VAD locations and settings as they are commissioned. This may save time and effort later.

Maintenance

CoP 0001 Clause 7.1

Documentation

- **BS 5839-1 recommends that fire detection and alarm systems are tested weekly**
 - This can provide an opportunity for occupants to report any instances of poor visibility or non operation
- **Instructions to occupants should be to note any instances of poor visibility and report**
 - This also provides an opportunity for occupants to become familiar with the VAD signals
- **Staged systems with a separate alert and alarm, should have both states tested**
 - Where practical, stages should be activated sequentially in the order that they would occur at the time of a fire (i.e. 'Alert' then 'Evacuate')

CoP 0001 Clause 7.2 & 7.3

Inspection and Servicing (inc. non-routine attention)

- **Inspection and servicing of equipment and circuits serving VADs and the VADs themselves, should comply with BS 5839-1 Clause 45**
 - The correct operation of all circuits serving VADs should be confirmed at this time
- **The operation, and where applicable, the synchronisation of each VAD should be checked annually as a minimum**
 - The lens should be cleaned to remove any dirt or deposits (where necessary)
 - Confirm that the VADs are not obstructed from view
- **Non routine attention should be carried out in accordance with BS 5839-1 Clause 46**
 - VADs no longer providing adequate coverage should be identified to the responsible person appointed by the user
 - After any fire, affected VADs and circuits should be inspected / tested. VADs should be checked and cleaned of any soot or other deposits

TopTip

Regular inspection, servicing and maintenance of VAD systems is important to help ensure the integrity and performance of the system.

Overview of the LX Range

Delivering low current, with maximum coverage, the LX Range developed by Eaton's Fullleon Business has been specifically designed to provide an efficient solution to the new EN 54-23 standard.



Solista LX Wall

- Slim Line Design
- Easy Installation
- Consumption as low as 10mA



RoLP LX Wall

- Proven Roshni Sounder
- Beacon Base Option
- Retrofit Sounder Option



Symphoni LX Wall

- Proven Sounder
- Low Current
- Beacon Base Option



Symphoni WP LX Wall

- Weatherproof Design
- Low Current Consumption
- Proven Sounder



Solista LX Ceiling

- Slim Line Design
- Easy Installation
- Consumption as low as 10mA



Squashni G4 LX Ceiling (certification pending)

- Large Coverage Area, 15m
- See website for more details

Key Specifications for LX Beacon Range

Type	Mounting Height	Red and White Flash				Hz	mA
		Cylindrical Diameter	Room Length	Room Width			
Ceiling	3m	7.5m	5.3m*	5.3m*	1	25	
<i>Standard Power</i>	3m	7.5m	5.3m*	5.3m*	0.5	16	
Ceiling	3m	3m	2.1m*	2.1m*	1	16	
<i>Low Power</i>	3m	3m	2.1m*	2.1m*	0.5	10	
Wall	2.4m		7.5m	7.5m	1	25	
<i>Standard Power</i>	2.4m		7.5m	7.5m	0.5	16	
Wall	2.4m		2.5m	2.5m	1	16	
<i>Low Power</i>	2.4m		2.5m	2.5m	0.5	10	

**Use these measurements for calculating the size of the square within the cylindrical coverage.*

Tools and Resources

- **Specification Design Templates**
 - fulleonCS@eaton.com
- **Download Product Datasheets and Brochures**
 - www.cooperfulleon.com
- **Fulleon Product Support**
 - fulleonCS@eaton.com
- **VADs Online Specification Tool**
 - www.cooperfulleon.com

Disclaimer

This booklet is not intended to be a comprehensive guide to all aspects of VADs and VAD system installations, but rather a useful source of background information.

Whilst every care has been taken to ensure that the contents of this document are correct at the time of publication, it should never be used as any form of substitution for the current issues of CoP 0001, BS 5839, or any other regulatory or legislative documents. Cooper Fulleon shall be under no liability whatsoever in respect to such contents.

It should be noted that there may be specific additional requirements that may need to be taken into account, dependent upon local authority building regulations, fire authority and/or building risk assessment.

Please use this guide in conjunction with CoP 0001, BS5839 and other relevant CoP's or applicable standards.

Eaton is dedicated to ensuring that reliable, efficient and safe power is available when it's needed most. With unparalleled knowledge of electrical power management across industries, experts at Eaton deliver customized, integrated solutions to solve our customers' most critical challenges.

Our focus is on delivering the right solution for the application. But, decision makers demand more than just innovative products. They turn to Eaton for an unwavering commitment to personal support that makes customer success a top priority. For more information, visit www.eaton.com/electrical.

Eaton Industries Manufacturing

GmbH
Electrical Sector EMEA
Route de la Longeraie
71110 Morges, Switzerland
Eaton.eu

Cooper Fulleon Limited

Llantarnam Park
Cwmbran, Gwent, NP44 3AW
Tel: +44 (0)1633 628 500
Fax: +44 (0)1633 866 346
www.cooperfulleon.com

Eaton is a registered trademark.