

# Solista LX Ceiling

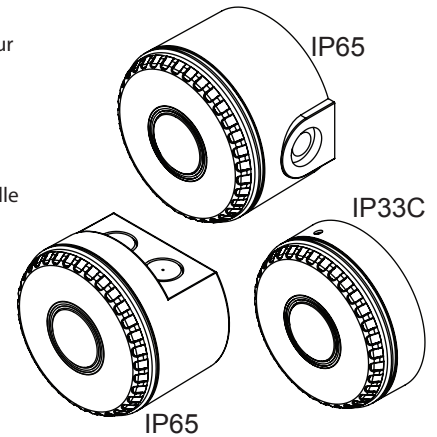

- (EN) EN54-23 Fire alarm devices visual alarm device for use in & around buildings
- (FR) Dispositifs incendie EN54-23 dispositifs visuels alarme feu pour utilisation à l'intérieur et autour des bâtiments
- (DE) EN54-23 Feuermeldevorrichtung Optischer Signalgeber zur Innen-und Aussenmontage
- (PL) EN54-23 Pożarowe urządzenia alarmowe sygnalizatory optyczne do pomieszczeń i na zewnątrz budynków.
- (IT) Dispositivi di allarme antincendio EN54-23 dispositivo di allarme visivo per uso all'interno e nelle vicinanze degli edifici



DoP No: 0333-CPD-075443

	EN54-23:2010		ABS FR & Polycarbonate
	9 - 60Vdc		Type A (IP33C) & B (IP65)
	-25°C ~ +70°C		1.5W (max)
	3m (max)		100mS ON / 900mS OFF 50mS ON / 950mS OFF
	< 120% for 10mS		0.5mm <sup>2</sup> - 2.5mm <sup>2</sup>

	High Power			Low Power	
	1 Hz	0.5Hz		1 Hz	0.5Hz
	C-3-7.5 7.5m (132m <sup>3</sup> )			C-3-5 5m (58.9m <sup>3</sup> )	
	12V	51mA	27mA	35mA	19mA
White Flash Flash Blanc Weisser Blitz	24V	25mA	16mA	16mA	10mA
	48V	18mA	11mA	11mA	9mA
	C-3-7.3 7.3m (126m <sup>3</sup> )			C-3-3 3m (21.2m <sup>3</sup> )	
	12V	51mA	27mA	35mA	19mA
Red Flash Flash Rouge Roter Blitz	24V	25mA	16mA	16mA	10mA
	48V	18mA	11mA	11mA	9mA

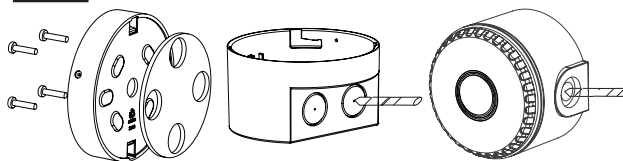
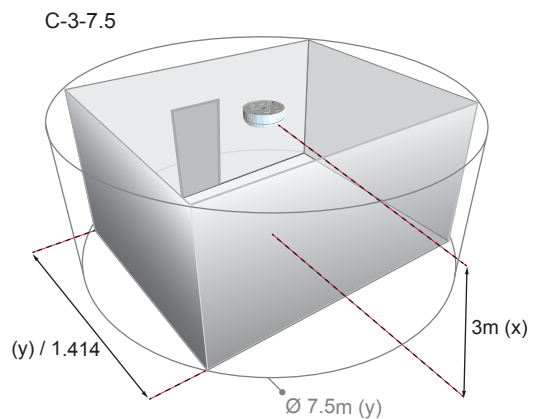

- (EN) Drilling diameter must be adjusted to the diameter of the cable glands.
- (FR) Le diamètre de perçage doit être adapté au diamètre des presses-étoupes.
- (DE) Bohrdurchmesser muss dem Kabeldurchmesser angepasst sein.
- (PL) Średnica wiercenia musi być dostosowana do średnicy dławików kablowych.
- (IT) È necessario adattare il diametro di perforazione in base al diametro del pressacavi.

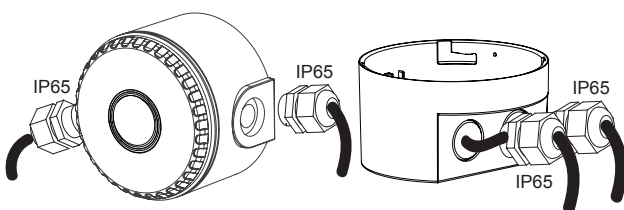

- (EN) Cable glands must be compatible with declared cable size.
- (FR) Les presses-étoupes doivent être adaptés à la section des câbles déclarée.
- (DE) Kabeldurchführungen müssen mit den angegebenen Kabelabmessungen kompatibel sein.
- (PL) Dławiki kablowe muszą pasować do zadeklarowanego rozmiaru kabla.
- (IT) È necessario che i pressacavi siano compatibili con la dimensione del cavo indicata.

# EATON

Powering Business Worldwide

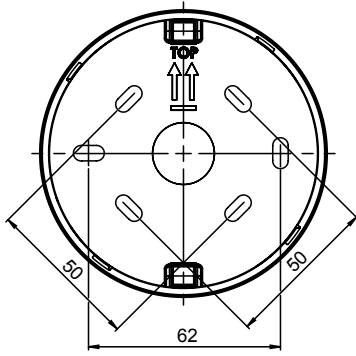

IP65

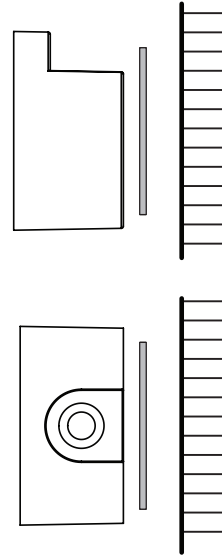
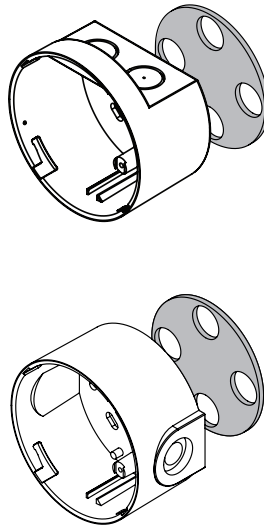

- (EN) Place gasket between the product and mounting surface.
- (FR) Placer le joint entre le produit et le support.
- (DE) Die Dichtung zwischen dem Produkt und der Befestigungsplatte.
- (PL) Umieścić uszczelkę między produktem a powierzchnią montażową.
- (IT) Posizionare guarnizione tra il prodotto e la superficie di montaggio.

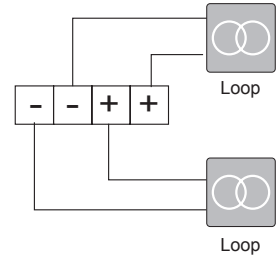
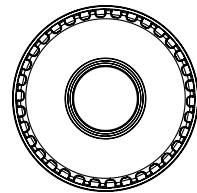
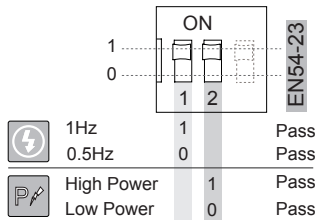

\* (EN) Product manual M12-005  
 \*\* (EN) POŻAR label must be applied if product used in Poland  
 (PL) Naklejka "POŻAR" musi być użyta jeżeli produkt jest stosowany w Polsce.

Essential Characteristics / Caractéristiques

Operational Reliability / Fiabilité de Fonctionnement	
Duration of operation / Durée de fonctionnement	PASS / CONFORME
Provision for external conductors / Disposition pour conducteurs extérieurs	PASS / CONFORME
Flammability of materials / Inflammabilité des matériaux	PASS / CONFORME
Enclosure protection / Indice de protection	PASS / CONFORME
Access / Accès	PASS / CONFORME
Manufacturer's adjustments / Réglages du fabricant	PASS / CONFORME
On-site adjustment of behaviour / Réglages du site	PASS / CONFORME
Requirements for software controlled devices / Exigences relatives aux dispositifs contrôlés par logiciel	PASS / CONFORME
Performance parameters under fire condition / Paramètres de performance en cas d'incendie	
Coverage Volume / Volume de couverture	PASS / CONFORME
Variation of light output / Variance de la puissance lumineuse	PASS / CONFORME
Minimum/maximum light intensity / Intensité lumineuse minimale/maximale	PASS / CONFORME
Light colour / Couleur de la lumière	WHITE / RED / BLANC / ROUGE
Light pattern & frequency of flashing / Effets temporels lumineux et fréquence de clignotement du flash	0.5/1Hz
Marking & Data / Marquage et données techniques	PASS / CONFORME
Synchronisation	PASS / CONFORME

Temperature Resistance / Résistance à la température	
Dry heat (operational) / Chaleur sèche (fonctionnel)	PASS / CONFORME
Dry heat (endurance) / Chaleur sèche (endurance)	PASS / CONFORME
Cold (operational) / Froid (fonctionnel)	PASS / CONFORME
Humidity Resistance / Résistance à l'humidité	
Damp heat, cyclic (operational) / Chaleur humide, cyclique (fonctionnel)	PASS / CONFORME
Damp heat, steady state (endurance) / Chaleur humide, continue (endurance)	PASS / CONFORME
Damp heat, cyclic (endurance) / Chaleur humide, cyclique (endurance)	PASS / CONFORME
Shock & Vibration & Resistance / Choc & Vibration & Resistance	
Shock (operational) / Choc mécanique (fonctionnel)	PASS / CONFORME
Impact (operational) / Impact (fonctionnel)	PASS / CONFORME
Vibration (operational) / Vibration (fonctionnel)	PASS / CONFORME
Vibration (endurance)	PASS / CONFORME
Corrosion Resistance / Résistance à la corrosion	
SO <sub>2</sub> corrosion (endurance) / Corrosion par le SO <sub>2</sub>	PASS / CONFORME
Electrical Stability / Stabilité électrique	
EMC immunity (operational) / CEM Immunité (fonctionnel)	PASS / CONFORME

Manufactured By  
**Eaton Electrical Products Ltd**  
 Llantarnam Park, Cwmbran, Gwent, NP44 3AW, UK  
 Tel: +44 (0)1633 628 500  
 Fax: +44 (0)1633 866 346

www.eaton.com  
 Made in the UK

**Eaton Industries Manufacturing GmbH**  
 Electrical Sector EMEA  
 Route de la Longeraie 7  
 1110 Morges, Switzerland  
 Eaton.eu

© 2017 Eaton All rights reserved March 2017