

ASSERTA Industrial Sounder (115Vac/230Vac)



Specification

	115Vac/230Vac 110dB(A)	115Vac/230Vac 120dB(A)
Operation	Continuous	Continuous
Operating Voltage Range	115Vac/230Vac 50/60Hz	115Vac/230Vac 50/60Hz
Sound Output @ 1m	See table overleaf	See table overleaf
Current Consumption	0-80mA@115Vac 0-40mA@230Vac	0-130mA@115Vac 0-65mA@230Vac
Maximum Power	9W	15W
Tones	42 see table overleaf	42 see table overleaf
Operating Temperature	-25°C to +75°C	-25°C to +75°C
Construction	ABS /PC Plastic Case	ABS /PC Plastic Case
Ingress Protection	IP66	IP66
Fuse	80mA Anti surge, 20mm	80mA Anti surge, 20mm

Dimensions

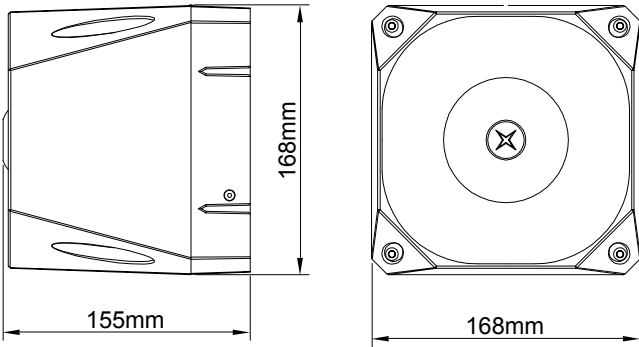

1. Installation

Knockout or drill required cable gland holes, and fix required cable glands.

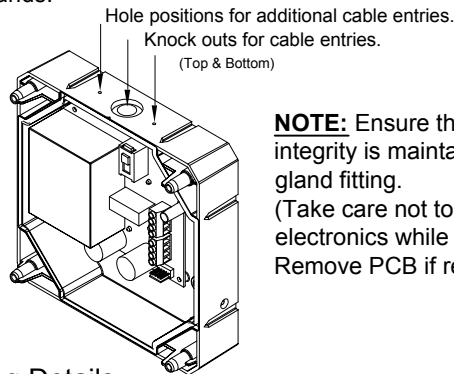

NOTE: Ensure that the IP integrity is maintained during gland fitting. (Take care not to disturb the electronics while drilling. Remove PCB if required)

2. Fixing Details

Fix base to wall in 4 positions.

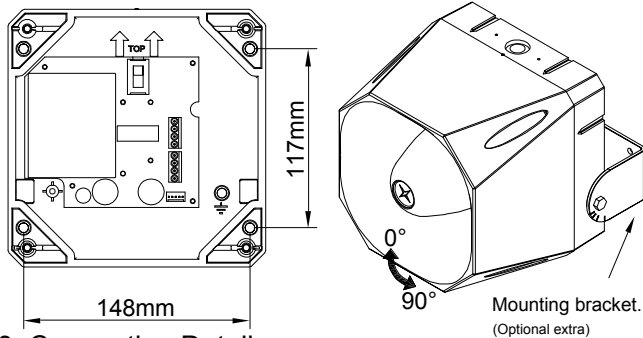

3. Connection Detail

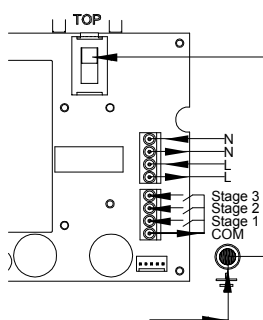

Set switch to correct requirement for installation. (115Vac or 230Vac)

NOTE: A readily accessible disconnect device must be incorporated in the mains supply wiring to this unit.

4. Sounder Settings

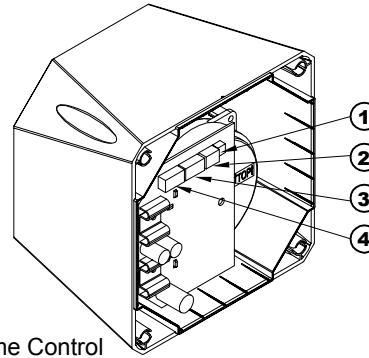

1. Volume Control

Turn dial clockwise to increase volume. (nominal 20dB Range)

2. Switch 1 (Time out setting)



BIT 123X	Minutes	BIT 123X	Minutes
111X	5	011X	25
110X	10	010X	30
101X	15	001X	40
100X	20	000X	∞

0 = Open
1 = Closed

Switch 1 bit 4 is to select voice (0)/ no voice (1). (Where fitted)

3. Switch 2 (Stage1 tone selection)

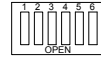

See table overleaf.

4. Switch 3 (Stage 2 tone selection)

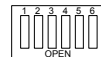

See table overleaf.

(Stage 3 Tone is dependent on the setting of switch 2)

5. Sounder Assembly

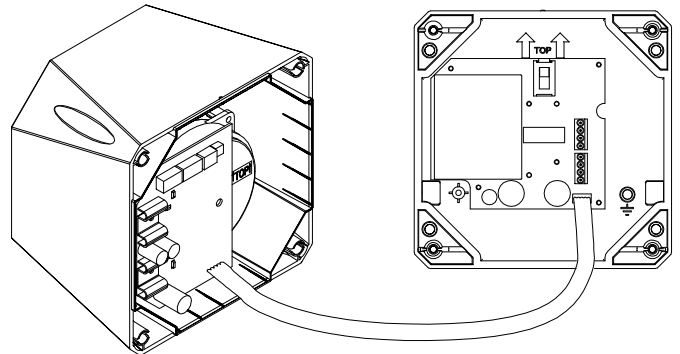

1. Plug the 5 way ribbon cable into the base header.
2. Ensure that the top indicator on the base is aligned with the top indicator on the sounder, and push the sounder onto the base.
3. Secure the sounder to the base using the bolts provided.

Ensure that guide ribs are aligned. (Top & Bottom)

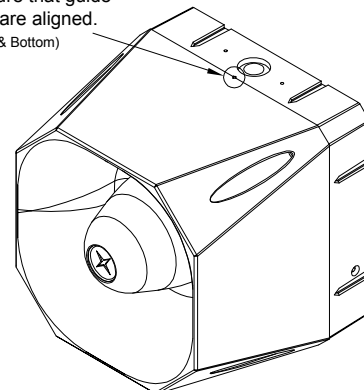

WARNING : On some tones the output level can exceed 120dB(A) @ 1m. Consult the relevant or appropriate health and safety regulations for guidelines. Tones Table overleaf.
Do not remove cover, refer servicing to qualified personnel.
High voltage present within this equipment.



NOTE : Polar dispersion information available in the technical manual. (Ref:M03-003)

Industrial Sounder Tones Table

No	CODE 123456	TONE			Use	Stage 1 & 2		STAGE 3
		Description	Frequencies	Pattern		115Vac/230Vac LP dB(A)@1m	115Vac/230Vac HP dB(A)@1m	
A1	111111	Alternating	800 & 970	2Hz (250ms-250ms)	111	120	A14	
A2	111110	Sweep	800 & 970	7Hz (7/s)	112	120	A14	
A3	111101	Sweep	800 & 970	1Hz (1/s)	112	120	A14	
A4	111100	Continuous	2850	Steady	106	111	A9	
A5	111011	Sweep	2400 to 2850	7Hz	103	109	A4	
A6	111010	Sweep	2400 to 2850	1Hz	105	110	A4	
A7	111001	Slow Whoop	500 to 1200	3s sweep, 0.5s silence, then repeat (rep)	111	119	A14	
A8	111000	Sweep	1200 to 500	1Hz	111	119	A14	
A9	110111	Alternating	2400 & 2850	2Hz (250ms-250ms)	108	113	A4	
A10	110110	Intermittent	970	0.5Hz (1s On/1s Off)	108	117	A14	
A11	110101	Alternating	800 & 970	1Hz (500ms-500ms)	109	118	A14	
A12	110100	Intermittent	2850	0.5Hz (1s On/1s Off)	107	112	A4	
A13	110011	Intermittent	970	0.8Hz (250ms On/1s Off)	108	117	A14	
A14	110010	Continuous	970	Steady	109	118	A8	
A15	110001	Alternating	554 & 440	100ms-400ms	106	115	A14	
A16	110000	Intermittent	660	3.3Hz (150ms On/150ms Off)	106	114	A14	
A17	101111	Intermittent	660	0.28Hz (1.8s On/1.8s Off)	106	115	A14	
A18	101110	Intermittent	660	0.05Hz (6.5s On/13s Off)	106	115	A14	
A19	101101	Continuous	660	Steady	107	116	A1	
A20	101100	Alternating	554 & 440	0.5Hz (1s On/1s Off)	106	115	A19	
A21	101011	Intermittent	660	1Hz (500ms-500ms)	106	115	A4	
A22	101010	Intermittent	2850	4Hz (150ms On/100ms Off)	105	110	A4	
A23	101001	Sweep	800 to 970	50Hz	109	117	A14	
A24	101000	Sweep	2400 to 2850	50Hz	106	110	A4	
A25	100111	Intermittent	970	3X500ms pulses followed by 1.5s silence then repeat	109	118	A14	
A26	100110	Intermittent	2850	3X500ms pulses followed by 1.5s silence then repeat	107	112	A4	
A27	100101	Continuous	4000	Steady	101	105	A6	
A28	100100	Alternating	800 & 970	2Hz (250ms-250ms)	109	118	A14	
A29	100011	Alternating	990 & 650	2Hz (250ms-250ms)(Symphoni tones)	109	117	A14	
A30	100010	Alternating	510 & 610	2Hz (250ms-250ms)(Squashni Micro tones)	107	116	A14	
A31	100001	Sweep	300 to 1200	1Hz	110	118	A14	
A32	100000	Continuous	Bell	Steady	111	117	A3	
A33	011111	Continuous	Bell	3X500ms pulses followed by 1.5s silence then repeat	111	117	A14	
A34	011110	Alternating	1000 & 2000	1Hz (500ms-500ms)	107	115	A4	
A35	011101	Intermittent	420	pulsed @ 0.625s	108	118	A14	
A36	011100	Sweep	500 to 1200	Sweep 3.75s followed by 0.25s gap	109	117	A14	
A37	011011	Sweep	1400 to 1600	Sweep up 1s, sweep down 0.5s	108	116	A14	
A38	011010	Sweep	500 to 1200	Sweep up & down over 3s	109	117	A14	
A39	011001	Intermittent	720	0.7s On, 0.3 Off	110	118	A14	
A40	011000	Sweep	422 to 775	Sweep for 0.85s, 1s delay, repeat	109	118	A14	
A41	010111	Continuous	470	Steady	104	114	A3	
A42	010110	Continuous	370	Steady	104	113	A3	