

FXP5000 series - Conventional control panel



“Contemporary and compact panel design that provides a solution to any conventional system requirement”

The FXP50016 conventional control panel is a 16 zone panel. The panel features an array of user friendly features. The attractive flush or surface mountable plastic enclosure, with metal back box, has been designed through intensive voice of the customer research to provide ample space for termination of cables.

The FXP50016 comes with a zonal relay card as standard allowing outputs to be switched on a by zone basis.

Features and benefits

- Zonal relay card as standard
- One man test facility
- Non latching zone feature
- Class change input
- Fire and fault relays
- Discreet enclosure
- Supplied complete with battery for 24 hour standby

FXP50016	
No. of zones	16
Detectors per zone	30
No. of alarm circuits	4
Zonal relay card	✓

Specifier's guide

4.2 Control panels and repeater panels

Technical specification

Code	FXP50016
Description	16 zone control panel
Standards	EN54 Pt2 1998, A1:2006, EN54 Pt4 1998, A1:2002 + A2:2006
Specification	
Number of zones	16
Detectors per zone	30
Number of alarm circuits	4
Alarm circuit load	400mA per circuit, 1.6A total
End of line devices	Detection circuits: EOLM-1 monitoring unit Alarm lines: 6.8K Ω resistor
Auxiliary fire signal/fault output	1A 24V dc single pole changeover contacts
Auxiliary dc output	50mA
Mains input voltage	230V ac -15% +10%
System operating voltage	24V dc
Standby duration	24 hours
Battery (sealed lead acid)	2 x 4Ah
Recharge period	24 hours
Environmental	
Operating temperature	-5°C to +40°C
Humidity (non condensing)	0 to 75% RH
Physical	
Construction	Polycarbonate housing & metal back box
Dimensions (H x W x D)	Surface: 276mm x 375mm x 136mm Cut-out: 232mm x 335mm x 96mm
Weight	6.8kg
Ingress protection	IP30
Cable entry	Top: 12x20mm entries with blanking plugs Rear cable entry aperture

Dimensions

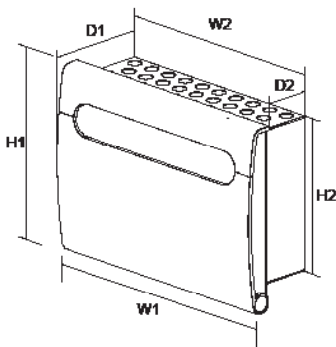

Description	H1 (mm)	W1 (mm)	D1 (mm)	H2 (mm)	W2 (mm)	D2 (mm)
	Total height	Total width	Total depth	Back box height	Back box width	Back box depth
16 Zone	276	375	136	232	335	96

System functionality

1. Normal and supervisor mode facility. Supervisor mode protected by 4 digit security code to prevent unauthorised use
2. Supervisor mode provides access to test mode, where a one shot weekly test facility can be initiated by the user. When in operation, the user has a period of time in which to put a call point into fire condition, after which the system automatically resets and returns to normal mode
3. Commissioning walk test feature permits the system to be easily tested after installation and prior to handover. The panel automatically resets and returns to normal operation after a detection device has been tested. Each device can then be tested in turn via the same procedure
4. Supervisor mode also provides facility to disable the following for maintenance or other purposes:
 - Each detection zone independently
 - The alarm circuits
5. Non-latching zone facility is available as standard and can be programmable via Dip switches located on the display board

Detection capacity

1. Up to 30 detectors per zone. End of line monitoring devices must be fitted and are supplied as standard.
2. Detector circuits are monitored for open circuit, short circuit and detector removal.

Alarm capacity

1. Four separate alarm lines - 400mA maximum load per line.
2. Alarm lines are monitored for open circuit and short circuit faults.

User interface

1. Stylish and compact panel with 6 touch button keypad control of all functions and LED indication
2. Simple one-shot weekly test with auto-reset facility
3. Comprehensive power, fire, and fault LED indicators and integral piezo buzzer for on-board fire or fault indication
4. Battery high/low voltage alarm facility
5. Log book storage facility in front panel

Interface options

1. Class change input facility. Terminals provided for switching of alarm circuits to indicate school/college class change
2. 2 x1A 24V DC relays for Fire and Fault are available for remote signalling
3. Auxiliary 24V DC output power supply provided as standard on all panels

Standard panel connections

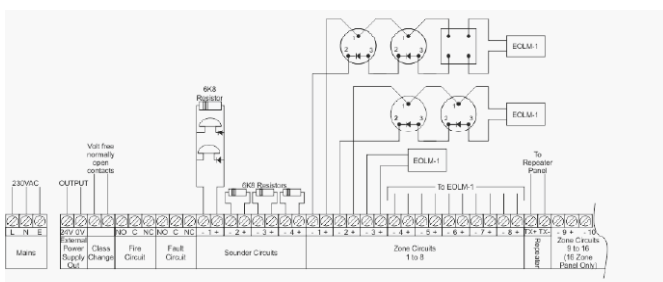

Catalogue numbers

Description	Code
16 zone control panel	FXP50016
Fire alarm system log book	MFALOG
16 zone panel no batteries	EFCV16Z(-NB)
1x12V 4ah sla butt MF200/400 battery	MB412