

Analogue addressable detector



Wiring hints

- Each terminal is suitable for clamping up to 2 wires
- Clamping of 2 wires of very different diameters under one screw is not recommended
- DO NOT USE A POWER TERMINAL DRIVER
- Suitable for mounting to mounting boxes with 50-80mm fixing centers

Utilising locking tab

The mounting base includes an optional feature to prevent the removal of the detector without a tool.

1. Remove the standard fit retaining clip
2. Insert the locking clip which is located at the center of the base as shown

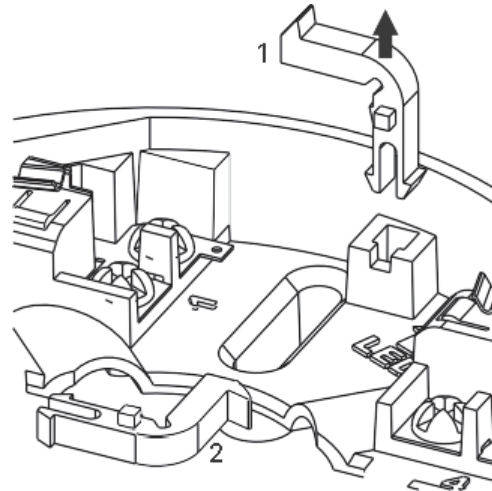

General

If difficulty is experienced when mounting the detector, this may be due to the following:

- wiring causing an obstruction - move or shorten wires
- Although the base is tolerant to uneven mounting surfaces, a very uneven surface may cause the base to deform when mounting screws are tightened down - loosen screws to reduce this or slide base to a flatter position

Mount the detector onto the base as described in detector installation (see over) and rotate fully clockwise until it finally clicks.

The detector is now locked into position, remove by utilising a suitable tool (e.g. a thin screw driver) into the hole in the detector cover. Gently push the tool into the detector and rotate anti-clockwise.

CAB300, MAB800, FXN720 specification

Supply Voltage	18-30 V DC
Cable Size	0.5 - 2.5mm ²
Mounting hole centers	50 - 80mm
Recommended cable types	FIRETUFF or FP200

Warning: do not use high voltage testers when detectors or control panel are connected to the system.

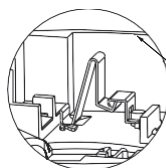
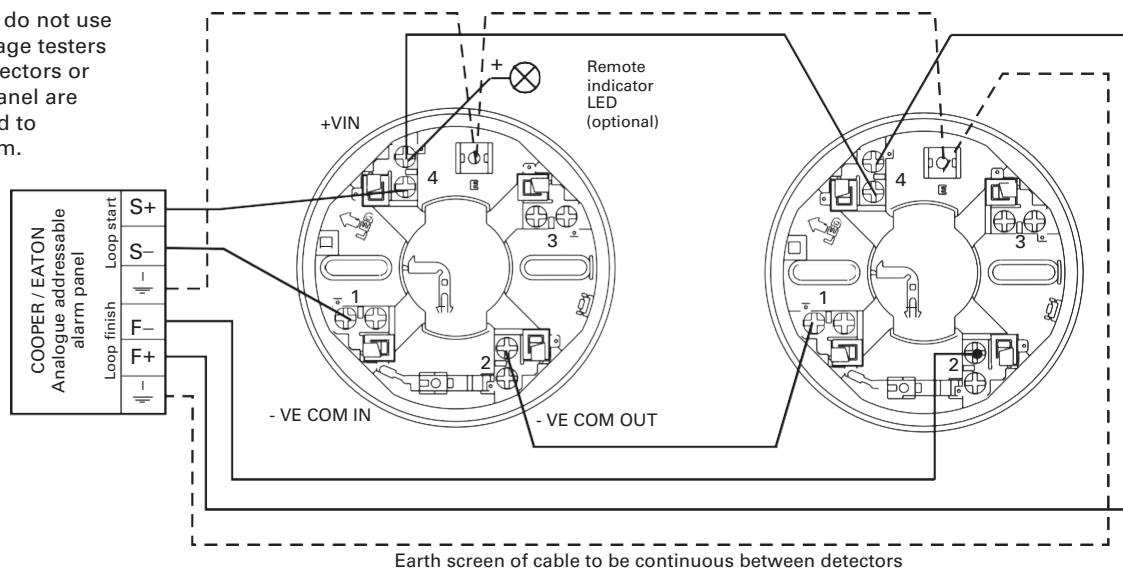

Attention: If using the outer connection on terminal 2, ensure the operation of the switch is not impeded and that there no shorts between terminal 2 and the switch contact.

Ensure that the cable does not short onto the contact

	MAP820 FXN723 CAP320	MAH830 FXN725 CAH330	MAOH850 FXN722 CAPT340
Analogue addressable Detector type	Photoelectric	Heat	Photo/Thermal
Operating voltage	18 to 30 Vdc	18 to 30 Vdc	18 to 30 Vdc
Standby current (max)	220µA	220µA	220µA
Alarm current (typ)	5mA	5mA	5mA
Ambient temperature (max)	60°C	A1R 50°C BS 65°C CS 80°C	50°C
Ambient temperature (min)	-10°C	-10°C	-10°C
Alarm temperature (static)	N/A	A1R 60°C BS 77°C CS 90°C	60°C
Heat detector class –as defined by EN54-5:2000	N/A	A1R, BS, CS Control panel selectable	A2S
Relative humidity (non-condensing)	0 to 95%	0 to 95%	0 to 95%
Height (without base)	34mm	43mm	43mm
Height (with base)	47mm	56mm	56mm
Diameter (Base)	104mm	104mm	104mm
Weight (without base)	78g	78g	78g
Material	PC/ABS	PC/ABS	PC/ABS
Colour	White	White	White

	Applicable standards	Declaration of performance
MAP820 FXN723 CAP320	EN54-7: 2000 +A1: 2002 +A2: 2006 EN54-17: 2005	DoP0157
MAH830 FXN725 CAH330	EN54-5: 2000 +A1: 2002 EN54-17: 2005	DoP0156
MAOH850 FXN722 CAPT340	EN54-7: 2000 +A1: 2002 +A2: 2006 EN54-5:2000 +A1: 2002 Class A2S EN54-17: 2005 CEA4021:2003	DoP0158

Short circuit isolation data (integral with each detector)

Total loop resistance for correct operation of short circuit isolator	80Ω (max)
Parallel fault resistance to be seen at the control panel for isolators to open	200Ω (typ)
Continuous current allowable through isolator	700mA (max)
Isolator resistance in closed state	0.26Ω (max)
Leakage current into direct short circuit with isolator open	14mA (max)
Voltage at which isolator changes from open to closed or closed to open state	3.8V to 11V
Maximum switching current of isolator	1.5A

Detector Installation

- Fit detector to mounting base and rotate clockwise until the detector drops into place
- Continue to rotate clockwise until the detector clicks and no further rotation is possible
- If the detectors are required to be locked into position, refer to the mounting base installation instructions (see over leaf)
- Smoke detectors are supplied fitted with dust covers for general protection against airborne contaminants. These must be removed from all detectors before the fire system is commissioned
- NB. These dust covers do not provide adequate protection against quantities of dust generated by building work, sanding etc. Therefore, detectors should not be installed until this type of work has been completed

Eaton
EMEA Headquarters
Route de la Longeraie 7
1110 Morges, Switzerland
Eaton.eu
TEL: +44 (0) 1302 321541
FAX: +44 (0) 1302 303220
Firesales@eaton.com
Firetechsupport@eaton.com

Eaton Electrical Systems Ltd.
Wheatley Hall Road, Doncaster,
South Yorkshire, DN2 4NB,
United Kingdom

Maintenance

Only minimal maintenance can be performed on this range of detectors as they do not contain any site serviceable parts. The frequency of maintenance will depend on the environment to which the detector is exposed but should be at least annually. Dusty or damp environments will demand more frequent maintenance.

- Remove the detector from its mounting base
- Use a vacuum cleaner to remove dust build up from around the smoke entry apertures of a smoke detector, or from around the heat sensing element of a heat detector
- For smoke detectors, visually inspect the insect mesh for blockages. If these can not be cleared by vacuuming, the detector must be replaced
- Re-fit detector to its mounting base and test as described above
- Detectors that fail the testing procedure must be replaced

Each of the detectors in his range contain an integral short circuit isolator, which operates between the -VE COM IN terminal and the -VE COM OUT terminal (terminals 1 & 2; see base wiring diagram overleaf). The isolator operates in conjunction with a compatible addressable control panel when a low parallel resistance fault of typically 200Ω is presented between the +VE and -VE of the loop wiring.

Testing

All detectors must be tested following installation or routine service and maintenance. It is recommended that these tests are carried out by a competent person. Authorised personnel must be informed that the fire system will be temporarily out of service before commencing testing. To prevent unwanted alarms, ensure that the control panel is in the 'One Man Walk Test' mode. When all tests are complete, re-enable the previously disabled zones and notify authorised personnel that the system is operational.

Smoke Detectors; Photo/Thermal Detector

- Subject the detector to be tested to a controlled amount of an approved synthetic smoke aerosol via a smoke detector test pole. Suitable products are available for example, from No Climb Products Ltd
- Check that the red LED on the detector lights within 30 seconds and the appropriate alarm address indication is displayed on the control panel. If an optional remote LED is fitted, check that this also lights
- Ensure that the control panel activates into alarm
- The control panel will automatically reset after a few seconds
- This procedure will test the smoke sensing circuitry of the Photo/Thermal Detector

Heat Detectors; Photo/Thermal Detector

- Using a heat gun or hair dryer capable of generating temperatures of up to 95°C, direct the heat source towards the heat sensing elements, visible through the side of the outer cover, from a distance of 15 to 30cm. Care should be taken not to allow the plastic surface temperature to exceed 110°C otherwise damage may occur
- When the temperature reaches the 'Alarm Temperature' (see Specifications above), check that the red LED on the detector lights and the appropriate alarm address indication is displayed on the control panel. If an optional remote LED is fitted, check that this also lights
- Ensure that the control panel activates into alarm
- The control panel will automatically reset after a few seconds
- This procedure will test the heat sensing circuitry of the Photo/Thermal Detector