

Diesel Engine Fire Pump Controllers Battery Charger Replacement Instructions

The instructions outline the steps required to retrofit existing FD100/FD110 Diesel Engine Controller Battery Chargers with retrofit kit # 4A55541G01.

***WARNING* Only qualified personnel should complete this procedure.**

1. Disconnect the AC and DC power from the fire pump controller.
2. Remove the wires marked C, A, +, -, L, N from the battery charger terminals.
3. Remove the crimp-on connector from each wire and strip the end of each wire so that it can be inserted into the appropriate terminal block on the charger retrofit back pan.
4. Remove the existing battery charger(s) and install the charger retrofit kit(s).
5. Re-ground the ground wires attached to the old charger - to the ground lug located to the right of the terminal blocks of the retrofit kit.
6. Insert the wires into the appropriate terminals located at the bottom of the retrofit kit.

Existing Battery Chargers

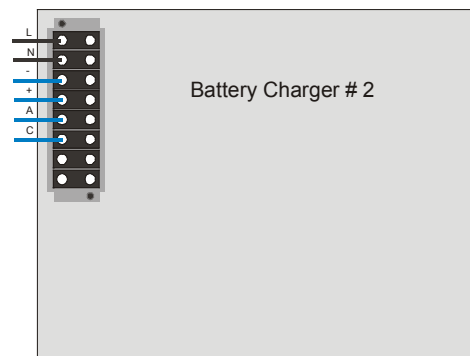
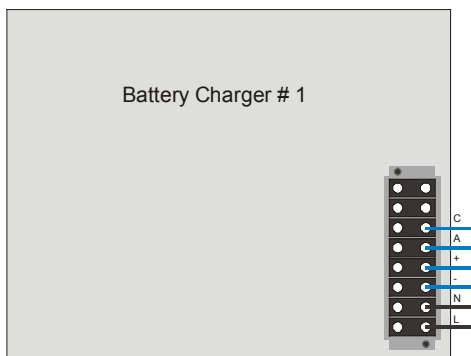

Battery Charger Retrofit Kit

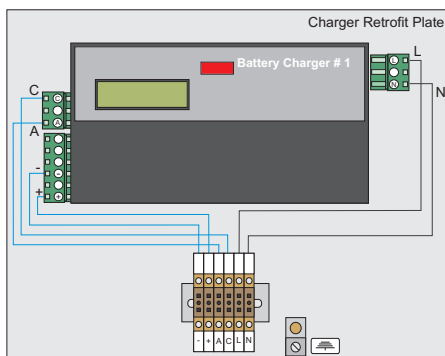

↑
Insert wires from the existing charger into the terminals at the bottom of the retrofit plate.

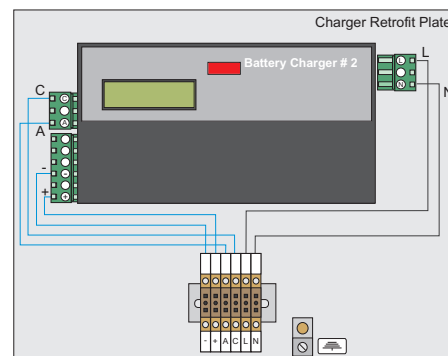

↑
Insert wires from the existing charger into the terminals at the bottom of the retrofit plate.

Eaton Industries Canada
Fire Pump Controllers
10725 25th Street NE #124
Calgary, AB T3N0a4
www.chfire.com

© 2013 Eaton
All Rights Reserved
Printed in Canada
Publication No. PU05805032K/H
October 2013