

- 1 - DIESEL PLUS MEMBRANE
- 2 - LOCKABLE HANDLE
- 3 - HAND OFF AUTO SELECTOR SWITCH
- 4 - STOP BUTTON
- 5 - CRANK BUTTONS
- 6 - AUDIBLE ALARM
- 7 - DC FAIL LIGHT
- 8 - DISCHARGE 1/4" NPT - FEMALE
- 9 - SENSING LINE 1/2" NPT - FEMALE
- 10 - ALLOWABLE CABLE ENTRY/EXIT AREA

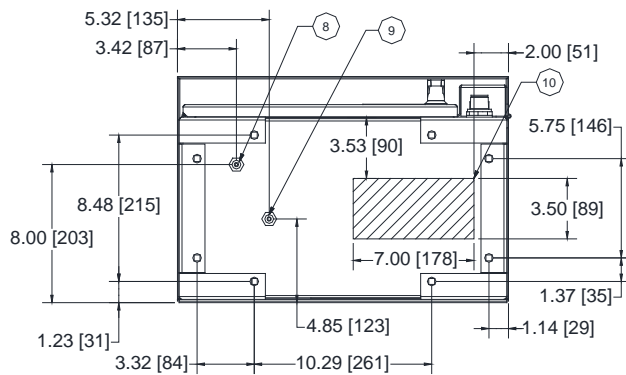

Approximate Weight

Lbs.	(Kg)
105	(48)

NOTES:

- 1. All enclosures finished in FirePump red.
- 2. Cable Entrance bottom only.
- 3. Standard Enclosure type NEMA 2
- 4. Enclosure made from #14 Gauge (0.75) HR Steel.
- 5. Feet are removable.

* NEMA 4, 4X enclosures are supplied:
 With 1/4 Turn latches instead of a standard handle.