

JOCKEY
Touch™

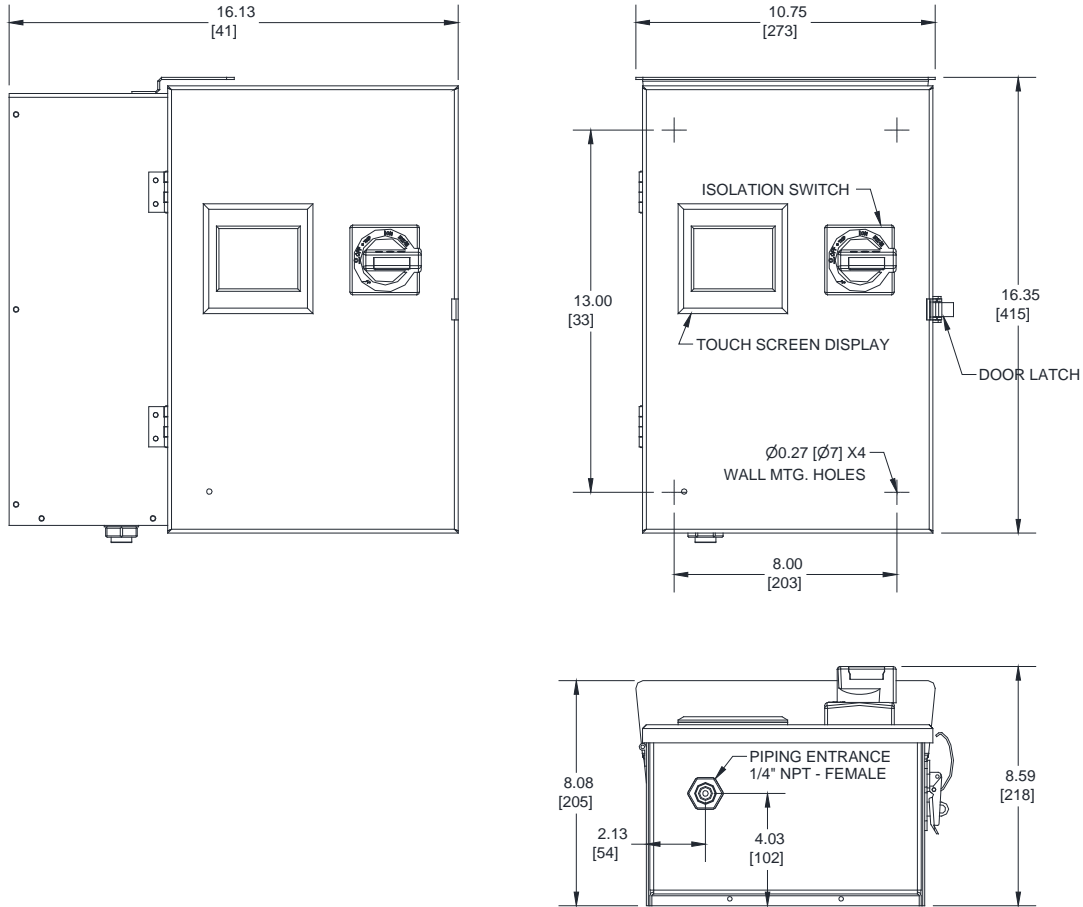

200-208V		220-240V		380-415V		440-480V		550-600V	
Motor Hp	Withstand Rating (kA)	Motor Hp	Withstand Rating (kA)	Motor Hp	Withstand Rating (kA)	Motor Hp	Withstand Rating (kA)	Motor Hp	Withstand Rating (kA)
0.33 - 0.75	50	0.33 - 0.75	50	0.33 - 1.5	50	0.33 - 2	50	0.33 - 7.5	50
1 - 2	65	1 - 3	65	2 - 5	65	3 - 5	65	10 - 30	10 *
3 - 4	42	4 - 5	42	7.5	42	7.5 - 10	42		
5 - 10	18	7.5 - 10	18	10 - 15	18	15 - 20	18		

120V 1ph		208V 1ph		240V 1ph		Approx. Weight
Motor Hp	Withstand Rating (kA)	Motor Hp	Withstand Rating (kA)	Motor Hp	Withstand Rating (kA)	Lbs (Kg)
0.33 - 0.5	65	0.33 - 1	65	0.33	50	18 (8)
0.75 - 1	42	1.5 - 2	42	0.5 - 1.5	65	
1.5 - 2	18	3 - 4	18	2	42	
				3 - 5	18	

- NOTES:
- * Upstream circuit breaker required to maintain kA rating.
 - All enclosures finished in FirePump red.
 - Cable Entrance either top or bottom.
 - Standard Enclosure type NEMA 2