

Dimensions

Standard Enclosure - Type NEMA 2, 3R, 12

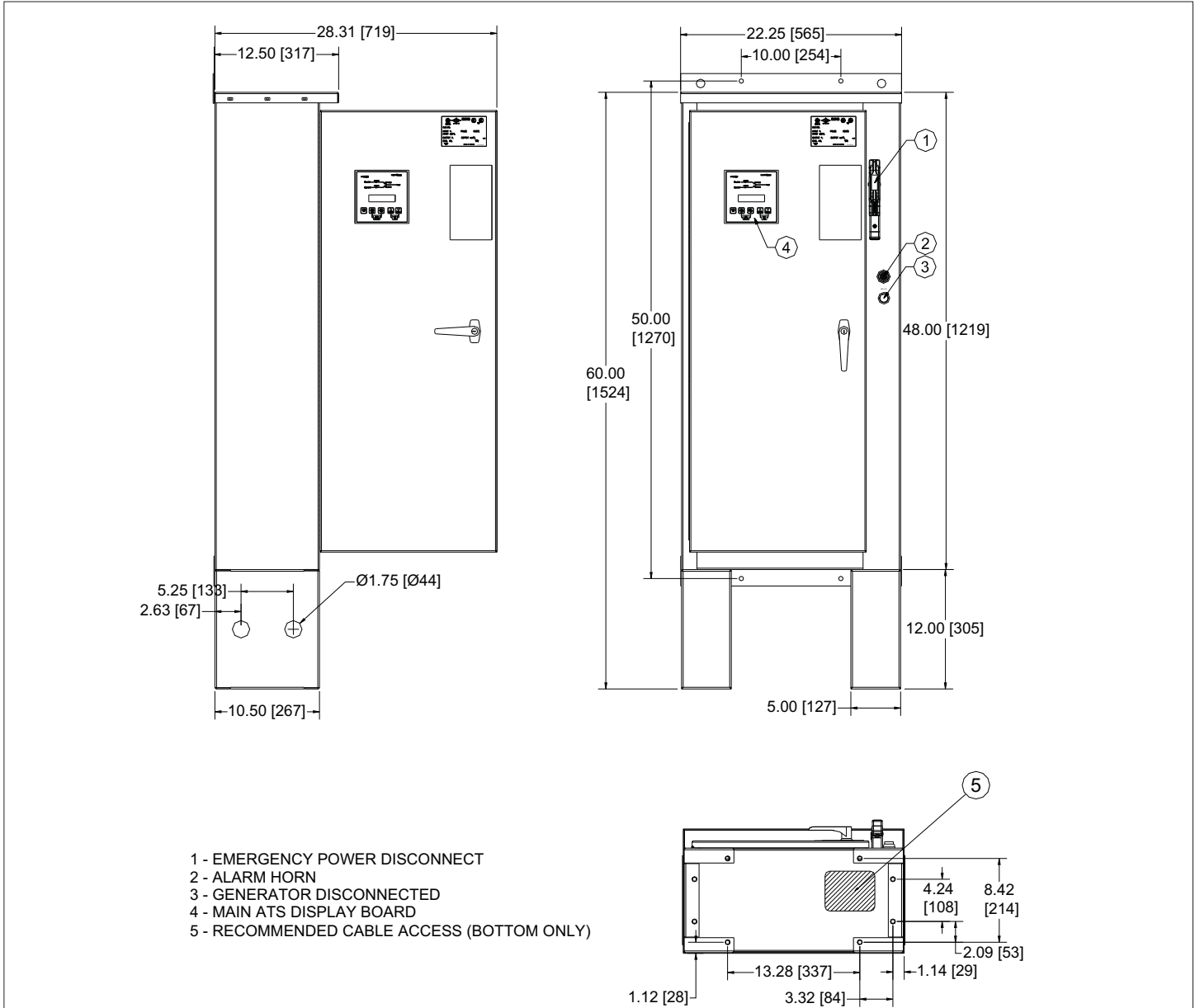

Dimensions in inches and [millimeters].

Motor Hp	Line Voltage	Withstand Rating			Approx. Weight Lbs. (Kg)
		Standard	Intermediate	High	
5 - 40	200 - 208V	100,000	Consult Factory	Consult Factory	180 (81)
5 - 50	220 - 240V				
5 - 75	380 - 415V	65,000			
5 - 100	440 - 480V				
5 - 100	550 - 600V	25,000			



N. Y. C.
APPROVED



NOTES:

1. All enclosures finished in FirePump red.
2. Cable Entrance bottom only.
3. Standard Enclosure type NEMA 2.