

## Instructions for Eaton Cutler-Hammer Pump Controllers





**Table of Contents**

1. INSTALLATION AND MOUNTING OF PUMP CONTROLLER ..... 1

2. SYSTEMS OVERVIEW ..... 1

    2.4.1 Pressure Transducer Systems ..... 1

    2.4.2 Pressure Tank Systems ..... 1

    2.4.3 Flow Based Systems ..... 1

3. ELECTRICAL CONNECTIONS ..... 1

    3.1 General ..... 1

    3.2 Wire Sizes ..... 2

    3.3 Power Wiring ..... 2

    3.4 Control Transformer ..... 2

    3.5 Power ON Light ..... 3

    3.6 Electrical Checkout Instructions ..... 3

    3.7 Main Isolation Switch & Breaker ..... 2

    3.8 Contactor(s) ..... 2

    3.9 Incoming Connections ..... 2

4. OPERATION OF THE CONTROLLER ..... 2

    4.1 Pump Running ..... 2

    4.2 Control Selector Switch ..... 2

        4.2.1 OFF (Safety) Position ..... 2

        4.2.2 HAND (Manual) Position ..... 2

        4.2.3 AUTO (Automatic Control) Position ..... 3

    4.3 Automatic PLC Control ..... 3

        4.3.1 General ..... 3

        4.3.2 Low Suction Pressure ..... 3

        4.3.3 Alternation ..... 3

        4.3.4 Minimum Run Timer ..... 3

        4.3.5 Restart Delay Timer ..... 3

        4.3.6 Alternation Times ..... 3

        4.3.7 Alternator Overlap Time ..... 3

5. CONTROLLER SETUP AND ADJUSTMENTS ..... 3

    5.1 Pressure Switch Setting Instructions ..... 3

    5.2 Timer Setting Instructions ..... 4

6. OPTIONS ..... 4

    6.1.1 General ..... 4

    6.1.2 Audible Alarm / Silence Pushbutton ..... 4

    6.1.3 Weekly Clock ..... 4

    6.1.4 Phase Reversal ..... 4

    6.1.5 Phase Failure ..... 4

    6.1.6 Lightning Arrestor ..... 4

    6.1.7 Mercoid Pressure Switch ..... 4

    6.1.8 Low Suction Pressure Switch ..... 4

    6.1.9 Pressure Transducer ..... 4

    6.1.10 Space Heater ..... 4

        6.1.10.1 Space Heater with Thermostat ..... 4

        6.1.10.2 Space Heater with Humidistat ..... 4

    6.1.11 Sequential Start ..... 5

    6.1.12 Strobe Light ..... 5

    6.1.13 Starter Overload ..... 5

    6.1.14 Elapsed Time Meter ..... 5

    6.1.15 Run Period Timer ..... 5

    6.1.16 Low Suction Shutdown ..... 5

7. SERVICE & SUPPORT ..... 5

    7.1 Factory Location ..... 5

    7.2 Territory Assigned ..... 5

7.3 Quotations ..... 5

7.4 Email ..... 5

7.5 Flexible Production Capabilities ..... 5

7.6 Testing ..... 5

7.7 Local Representation ..... 5

7.8 Start Up ..... 5

7.9 Spare Parts ..... 5

FIGURE 1: TYPICAL DIMENSION DRAWING..... 6

FIGURE 2: TYPICAL WIRING SCHEMATIC DRAWING - PLC Based Controller ..... 7

## INSTALLATION & MAINTENANCE MANUAL FOR PUMP CONTROLLERS

In order to familiarize yourself with the Pump Controllers, please read the instruction manual thoroughly and carefully.

### 1. Installation and Mounting of Pump Controller

#### 1.1 General

Carefully unpack the controller and inspect thoroughly. Remove any packing materials within the controller.

Locate the pressure switch adjustment dial within the supplied materials, and install in accordance with the pressure switch instructions.

#### 1.2 Mounting

The controller should be located as close as is practical to the motor it controls and within sight of the electric motor, preferably ten feet or less.

The controller can be either wall or floor mounted depending on the style of controller required. The controller is not free standing and should be mounted with feet or bolted securely to a wall

Mount the enclosure in an area free from spraying or dripping water.

Ensure there is adequate access to all interior and exterior installed components (pressure switches).

Dimensions and weight vary by type of controller. Contact factory for specific information.

#### 1.3 Plumbing (Pressure Sensing Controllers)

If the controller is supplied as part of a package system, the pressure sensing lines are generally pre-installed on the package.

The controller is provided with a 1/4" NPT female system pressure connection located on the bottom, external side of the enclosure.

**NOTE:** Water lines to the pressure switch must be free from dirt and contamination.

## 2. Systems Overview

### 2.1 Relay Based Systems

Relay based systems are pressure based, however, instead of utilizing a PLC, general purpose relays, timers and an alternating relay are used to provide the control logic in the controller. The operation of single (simplex) or multiple (duplex, triplex, quadruplex) pumps is possible.

### 2.2 Current Sensing Systems

One or more current sensing relays are used to provide a signal to a PLC in the controller. The relays sense the current draw on each motor in the system. Once a pre-set value is reached, the controller will start a second pump. Once the current drops below a set value, the controller will shut down the second pump.

### 2.3 Pressure Sensing Systems

In a pressure sensing system, a pressure switch is used to provide a signal to a PLC within the pump controller. The controller responds to the input (system pressure) provided by the pressure switch to control the pump(s).

### 2.4 Optional Systems

#### 2.4.1 Pressure Transducer Systems

In a pressure transducer system, a pressure transducer is used in place of a standard pressure switch. The transducer provides an electronic input to the PLC, which results in a more precise operating system.

#### 2.4.2 Pressure Tank Systems

In a pressure tank system, an optional pressure tank is used to provide supplemental pressure to the pressure regulating valve(s). A pressure switch is normally used to provide a signal to the controller if the pressure in the tank drops below a pre-set value. Once received, the controller will provide a signal which is used to actuate a pump, which maintains the tank pressure above the system pressure. Once the pre-set pressure is restored, the controller stops the last pump started after a minimum run time.

#### 2.4.3 Flow Based Systems

A flow meter or flow switch, which monitors flow rather than pressure, is used in place of either a pressure switch or transducer. Once the flow in a pump nears its rated maximum flow, a second pump is started to supply the system demand flow. Once the flow drops below a set value, the controller will shut down the second pump.

## 3. Electrical Connections

**NOTE:** Ensure incoming conduit and connections are suitable for the controller enclosure rating.

### 3.1 General

All electrical connections should meet national and local electrical codes and standards.

The controller should be located or so protected that it will not be damaged by water escaping from pumps or pump connections.

Prior to starting, verify all data on the nameplate such as, catalog number, AC line voltage, horsepower and frequency. Also check all wiring connections and system pressure.

### 3.2 Wire Sizes

For control wiring, use wire sized according to NEC requirements.

### 3.3 Power Wiring

Connect the incoming power lines to the top of the circuit breaker ensuring the correct cable size is installed.

### 3.4 Control Transformer

The control power is supplied by a control power transformer (TR) which is protected by two fuses on the primary lines. Secondary power is 120Vac – 50 / 60Hz and is used to power internal components and indicating devices.

On pressure transducer controllers, the transducer and PLC are powered by a 120V / 24Vdc power supply.

### 3.5 Power ON / Pump Run Lights

Optional 120V Power On and Pump Run lights are available which indicate when the power is being supplied to the internal components and indicating devices and when the pump(s) are running.

In a PLC operated controller, these lights are included.

### 3.6 Electrical Checkout Instructions

*WARNING: The following procedures should be carried out by a qualified electrician familiar with the electrical safety procedures associated with this product and its' associated equipment.*

3.6.1 Overload Relay Trip Setting: The trip setting must be set as per the full load amps of the pump motor.

3.6.2 Circuit Breaker Setting: Factory set. Do not adjust.

### 3.7 Main Isolating Switch/Circuit Breaker

The main isolating switch (MIS) is intended for isolating an electric circuit from its source of power. It has no interrupting rating and must be externally operable.

The circuit breaker (CB) is used to disconnect a running pump motor, if necessary. The CB also provides short circuit protection for the controller and the pump motor. In case of a short circuit the CB will trip instantaneously.

When necessary, a current limiter attachment may be mounted on the bottom of the CB to increase the interrupting capacity.

If one or more of the current limiter fuses blows, then the cause must be repaired immediately and new current limiters installed when repairs are complete.

The MIS is operated and interlocked with a single, externally mounted handle. The operator is interlocked so that the enclosure door cannot be opened with the handle in the ON position, except by qualified electrical personnel by use of a defeater screw located on the side of the operator handle.

### 3.8 Contactor(s)

The contactor(s) [M1, M2 and M3] connect(s) the pump motor to the supply, under the control of the PLC.

The contactor coil(s) are connected to the 120V control voltage of the controller, and should be ordered accordingly if a replacement coil is ever required.

### 3.9 Incoming Connections

The complete schematic showing incoming breakers and contactor(s), is shipped with each Pump Controller and will vary depending upon the application.  
*Refer to Figure 2, page 9 for a typical example.*

Inspect all electrical connections, components and wiring for any visible damage and correct as necessary. Ensure that all electrical connections are tightened before energization.

Refer to the appropriate wiring schematic drawing included in this manual (page 9), and/or affixed to the enclosure door, for all wiring information pertaining to the incoming AC power supply and motor wiring.

Install necessary conduit using proper methods and tools. Ensure all debris and metal chips are completely removed from the controller and components.

Incoming AC line voltage is clearly marked L1, L2, L3 and ground, located at the top of the breaker.

## 4. Operation of the Controller

### 4.1 Pump Running

An auxiliary contact from the motor contactor(s) provides a signal to indicate that the pump is running.

In a PLC operated controller, the auxiliary contact is factory connected to the PLC. Upon detecting a contact closure, the PLC will provide a signal which will illuminate the Pump Run Light(s) on the front of the controller.

### 4.2 Control Selector Switch

A control selector switch labeled “Hand-Off-Auto” is provided on the front of each controller for each pump motor.

#### 4.2.1 OFF (Safety) Position

When the OFF position is selected, the motor contactor is de-energized and prevents the motor from running.

#### 4.2.2 HAND (Manual Control) Position

When the HAND position is selected, the pressure switch and/or pressure transducer as well as all automatic control is bypassed. The respective motor contactor is energized immediately upon selecting this position.

#### 4.2.3 AUTO (Automatic Control) Position

When the AUTO position is selected, the PLC in the pump controller automatically reacts to the starting conditions provided by the pressure input(s).

### 4.3 Automatic PLC Control

#### 4.3.1 General

When the AUTO position is selected, the PLC operates the pump controller. An internally stored program is used to control the pump controller components. Timer values are factory set, and can be field modified as per the controller manufacturers instructions.

#### 4.3.2 Low Suction Pressure

When the low suction pressure switch senses low suction pressure, a signal is provided which removes power to the commons of the PLC outputs, which shuts off all output components such as the control selector switch(es) and indicating lights.

As well, a signal is provided to the PLC which activates an override function within the PLC. The override function takes precedence over any inputs received and the PLC ignores the inputs.

At the same time, a low suction signal light is activated. The alarm signal light remains on until the low suction condition is no longer present and the pressure switch resets. The alarm circuit is automatically reset and will activate on the next instance of low suction pressure.

#### 4.3.3 Alternation

An alternation circuit is programmed into the PLC internal program according to system requirements.

In a duplex system where there is a small and large pump, the small pump is considered to be the lead pump and the large pump – the lag pump.

If all pumps are the same size, the controller can be set up to alternate which pump is set up as the lead pump and which pump(s) are set up as the lag pump(s).

#### 4.3.4 Minimum Run Timer

A minimum run timer is programmed into the PLC. The purpose is to ensure the pump motor is not subjected to frequent starts in response to pressure fluctuations. The time range is factory set at one minute. It can be field modified by following the PLC manufacturers' instructions.

#### 4.3.5 Restart Delay Timer

The restart delay timer is used to prevent starting a pump that is still slowing down from when it was last operating and the demand is less than is needed for the pump, but more than can be supplied by other pumps in the system. When the pump shuts down, the pressure can drop quickly enough to immediately signal the pump to start again. If the pump is still spinning, this can cause mechanical shock to the pump and motor. The restart delay allows the pump motor to slow sufficiently to be restarted safely.

#### 4.3.6 Alternation Times

The alternation time is the elapsed time required before the PLC switches the lead pump to a lag pump. The PLC utilizes an internal time clock and is factory set as per system requirements.

#### 4.3.7 Alternator Overlap Time

In a multiple pump application the overlap time is set so there is a delay before the first pump is shut down – to allow the second pump to come up to full speed. This helps to avoid any momentary pressure drop in the system.

### 5. Controller Setup and Adjustments

**WARNING:** The following procedures should be carried out by qualified personnel only.

#### 5.1 Pressure Switch Setting Instructions

Before attempting to set the pressure switch, de-energize the Pump Controller by opening the Circuit Breaker. This is done for safety, and so that the pump will not start and interfere with the adjustment procedure.

5.1.1 Set the differential adjustment on the pressure switch to minimum by turning the Differential Adjusting Screw fully counter clockwise. Set the operating pressure to well below the required pump starting pressure. Turn the Range Adjusting Screw clockwise to reduce the pressure and observe the scale on the switch.

5.1.2 Bleed the system until the pressure is reduced to the required pump starting pressure.

5.1.3 Slowly rotate the Range Adjusting Screw counter clockwise until a click is heard from the pressure switch. The switch is now set to the required pump starting pressure.

5.1.4 If it is necessary to re-adjust the differential, the operating pressure of the switch will also be changed and should be reset.

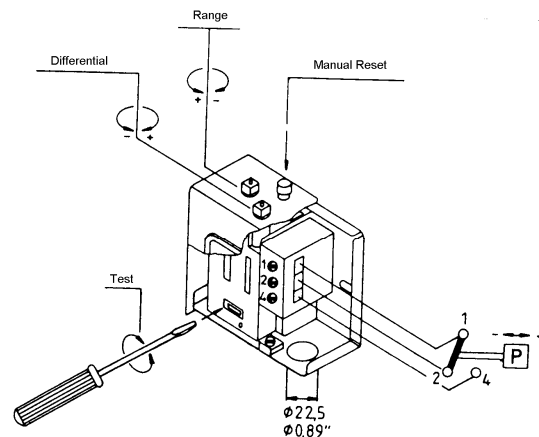

**NOTE:** The cut-in (start point) pressure is the cut-out (range adjusting setting) pressure minus the differential setting.

## 5.2 Timer Setting Instructions

To change timer set values, follow the steps below:

- Press the “OK” key to access the PLC menu.
- Highlight “PARAMETER” and press “OK”
- (The cursor should be blinking on timer – T1)
- Pressing the Up / Down arrows allows access to other timers.
- When you have found the timer you wish to change - it will display the factory set time.
- Pressing the Left Arrow or Right Arrow key will allow values in the hours or minutes to be changed.
- Use the Up / Down arrows to change the timer value.
- Press the “OK” key to save the changed timer value.
- (Pressing the ESC key before the “OK” key, will exit the programming mode without saving the timer values).
- Press the ESC key twice to exit the Programming mode.

## 6. Options

### 6.1.1 General

All Pump Controllers are available with a wide variety of options. Several of the most common ones are explained in the balance of Section 6.

Since the pump controllers incorporate a PLC, many more options than are included here, can be programmed and installed. Contact the factory for possible options not listed in this manual.

### 6.1.2 Audible Alarm / Silence Pushbutton

An optional audible alarm can be provided that will operate when the controller senses a low suction pressure condition, or other alarm conditions.

As well, an optional silence pushbutton can be provided that will silence the audible alarm. The alarm signal light remains on until the alarm condition is no longer present and the pressure switch resets.

### 6.1.3 Weekly Test

The weekly clock function can be provided by either a separate component or as part of the PLC program / function. This allows the user to set automatic time intervals for performing system tests.

### 6.1.4 Phase Reversal

The phase reversal relay provides a signal for indication of phase reversal. When the phase sequence is correct, the LED indicator on the phase reversal relay is OFF.

If there is a phase reversal, the relay changes to the “ON” state, the relay contacts operate, and a red indicating light on the front of the relay becomes illuminated.

### 6.1.5 Phase Failure

The phase failure relay provides a signal for indication of phase failure. When all phases are present, the relay is energized. If any phase fails, the relay will be de-energized and provide a phase failure signal.

### 6.1.6 Lightning Arrestor

A three phase, three-pole arrestor can be installed to protect all three phases from the damaging effects of transient surges from various sources such as utility switching, electric motor cycling etc.

### 6.1.7 Mercoird Pressure Switch

An optional Mercoird Pressure Switch may be used in place of the standard diaphragm pressure switch. Available models include a 10-300 psi and 25-600 psi switch.

### 6.1.8 Low Suction Pressure Switch / Shutdown

A 120V, 90-450 psi low suction pressure switch can be provided which senses low suction pressure, and shuts down the controller.

In a PLC based controller, the signal removes power to the commons of the PLC outputs, which shuts off all output components such as the control selector switch(es) and indicating lights.

As well, a signal is provided to the PLC which activates an override function within the PLC. The override function takes precedence over any inputs received and the PLC ignores the inputs.

At the same time, a low suction signal light is activated. The alarm signal light remains on until the low suction condition is no longer present and the pressure switch resets. The alarm circuit is automatically reset and will activate on the next instance of low suction pressure.

### 6.1.9 Pressure Transducer

In a pressure transducer system, a pressure transducer is used in place of a standard pressure switch. The transducer provides a 0.5 - 5.5V input to the PLC, which results in a more precise operating system.

### 6.1.10 Space Heater

An optional 120 / 220V, 300W space heater can be provided to keep the pump controller components at operating temperature.

#### 6.1.10.1 Space Heater with Thermostat

A space heater complete with thermostat can be provided to regulate the temperature in the controller. The thermostat operates based on a user selectable set point.

#### 6.1.10.2 Space Heater with Humidistat

A space heater complete with humidistat can be provided to control the elimination of moisture. The humidistat operates based on a user selectable set point.



### **6.1.11 Sequential Start**

A Sequential Start Timer can be programmed into the pump controller PLC for all multiple pump controllers.

The sequential start timer (SST) delays the starting of a pump in response to the input from a pressure switch or transducer.

If the lead pump restores the pressure in less than the time delay(s) applied to the lag pump(s), then the lag pump(s) will not start.

The SST can be programmed from 0 – 300 seconds. Typically, each pump should be delayed by 5-10 seconds

### **6.1.12 Strobe Light**

A compact, rotating warning light can be provided in place of an alarm bell for alarm indication purposes. It features a parabolic reflector which rotates around an incandescent lamp, providing 60 flashes per minute in all directions.

### **6.1.13 Starter Overload**

The pump controller PLC can be programmed to provide a set of contacts that will energize when an overload signal is received from the starter overload auxiliary contact. Additionally a set of DPDT contacts and / or an indicating light can be added to the controller.

### **6.1.14 Elapsed Time Meter**

A six digit LCD, solid state, non-resettable elapsed time meter can be installed which will record the amount of time the pump motor has been running. It receives the elapsed time signal from the auxiliary contact of the motor starter. This ensures that elapsed time is recorded in both the HAND and AUTO position of the H.O.A. control selector switch.

In a PLC operated controller, the elapsed time meter is integral to the PLC.

### **6.1.15 Run Period Timer**

The purpose of the Run Period Timer (RPT) is to ensure that the pump motor is not subjected to frequent starts in response to fluctuations in pressure.

In a PLC based controller, an RPT is programmed for each pump motor. The RPT run time is factory set to 1 minute. The RPT run time value(s) can be modified by following the Timer Setting Instructions.

### **6.1.16 Common Alarm Indication**

A common alarm indicating light can be provided which will activate when any alarm condition exists.

## **7.0 Service & Support**

### **7.1 Factory Location**

The Eaton Cutler-Hammer Pump Controller support team is located in our Pump Controller manufacturing facility, which allows for improved communication and a reduction in errors and delays.

### **7.2 Territory Assigned**

Each technical support Product Specialist is assigned to a specific territory to ensure continuity of efforts.

### **7.3 Quotations**

All requests for quotes are reviewed and processed within 48 hours of receipt.

### **7.4 Email**

Email responses are returned within 24 hours of receipt.

### **7.5 Flexible Production Capabilities**

Our independent demand production area allows us to provide single, custom controllers, while our lean manufacturing assembly lines give us the capability to process large volume requests.

### **7.6 Testing**

All custom Pump Controllers are tested in-house by a certified test technician before being packed and shipped.

### **7.7 Local Representation**

In the United States, Eaton Cutler-Hammer provides local support through our network of Pump Controller factory trained agents.

### **7.8 Start Up**

Each agent is available for local sales and technical support including on-site start up assistance.

### **7.9 Spare Parts**

All Eaton Cutler-Hammer authorized agents have quick access to spare parts for emergency situations.

### **Note:**

For support in territories where there are no Eaton Cutler-Hammer authorized sales agents, please contact the factory direct.

FIGURE 1: TYPICAL DIMENSION DRAWING

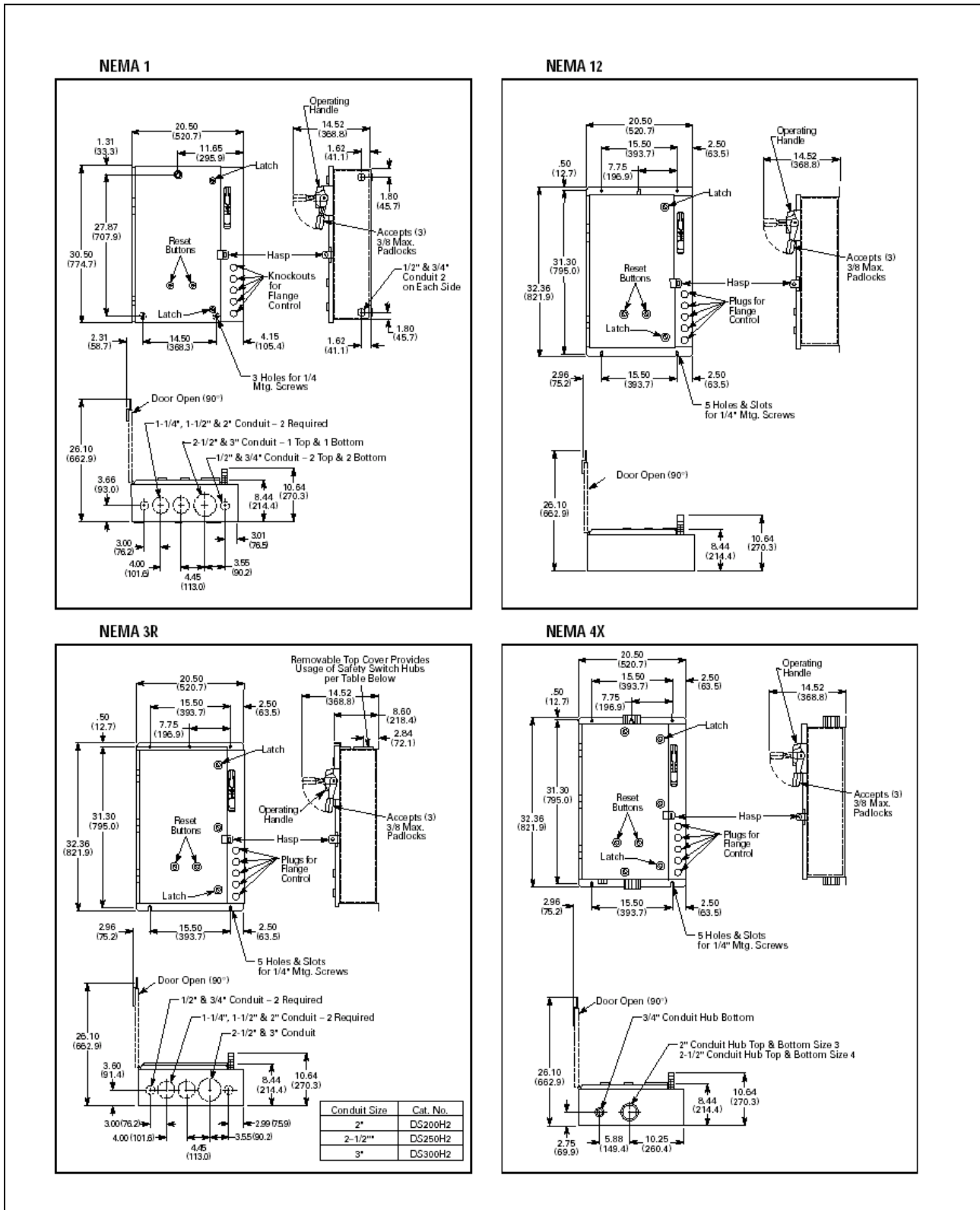
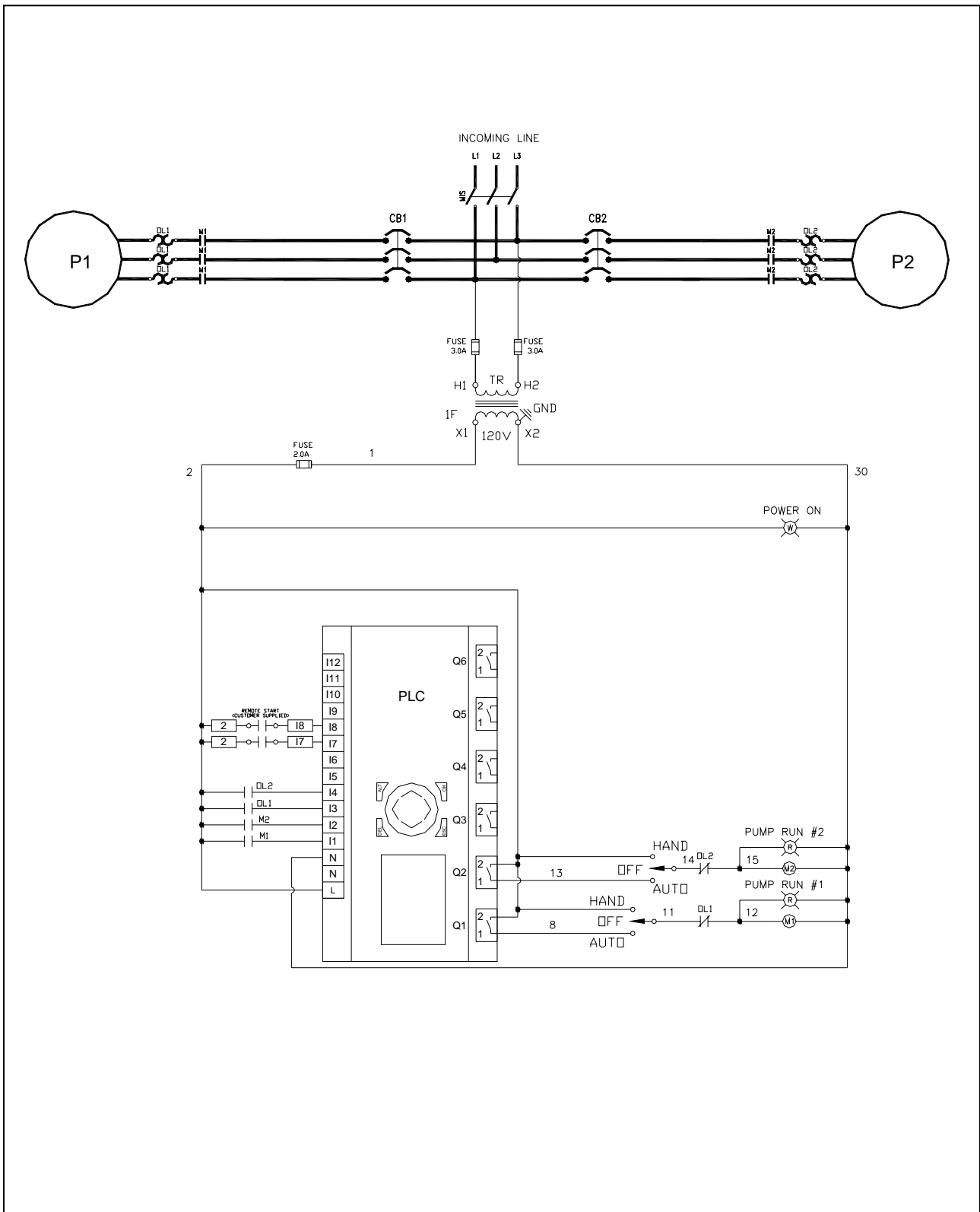

FIGURE 2: TYPICAL WIRING SCHEMATIC – PLC Based Controller





© 2009 Eaton Corporation  
All Rights Reserved  
Printed in Canada  
Publication No.: IM05805007K  
February 2009

Eaton Corporation  
10725 - 25th Street NE Unit 124  
Calgary, Alberta, Canada  
T3N 0A4  
Tel: +1-403-717-2000  
Fax: +1-403-717-0567  
email: [chcfirepump@eaton.com](mailto:chcfirepump@eaton.com)  
[www.chfire.com](http://www.chfire.com)