

- 1 - EPCT TOUCHSCREEN
- 2 - EXTERNAL USB PORT
- 3 - MAIN POWER SWITCH
- 4 - START PUSHBUTTON
- 5 - STOP PUSHBUTTON
- 6 - MSH (EMERGENCY START HANDLE)
- 7 - RECOMMENDED CABLE ACCESS (BOTTOM ONLY)

**NOTES:**  
 1 - DIMENSIONS: in [mm]  
 2 - ALL ENCLOSURES FINISHED IN RED  
 3 - STANDARD ENCLOSURE: TYPE (NEMA) 2

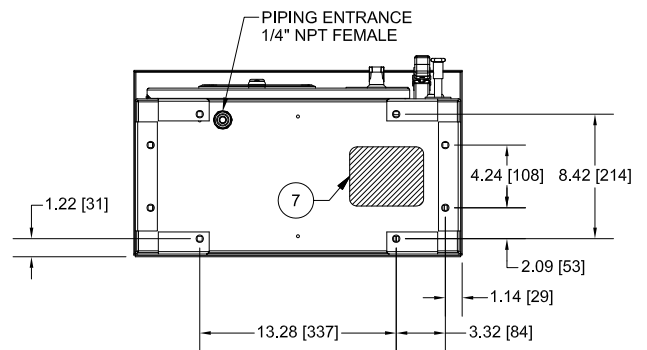

Motor HP	Line voltage	Withstand rating		Approximate weight
		Standard	Intermediate	Lbs. (Kg)
5 - 30	200 - 208V	25,000	65,000	180 (81)
5 - 30	220 - 240V			
5 - 30	380 - 415V *			
5 - 30	440 - 480V			
5 - 30	550 - 600V	18,000	25,000	
5 - 15	240V - S/P	10,000	65,000	