

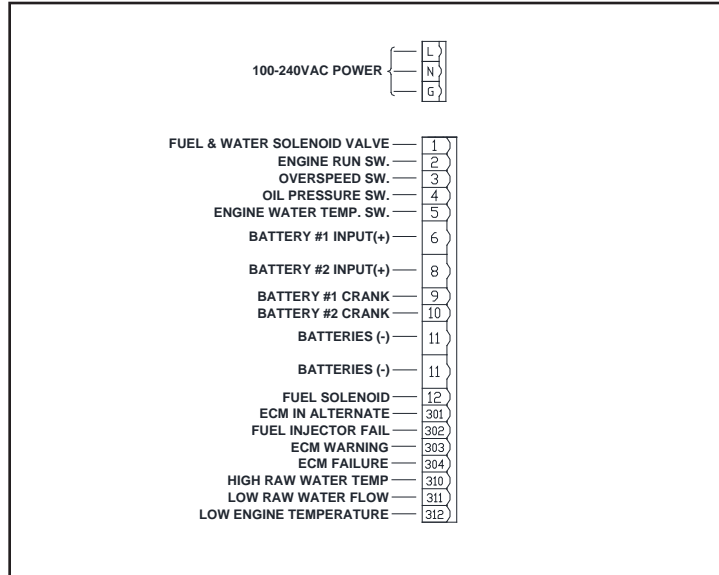

## Field Connections

### Engine Board Terminal Blocks



### Inputs

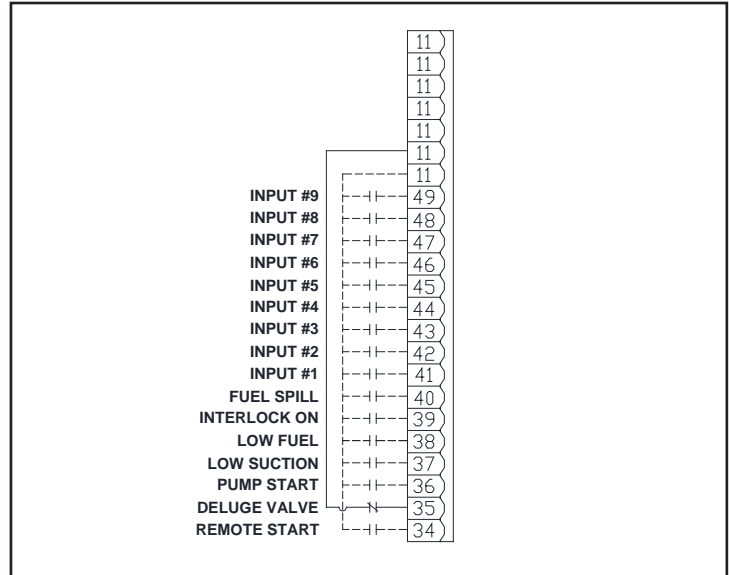

### Outputs

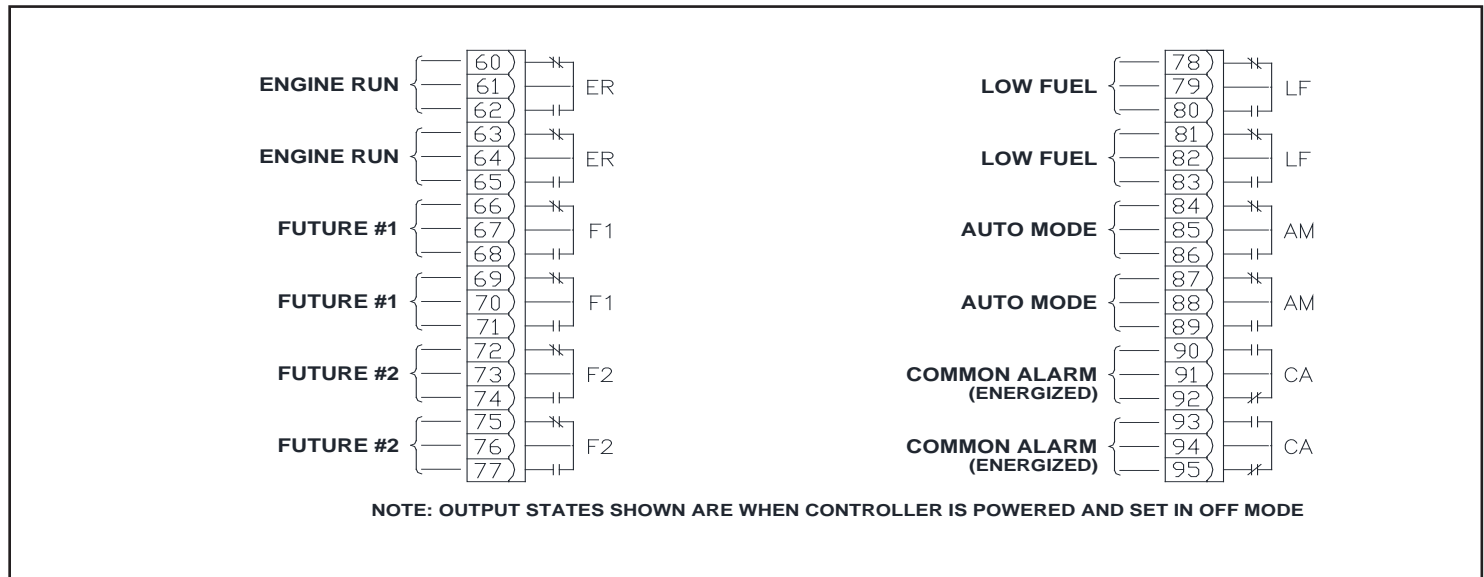

## Technical Data and Specifications

### Line Terminals (Incoming Cables)

Recommended Wire Size	Terminal Number	Distance
I/O Board Stranded # 14 (1.63mm) Stranded # 14 (1.63mm)	11, 34-39, 60-95 Option Board Terminals	N. A. N. A.
Engine Board Stranded # 14 (1.63mm)	1-5, 9, 10, 12, 301, 302, 303, 304, 310, 311, 312 L, N, G	N. A.
Battery Wire Stranded # 10 (2.59mm) Stranded # 8 (3.26mm)	6, 8, 11 6, 8, 11	0 feet to 25 feet (7.62m) 25 feet to 50 feet (7.62-15.24m)