

- 1 - EPCT TOUCHSCREEN
- 2 - EXTERNAL USB PORT
- 3 - MAIN ISOLATING SWITCH POWER SWITCH
- 4 - CIRCUIT BREAKER POWER SWITCH
- 5 - START PUSHBUTTON
- 6 - STOP PUSHBUTTON
- 7 - MSH (EMERGENCY START HANDLE)
- 8 - RECOMMENDED CABLE ACCESS (BOTTOM ONLY)

NOTES:
 1 - DIMENSIONS: in [mm]
 2 - ALL ENCLOSURES FINISHED IN RED
 3 - STANDARD ENCLOSURE: TYPE (NEMA) 2

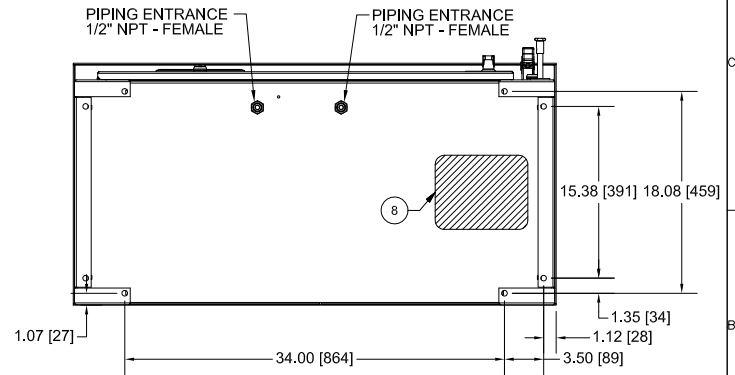

Motor HP	Line voltage	Withstand rating			Approximate weight Lbs. (Kg)
		Standard	Intermediate	High	
200 - 250	200 - 208V	100,000	N/A	N/A	575 (260)
250 - 300	220 - 240V				
350 - 500	380 - 415V				
450 - 600	440 - 480V				
550 - 700	550 - 600V	25,000			