



Product Description

EATON's Automatic Transfer Switches provide automatic transfer of an electrical load to a standby power supply in the event of drop or loss of voltage of any or all phases of the normal power supply.

Upon the restoration of the normal supply, the electrical load is automatically re-transferred to the normal power supply.

Transfer Switch Features

Electrically and Mechanically Interlocked

The FPATS transfer switch operating mechanisms are mechanically interlocked to prevent the normal and alternate source from connecting at the same time. The switch operates upon signals received from the ATC-300 Plus controller.



Engine Test Button

An engine test button is provided on the ATC-300 controller that can be used to test the Source 2 (generator) engine. The operator can select the engine run test time (0-600 minutes). As well, a silence pushbutton is provided which de-energizes the alarm bell.

Automatic Transfer

The FT Series Transfer Switches will perform an automatic transfer from Normal to Alternate source when the Voltage drops to 85% of normal, or there is a loss of any phase and/or Phase Reversal.



Alarm Relay

The alarm relay is de-energized to indicate an absence of an alarm state and energized to indicate the presence of an alarm condition. Alarm conditions include:

- Improper Circuit Breaker Operation
- Motor Operator Failure
- Lockout
- Failsafe Condition
- Aborted Engine Test
- Aborted Plant Exerciser

Product Features

ATC-300 Plus

The panel mounted, multi-function, microprocessor based ATC-300 Plus controller accurately monitors two power sources and provides the necessary intelligence to reliably operate the transfer switch through a series of programmed sensing and timing functions.



Keypad Programming

The ATC-300 Plus controller membrane is equipped with seven keypad input buttons which are used to program the controller as well as set operating parameters.

Voltage and Frequency Sensing

The ATC-300 Plus continuously monitors the normal source for out of range setpoint values. When the source is outside the dropout setpoints, the source will become unavailable. This prompts a transfer to the alternate source. Retransfer occurs when the normal source's frequency and/or voltage return within pickup setpoints.

LED Status Indication

Five LED's indicate the status of the power sources.

Source 1 Available	Source 1 Connected
Source 2 Available	Source 2 Connected
Unit Status	

Source 1 (Normal) Available

The white Source 1 Available LED illuminates when the Source 1 power source is within the setpoint ranges for the nominal voltage and frequency setting.

Source 2 (Normal) Connected

The green Source 1 LED illuminates when the Source 1 switching device and its associated position indicating auxiliary contact are closed.

Source 2 (Emergency) Available

The amber Source 2 Available LED illuminates when the Source 1 power source is within the setpoint ranges for the nominal voltage and frequency setting.

Source 2 (Emergency) Connected

The red Source 2 Connected LED illuminates when the Source 2 switching device and its associated position indicating auxiliary contact are closed.

Input Pushbuttons

Step / Enter

The Step/Enter pushbutton allows the user to scroll through the information and setpoint displays. When the Step/Enter button is pressed, the information on the LCD display advances through the voltage(s), frequency, and status condition of Source 1, then Source 2, then the time and date information, then the history information, then the setpoints - one step at a time.

Increase

The Increase button allows the user to increase the value of the setpoints. When the ATC-300 is in the "Program" Mode, each time the Increase button is pressed, the value of the displayed item will increase by one.

Decrease

The Decrease button allows the user to decrease the value of the setpoints. When the ATC-300 is in the "Program" Mode, each time the Decrease button is pressed, the value of the displayed item will decrease by one.

Alarm Reset Function

Pressing the Increase and Decrease buttons simultaneously will reset the Alarm function. If this is done while viewing any of the historical logged values in the program mode, the value of the current item resets to zero.

Bypass Time Delay Function

(Step/Enter+Help/Lamp Test)
Pressing the Step / Enter and Help / Lamp Test buttons simultaneously, will bypass the TDNE or TDEN functions when they are actively timing.

Help / Lamp Test

If the Help/Lamp Test pushbutton is pressed when a message is present on the LCD Display, a detailed description of the message will appear. It will scroll across the bottom of the display.

If the LCD Display is displaying the Home screen when the Help/Lamp Test key is pressed, all of the LED's will momentarily illuminate, then the following information will scroll across the display:

Serial Number of the ATC-300 Plus controller, Hardware Revision number, Software Versions and Revision number, Feature Code, Firmware Version

Technical Data and Specifications

Line Terminals (Incoming Cables)

	Line Terminals on Main Isolation Switch (Incoming Cables)						
	LINE VOLTAGE					Quantity & Cable Sizes	Service Entrance Ground Lug Quantity & Cable Sizes
	200-208	220-240	380-415	440-480	550-600		
Max HP	25	30	40	60	75	(1)#14-1/0 PER Ø (CU/AL)	(1)#14-2/0 (CU/AL)
	40	50	75	100	100	(1)#4-4/0 PER Ø (CU)	(1)#4-350MCM (CU/AL)
	75	75	150	200	200	(1)#3-350MCM PER Ø (CU/AL)	(1)#4-350MCM (CU/AL)
	100	125	200	250	300	(2)3/0-250MCM PER Ø (CU/AL)	(2)1/0-750MCM (CU/AL)
	150	200	350	400	400	(2)250-350MCM PER Ø (CU/AL)	(2)1/0-750MCM (CU/AL)

Installation Parameters

NFPA 20 - Arrangement II Individually Listed Fire Pump Controllers and Power Transfer Switch

When applying Arrangement II, all installations should comply with NFPA 20 - Section 9.3.2 and Section 10.8.2.2.

NEMA 2 Enclosures

All FPATS transfer switches come standard with NEMA 2 enclosures unless otherwise ordered. Available options include: NEMA 3R, 4, 4X, 12.

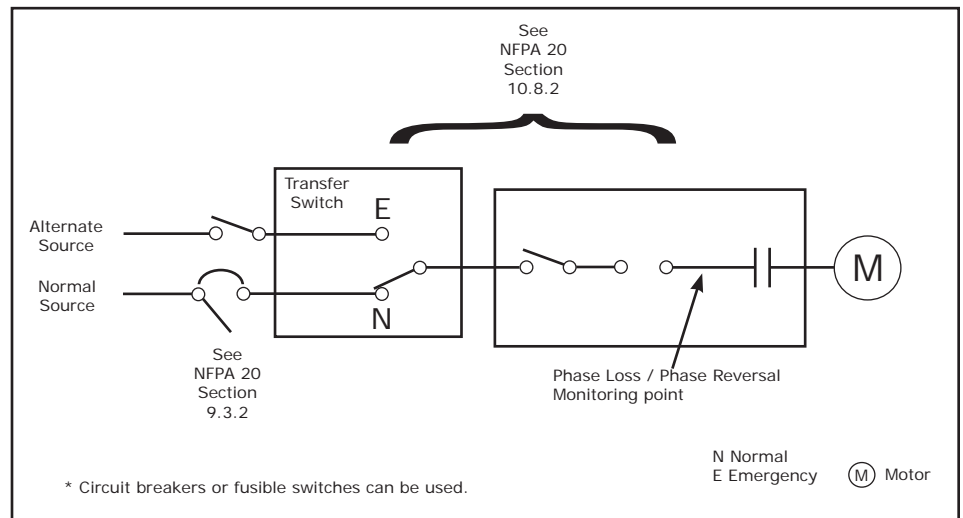

NFPA 20 - Arrangement II

Standards & Certification

The FPATS transfer switches meet or exceed the requirements of Underwriters Laboratories, Underwriters Laboratories Canada, the Canadian Standards Association, New York City building code, U.B.C. / C.B.C. seismic requirements, and are built to NFPA 20 standards.



N. Y. C. APPROVED



Transfer Switch Terminal Block

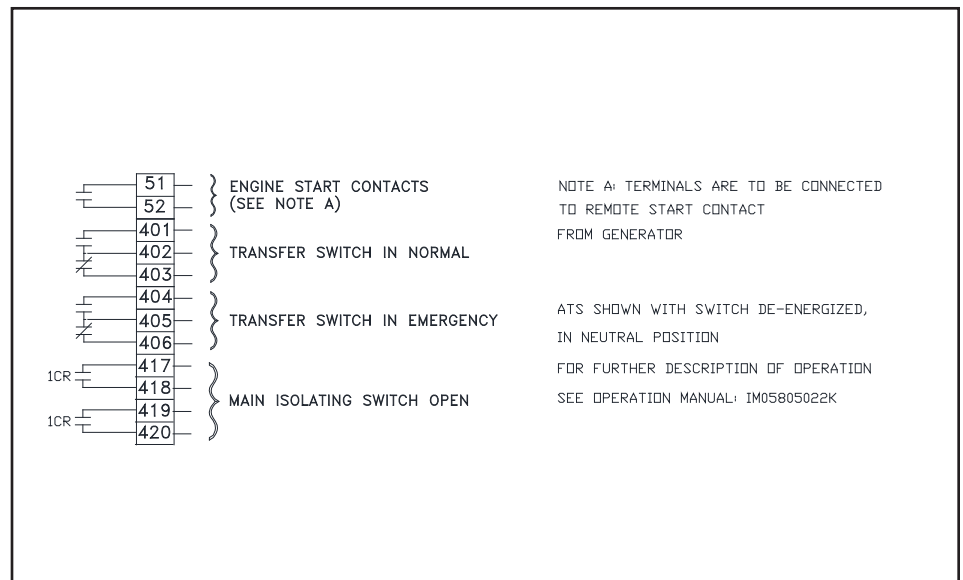

Main Display

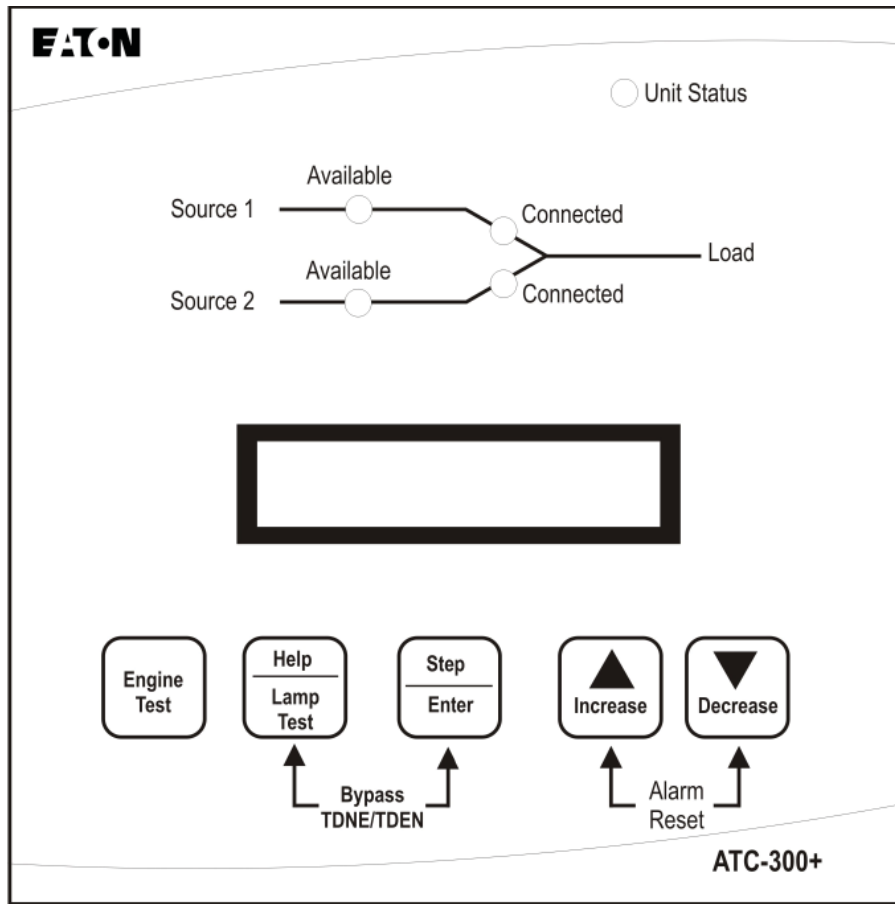

Note: For setup and programming information, refer to the Operation Manual for the EATON ATC-300 Plus Automatic Transfer Switch Controller - IM05805022K

Dimensions

Standard Enclosure - Type NEMA 2, 3R, 12

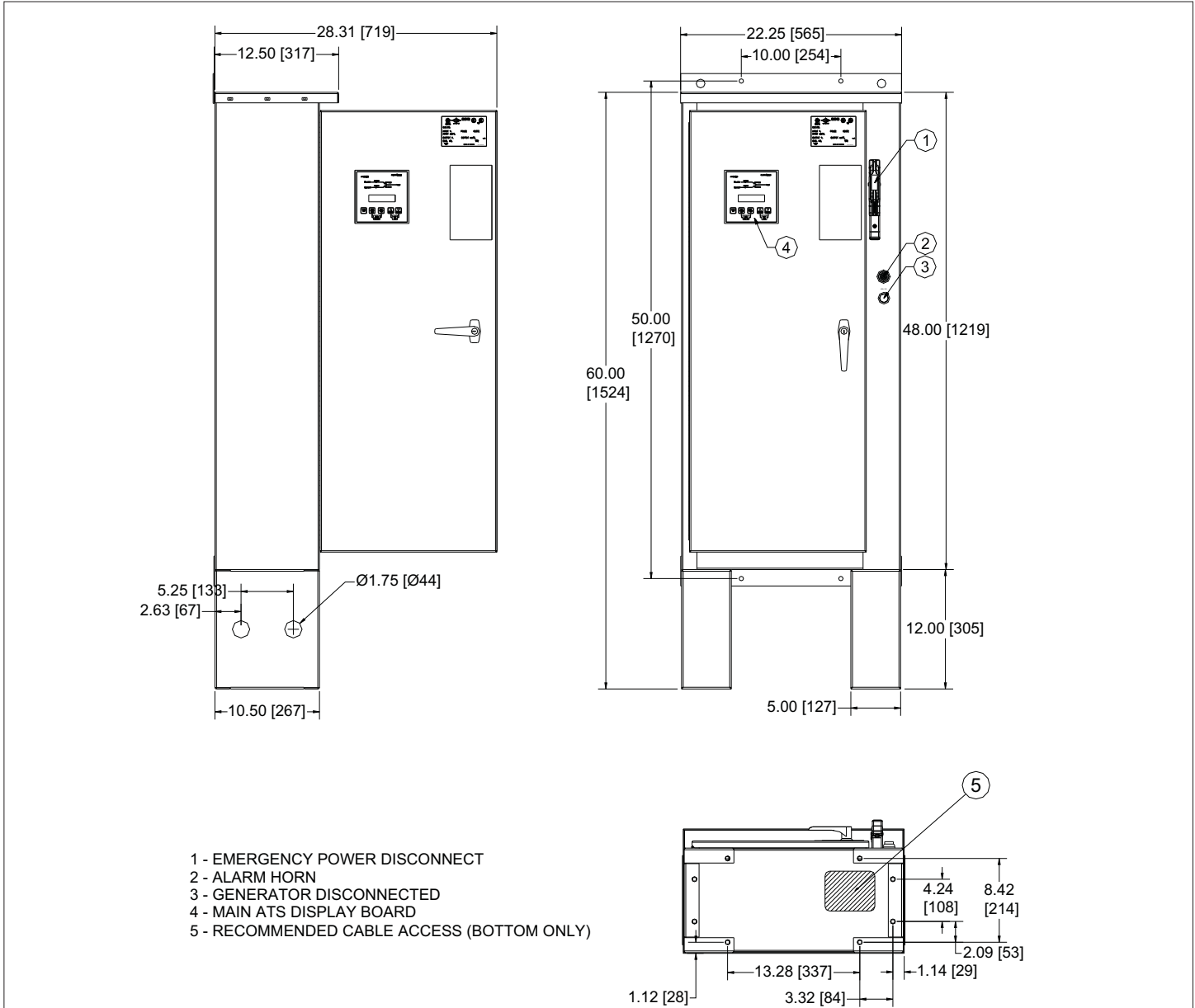

Dimensions in inches and [millimeters].

Motor Hp	Line Voltage	Withstand Rating			Approx. Weight Lbs. (Kg)
		Standard	Intermediate	High	
5 - 40	200 - 208V	100,000	Consult Factory	Consult Factory	180 (81)
5 - 50	220 - 240V				
5 - 75	380 - 415V	65,000			
5 - 100	440 - 480V				
5 - 100	550 - 600V	25,000			



N. Y. C.
APPROVED



NOTES:

1. All enclosures finished in FirePump red.
2. Cable Entrance bottom only.
3. Standard Enclosure type NEMA 2.

Electrical Wiring Schematic

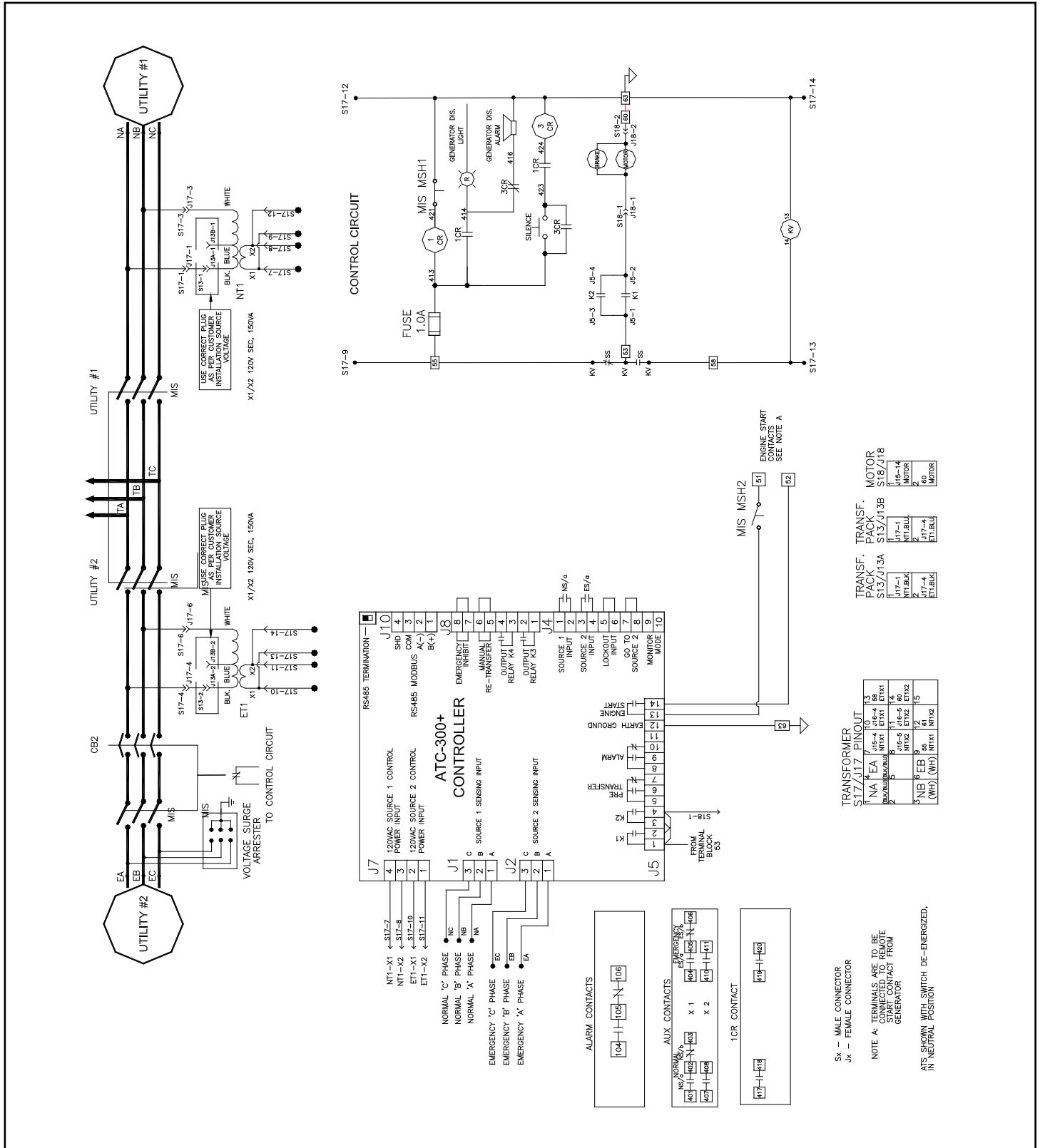

TRANSFORMER S17/J17 PINOUT

1	NA	EA	10	13
2	NB	EB	11	14
3	NC	EC	12	15
4	NT1	NT1 BLK	16	17
5	NT1	NT1 BLU	18	19
6	NT1	NT1 WHT	20	21

TRANSF. PACK S13/J13A

1	1A	1B	1C
2	2A	2B	2C

TRANSF. PACK S18/J18

1	1A	1B	1C
2	2A	2B	2C

Sx - MALE CONNECTOR
Jx - FEMALE CONNECTOR

NOTE A: TERMINALS ARE TO BE CONNECTED TO REMOTE GENERATOR

ATS SHOWN WITH SWITCH DE-ENERGIZED, IN NEUTRAL POSITION

Field Connections

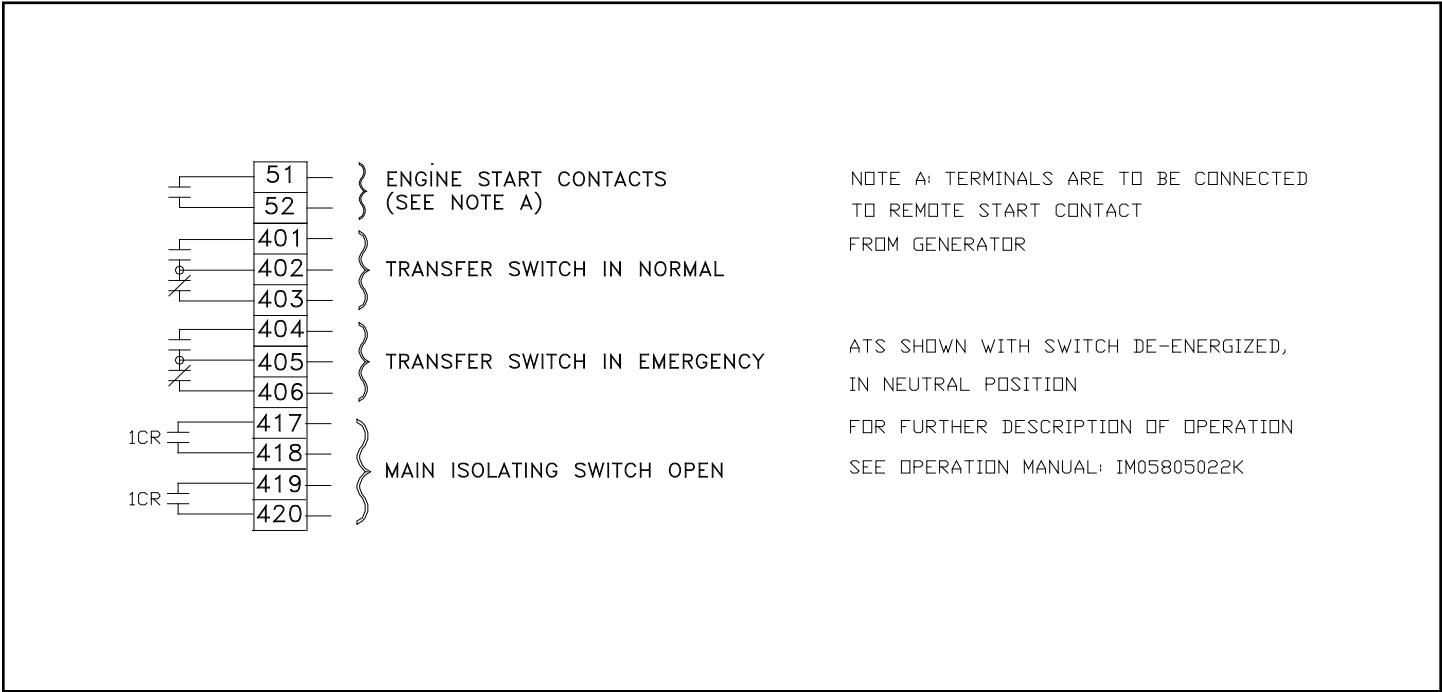

	Line Terminals on Main Isolation Switch (Incoming Cables)						Service Entrance GND. LUG Qty. & Cable Sizes
	LINE VOLTAGE					Qty. & Cable Sizes	
	200 - 208	220 - 240	*380 - 415	440 - 480	550 - 600		
Max HP	25	30	40	60	75	(1)#14-1/0 PER Ø (CU/AL)	(1)#14-2/0 (CU/AL)
	40	50	75	100	100	(1)#4-4/0 PER Ø (CU)	(1)#4-350MCM (CU/AL)
	75	75	150	200	200	(1)#3-350MCM PER Ø (CU/AL)	(1)#4-350MCM (CU/AL)
	100	125	200	250	300	(2)3/0-250MCM PER Ø (CU/AL)	(2)1/0-750MCM (CU/AL)
	150	200	350	400	400	(2)250-350MCM PER Ø (CU/AL)	(2)1/0-750MCM (CU/AL)



N. Y. C. APPROVED



**Part Number / Options Selection Guide
Stand Alone Automatic Transfer Switches**



FPATS

Horsepower				
5	25	75	250	500
7.5	30	100	300	550
10	40	125	350	600
15	50	150	400	650
20	60	200	450	700

Voltage
A = 208V - 60HZ
B = 240V - 60HZ
C = 380V - 50HZ
D = 480V - 60HZ
E = 600V - 60HZ
F = 415V - 50HZ
H = 380V - 60HZ
J = 400V - 50HZ
K = 400V - 60HZ

Options
E1 = NEMA 3R - Raintight Enclosure
E3 = NEMA 12 - Industrial Dust Tight Enclosure

Language
L1 = English
L2 = French
L4 = Italian
L5 = Spanish
L6 = Portuguese
L7 = Chinese
L8 = Polish
L9 = Dutch
L11 = Turkish



N. Y. C.
APPROVED



Typical Specifications

1. Approvals

- A. The Fire Pump Controller and Transfer Switch combination shall meet the requirements of the latest edition of NFPA 20 and shall be listed by [Underwriters Laboratories (UL)] and approved by [Factory Mutual] (FM) **, [Canadian Standards Association (CSA)] and [New York Department of Buildings (NYSB)] for fire pump service.
- B. The transfer switch shall meet UL 1008 and shall be regularly subjected to Endurance, Interrupting Capacity, and Dielectric Voltage-Withstand test as outlined by UL 489 standards.

2. Ratings

- A. The transfer switch shall be suitable for the available short circuit current at the line terminals of the controller.
- B. The transfer switch shall have an ampere rating not less than 115% of the motor full-load current.

3. Construction

- A. The transfer switch shall be installed in a barriered compartment of the fire pump controller. The complete assembly, controller and transfer switch, shall be shipped as a single unit.
- B. A single uni-gear motor shall electrically operate the transfer mechanism. It shall also be capable of being operated manually and shall have suitable provisions for readily disengaging the gear motor when necessary.
- C. The transfer switch shall be mechanically and electrically interlocked so that it shall not be possible for the load circuits to be connected to normal and emergency sources simultaneously, regardless of whether the switch is electrically or mechanically operated. The switch shall have a manual neutral.
- D. The alternate side shall be provided with an isolation switch sized to a minimum of 115% of the motor full-load current and a circuit breaker having a continuous current rating not less than 115% of the motor full load amps. The isolation switch shall have overcurrent sensing elements of the non-thermal type, and instantaneous short-circuit overcurrent protection. (This does not apply to FPATS Stand Alone and FT20 Limited Service Transfer Switch Controllers.)
The isolating switch and circuit breaker shall be mechanically interlocked and operated by a single handle. (This does not apply to FT20 Limited Service Transfer Switch Controllers.)
The isolating switch shall be supervised to indicate when it is opened by audible and visual alarms.
- E. An auxiliary contact shall be provided to prevent sending of the signal for starting of the alternate source generator when the transfer switch commands it, if the isolation switch on the alternate source side of the transfer switch is open.
- F. The transfer switch shall be provided with locked rotor overcurrent protection. The locked rotor protector shall be calibrated and set to a minimum of 300% of the motor full-load current and have a tripping time between 8 and 20 seconds. (This does not apply to FT20 Limited Service Transfer Switch controllers.)

4. Enclosure

- A. The controller shall be housed in a NEMA Type 2 (IEC IP11) drip-proof, powder baked finish, freestanding enclosure.

5. Microprocessor Control

- A. A solid state sensing and control logic panel shall be separately mounted from the power-switching portion of the transfer switch. The two sections shall be connected together by control cables and plug-in connectors. The control section shall be capable of being isolated from the power section for maintenance.
- B. The normal power source shall be set to pickup at 95% and drop out at 85% of nominal supply. The voltage sensing on the alternate supply shall be set to pickup at 95% of nominal voltage.
- C. All voltage sensing, frequency sensing, and timer set points shall be field adjustable.
- D. The transfer switch shall automatically transfer its load circuit to an emergency or alternate power supply upon failure of the normal or original supply. In order to override momentary fluctuations in the system, a time delay transfer from normal to alternate power supply shall be adjustable up to 1800 seconds. Upon restoration of the normal supply, the transfer switch shall automatically retransfer its load circuits to the normal supply. Mechanically held transfer mechanisms shall be energized only momentarily during transfer or retransfer.
- E. If the emergency / standby power should fail while carrying the load, transfer to the normal supply shall be made instantaneously upon restoration of the normal source to satisfactory conditions.
- F. The transfer switch shall come complete with five LED's to provide visual indication of the unit status, source 1 available, source 1 connected, source 2 available, and source 2 connected.
- G. An engine test button shall be provided that will initiate an engine test.
- H. A silence alarm button shall be provided that will silence the alarm buzzer.

6. Alarm Relays

- A. 1 Form-C contact shall be provided for remote indication for source 1 connected or source 2 connected.
- B. 2 Form-C contacts shall be provided for remote indication for the alternate source-isolating switch open.

7. Manufacturer

- A. The manufacturer of the assembly shall be the manufacturer of major components and control modules installed within the assembly.
- B. The Transfer Switch Fire Pump Controller shall be of the LMR Plus type as manufactured by Eaton Industries (Canada) Company.
- C. Models:
 - FT20 Limited Service
 - FT30 Across the Line
 - FT40 Part Winding
 - FT50 Primary Resistor
 - FT60 Autotransformer
 - FT70 Wye-Delta (Star Delta) Open Transition
 - FT80 Wye-Delta (Star Delta) Closed Transition
 - FT90 Soft Start
 - FPATS Stand Alone Transfer Switch

** NOTE: FPATS Stand Alone and FT20 Limited Service Transfer Switch controllers, do not carry FM Approval.