

FlexiTech SL lens optic 400lm CG-S



Target group: Skilled electricians
Zielgruppe : Elektrofachkraft



Intended application: Emergency lighting, not suitable for private use.
Verwendungszweck: Notbeleuchtung, nicht für privaten Gebrauch.

IP43 White flexible material
Weißes flexibles Material

IP65 Black flexible material
Schwarzes flexibles Material

2,5 mm

PZ0

x 2
Ø 5 mm



For working on the installation, please ensure first the emergency lighting system is blocked, the battery operation is interrupted, and the mains is OFF.

Stellen Sie bei Arbeiten an der Installation sicher, dass zuerst das Notbeleuchtungssystem blockiert, der Batteriebetrieb unterbrochen und das Stromnetz ausgeschaltet ist.

1

a

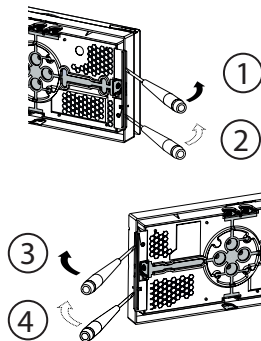

b

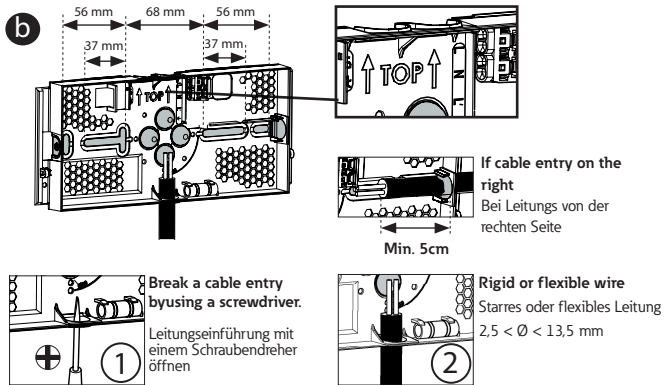

c

Drill in the honeycomb zones (IP43) or in the 4 flexible material parts (IP65).
Bohren Sie in den Wabenzonen (IP43) oder im flexiblen Material (IP65).



Drilling zones to avoid
Zu vermeidende Bohrzonen

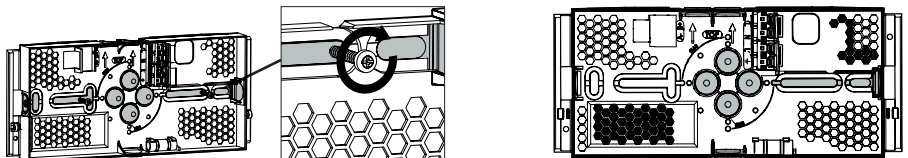

Powering Business Worldwide



$S < 1,5 \text{ mm}^2$

Use screwdriver to place and remove wire
 Stecken und Entfernen der Leitungen mittels Schraubendreher

$1,5 < S < 2,5 \text{ mm}^2$

No screwdriver required for connection
 Stecken der Leitung ohne Schraubendreher möglich

min. 8 mm



Check the packaging for the whole cabling details.
 Überprüfen Sie die Verpackung auf die gesamten Verkabelungsdetails

220-240V AC - 50/60 Hz
 176-275V DC

L —
N —

Max. 6A

Addressing/Adressierung

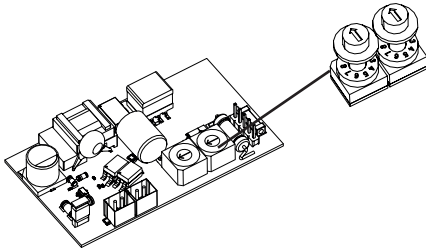

	0 + 0 =	No address (without CG-S monitoring)/ Keine Adresse (ohne CG-S Überwachung)
	0 + 1 = 1	
	0 + 9 = 9	
	1 + 0 = 10	
	1 + 1 = 11	
	2 + 0 = 20	

Max. 20

Optional

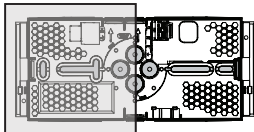
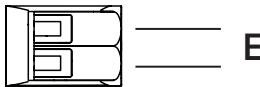

$0,5 < S < 2,5 \text{ mm}^2$

3

a

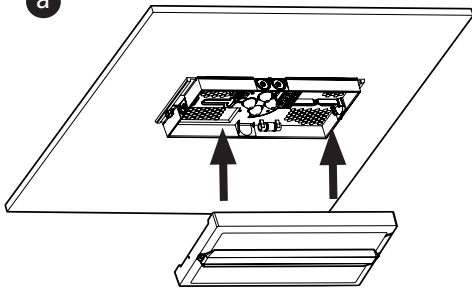

b

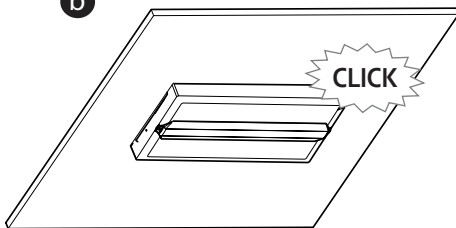

CBS

Power consumption mains operation
(apparent/effective power)
Anschlussleistung Netzbetrieb
(Scheinleistung / Wirkleistung)



EN

FT2SE400CGS	9.1VA / 5.4W	20M	IP43 / IK07	36 x LED 3V 600mA	400 lm	EN60598.1 EN 60598.2.22
FT2SE400CGSIP	9.1VA / 5.4W		IP65 / IK07	36 x LED 3V 600mA	400 lm	



Not replaceable
Nicht austauschbar

When the life time of light source is over, replace the luminaire.
Wenn das Lebensdauerende der Lichtquelle erreicht wurde, ersetzen Sie die Leuchte.



Eaton
Cooper Sécurité SAS
PEE II - Rue Beethoven - BP10184
63204 RIOM CEDEX FRANCE
Tél. +33 (0)825 826 212 (0,15 € TTC/min)
www.cooperfrance.com
www.eaton.com

Eaton
EMEA Headquarters
Route de la Longeraie 7
1110 Morges, Switzerland
Eaton.eu

© 2021 Eaton
All Rights Reserved



ZNO2058600 A- 04/2021

WEEE: Contact your local dealer

Eaton is a registered trademark.

Eaton.com/recycling

All trademarks are property
of their respective owners.



EATON

Powering Business Worldwide