

276-310

DO NOT SCALE

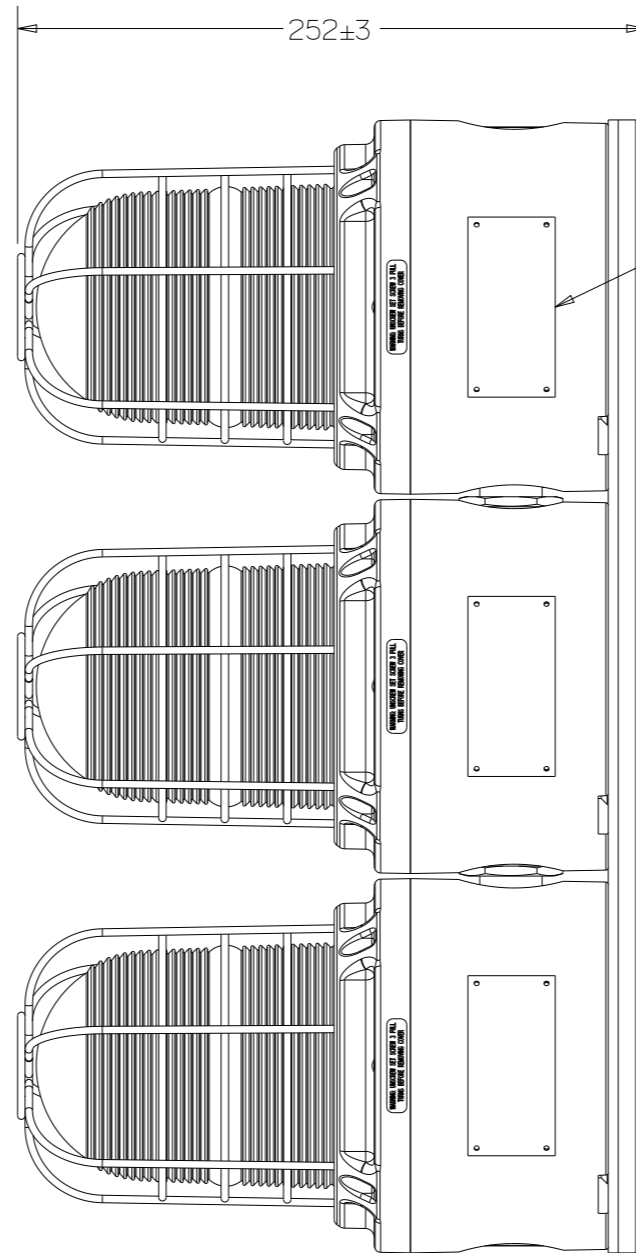
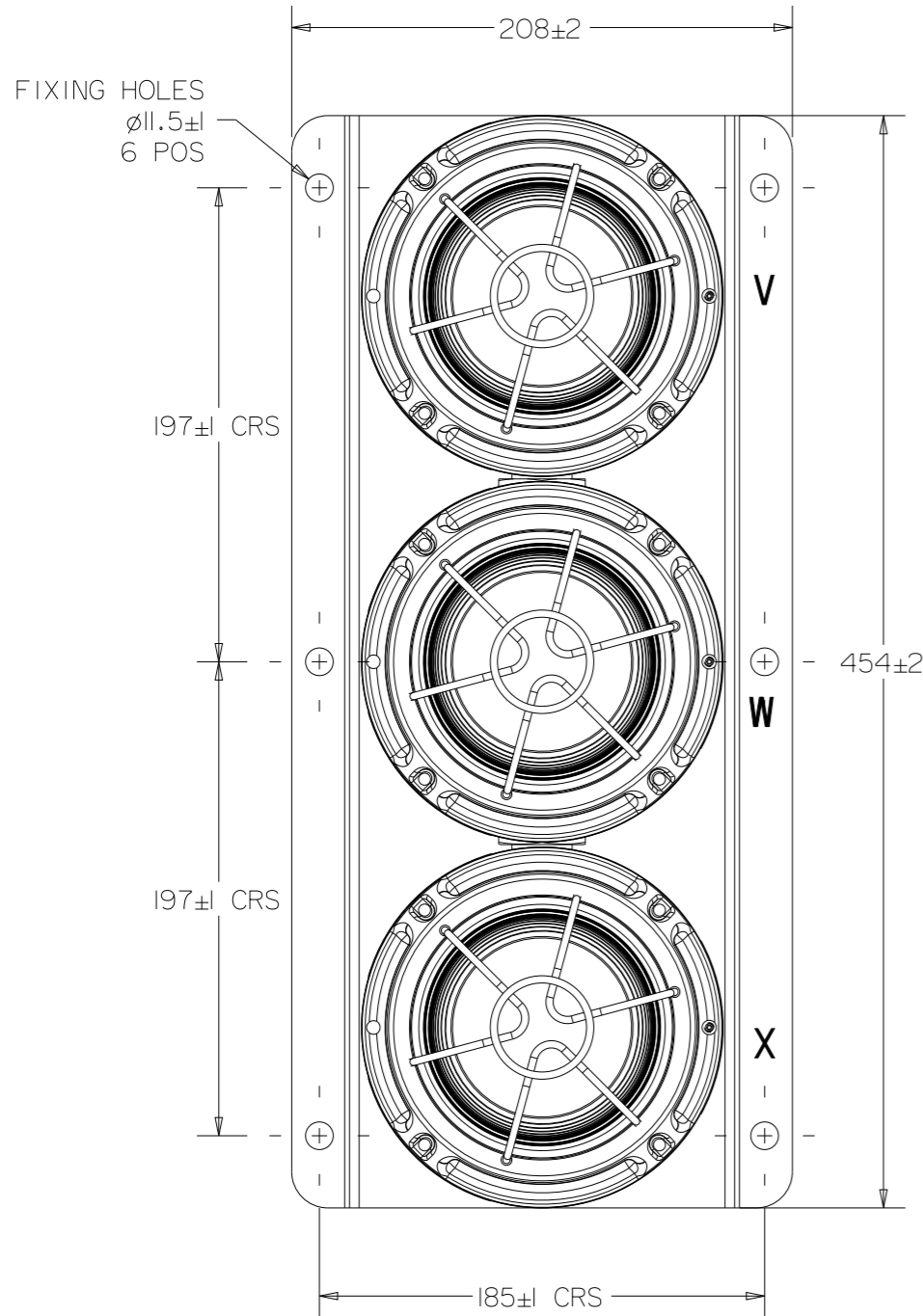
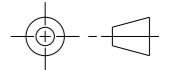

CERTIFICATION LABEL

NOTES:

1. TYPE SLI5 3-WAY
2. CERTIFICATION:  
ATEX: CERTIFICATION No. BASO4ATEX0009X  
II 2 GD Ex db IIC Gb  
Ex tb IIIC Db  
IECEX: CERTIFICATION No. IECEX BAS 05.0048X  
Ex db IIC Gb  
Ex tb IIIC Db
3. TEMPERATURE RANGE AND T-RATINGS:  
(-55°C to +70°C)  
XENON: T4/T5/T6  
FILAMENT: T3/T4  
LED: T5/T6
4. WEIGHT:- 11.8Kg MAX. (CONFIGURATION DEPENDENT)  
(INDIVIDUAL LDI5 UNITS ARE TYPICALLY 0.5Kg HEAVIER THAN XBI5 AND FBI5 UNITS)
5. MATERIAL:- ENCLOSURE AND COVER: GLASS REINFORCED POLYESTER  
BASE PLATE: STAINLESS STEEL GRADE 316
6. OPTIONAL TAG/DUTY LABEL, LETTER SIZE 5mm MAX.
7. TERMIALS ARE SUITABLE FOR UP TO 2.5mm<sup>2</sup> CABLE
8. ENTRIES:- UP TO 2xM25 ENTRIES IN UNITS V & X
9. POSITIONS V, W & X: ANY COMBINATION OF LDI5/FBI5/XBI5 UNITS
10. BACKPLATE THICKNESS: 2.0 ±0.5mm

**MEDC** Cooper MEDC Ltd, Unit B, Sutton Parkway, Oddicroft Lane, Sutton-in-Ashfield, Nottinghamshire, NG17 5FB, U.K.  
Tel: +44 (0) 1623 444400 web: www.coopermedc.com

DESIGNERS & MANUFACTURERS OF ELECTRICAL & ELECTRONIC EQUIPMENT & SYSTEMS FOR HAZARDOUS AREAS

ISSUES	B. 22-07-13 PF	ALL DIMENSIONS ARE IN MILLIMETRES UNLESS OTHERWISE STATED	THIS DRAWING IS CONFIDENTIAL AND IS THE PROPERTY OF MEDC AND MUST NOT BE REPRODUCED EITHER WHOLLY OR PARTLY. ALL RIGHTS IN RESPECT OF PATENTS, DESIGNS AND COPYRIGHT ARE RESERVED.
	C. 17-12-15 PF		

REMOVE ALL BURRS AND SHARP CORNERS	MACHINE SYMBOLS THUS

DRAWN BY: P.FISHWICK	DATE: 19-02-08	TITLE SLI5 3-WAY CUSTOMER GA ATEX/IECEX VERSION	SHT 1 OF 1
CHECKED BY: M.SLACK	DATE: 26-02-08		
APPROVED BY: P.FISHWICK	DATE: 26-02-08		
SCALE:	SIZE: A3	DRG No. 276-310	ISSUE C