

## YHWS-12 Series

### Explosion-proof wash spray system



### Overview

This YHWS-12 wash spray system has been designed as the peripheral of Yuhua PTZ camera stations specifically for use of washing the camera window within harsh & demanding environmental conditions. With the water pressure, the water tank can be placed 25~30 meters lower than the camera station.

The system is suitable for use across a wide range of applications with the option of 304 Stainless Steel (polished or painted) or 316L stainless steel.

### Features

- IP65
- 12L water tank made by stainless steel materials
- Multiple ex options available of solenoid valve
- For both indoor and outdoor environment use



### Specifications

Ex certificate:	CNEx09.0752X, in case of ex-proof requirement
Ex mark:	Exmb I / Exmb IIT4
Material:	304 or 316L Stainless Steel.
Operating Temp:	-40°C to +80°C
Atmospheric pressure:	80~110KPa
Humidity:	≤95%RH (+25°C)
Ingress Protection:	IP65
Weight:	3.5Kg, empty
Ship Weight:	7Kg
Water tank volumn:	12L
Water tank size	250(L) x 600(H) x 210(W) mm
Water tank pressure:	<90Kpa
Water tube size:	Inner diameter in 4mm
Voltage:	220Vac (±10%), 50/60Hz
Cable Connection:	2 cores for the power to solenoid valve

### YHWS-12L protective box for the wash tank

Material:	304 or 316L Stainless Steel
Dimension:	347(L) x 249(W) x 105(H) mm
Weight:	4.4Kg
Ship weight:	7.4Kg

### Mounting dimensions (all dimensions in mm)

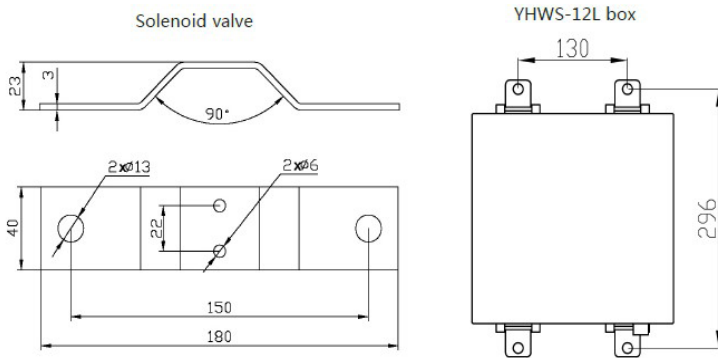

### YHWS-12L box drawing (all dimensions in mm)

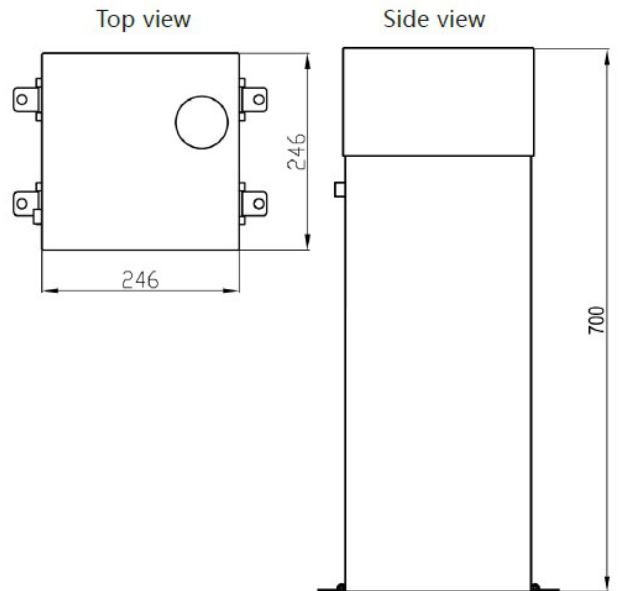

### System arrangement diagram

