

YHW126B HD IP Series

PTZ camera station for both
Ex and safe areas



Overview

Made from 304L or 316L stainless steel and designed specifically for use in hazardous area and or harsh environmental conditions, this hard wearing and corrosion resistant Pan, Tilt, Zoom camera station is suitable for a variety of applications both onshore and offshore in Oil & Gas, Marine, Wind, Chemical and many other industries where quality and durability are a pre-requisite.

The continuous 360° pan rotation and tilt from -90° to +90° gives an unrestricted view of the surrounding area.

With ONVIF protocol as standard, a variety of mounting brackets, wiper/washer tank, fiber optic transmission options, the YHW126B has the operational capability for most demanding CCTV applications.

Features

- CNEx certified.
- IP66 and IP68.
- 1080p HD IP camera.
- -40°C to +65°C.
- 304L or 316L Stainless Steel.
- 360° continuous pan rotation.
- +90° to -90° tilt rotation.
- Multiple scanning mode.
- Automatic Heater.
- Optional fiber optic transmission
- Wiper.

Certifications

ATEX certificate:	CNEx20.1844X
EX mark:	Ex d IIC T6 Gb/Ex tD A21 IP68 T80°C
Vibration and shock test	IEC60068-2-6, IEC60068-2-27 Class B

Specifications

Material:	304L or 316L Stainless Steel
Finish:	Polished
Operating Temp:	-40°C to +65°C
Atmospheric pressure:	80~110KPa
Humidity:	≤95%RH (+25°C)
Automatic heater:	Activates at -10°C
Ingress protection:	IP66 and IP68(1.2m / 45min)
Weight:	33Kg
Ship weight:	51Kg.
Wall bracket load:	100Kg
Voltage:	110VAC to 240VAC (±10%) / 24VAC (±10%) , 50/60Hz
Current:	0.5~1.2A / ≤5A
Power:	≤120W.
Pan:	360° continuous
Pan Speed:	0.1°/S to 45°/S
Tilt:	+90° to -90°
Tilt Speed:	0.1°/S to 40°/S
Presets:	128
Preset accuracy:	≤0.1°
Cable entries:	2 x M25x1.5 with blind plugs
Audio & Alarm connection:	1 for audio input / output and 1 for alarm input / output
Transmission:	Standard Ethernet IP / Fiber optic transmission / IP over Coax transmission
VMS compliance:	ONVIF 2.4 Profile S, T & G
Applicable wash system:	Applicable wash terminals for connection to external wash system driven by solenoid valve or pump. The power voltage input of solenoid valve or pump shall be consistent with voltage input of camera station.

Fiber Optic

Data Interface:	Ethernet 1310/1550nm
Data Rate:	10/100 Mbps IEEE 802.3 Compliant, Full or Half Duplex Electrical Port / Full Duplex Optical Port
Connector:	SC(ST/FC)
Fiber:	Single mode / Multimode
Optical Power Budget:	10 dB
Maximum Distance:	3 km (2 miles)

Ethernet over Coax

Data Interface:	10/100BaseT(X) Ethernet
Data Rate:	DIP switch selection of 10/100 Mbps Full data rate / full duplex up to the maximum rated distance
RFC:	2544 TCP/IP Packet Transmission
Standards:	IEEE 802.3af PoE (CLRFE1EO(C,U)P/M), RFC: 768 UDP, 2068 HTTP, 793 TCP 791 IP, 1783 TFTP, 894 IP over Ethernet
Transmission Distances:	10M (5,000 ft 1,524 m) 100M (2,000 ft 610 m)

Camera options

22x zoom 3MP HD IP camera

Image sensor	Progressive scan CMOS 1/2.8"
Resolution	2304 x 1296 @ 30fps
Lens	22x optical zoom 5.2~114.4mm F1.5~F3.8, horizontal angle of view 53.74° - 2.96°
Min. illumination	Colour : 0.002Lux (F1.5, AGC ON), B/W 0.001Lux (F1.5, AGC ON)
Streaming	Triple streams in H.264, H.265
Features	AGC, AE,AWB,TDN,DNR,BLC,EIS,WDR,Defog,OSD,Day & Night Auto Colour/BW (IR-cut with auto switch)
Standards protocols	L2TP, IPv4, IGMP, ICMP, ARP, TCP, UDP, DHCP, PPPoE, RTP, RTSP, DNS, DDNS, NTP, FTP, UPnP, HTTP, SNMP, SIP.

33x zoom 3MP HD IP camera

Image Sensor	Progressive scan CMOS 1/2.8"
Resolution	2304 x 1296 @ 60fps
Lens	33x optical zoom 4.5~148.5mm F1.5~F4.0, horizontal angle of view 62.93° - 3.67°
Min. Illumination	Colour : 0.001Lux (F1.5, AGC ON), B/W 0.0005Lux (F1.5, AGC ON)
Streaming	Five streams in H.264, H.265
Features	AGC, AE,AWB,TDN,DNR,BLC,EIS,WDR,Defog,OSD,Day & Night Auto Colour/BW (IR-cut with auto switch)
Standards Protocols	L2TP, IPv4, IGMP, ICMP, ARP, TCP, UDP, DHCP, PPPoE, RTP, RTSP, DNS, DDNS, NTP, FTP, UPnP, HTTP, SNMP, SIP.

22x zoom 5MP HD IP camera

Image Sensor	Progressive scan CMOS 1/2.7"
Resolution	2880 x 1620 @ 30fps
Lens	22x optical zoom 5.2~114.4mm F1.5~F3.8, horizontal angle of view 55.46° - 3.09°
Min. Illumination	Colour : 0.003Lux (F1.5, AGC ON), B/W 0.001Lux (F1.5, AGC ON)
Streaming	Triple streams in H.264, H.265
Features	AGC, AE,AWB,TDN,DNR,BLC,EIS,WDR,Defog,OSD,Day & Night Auto Colour/BW (IR-cut with auto switch)
Standards Protocols	L2TP, IPv4, IGMP, ICMP, ARP, TCP, UDP, DHCP, PPPoE, RTP, RTSP, DNS, DDNS, NTP, FTP, UPnP, HTTP, SNMP, SIP.

General arrangement drawing (all dimensions in mm)

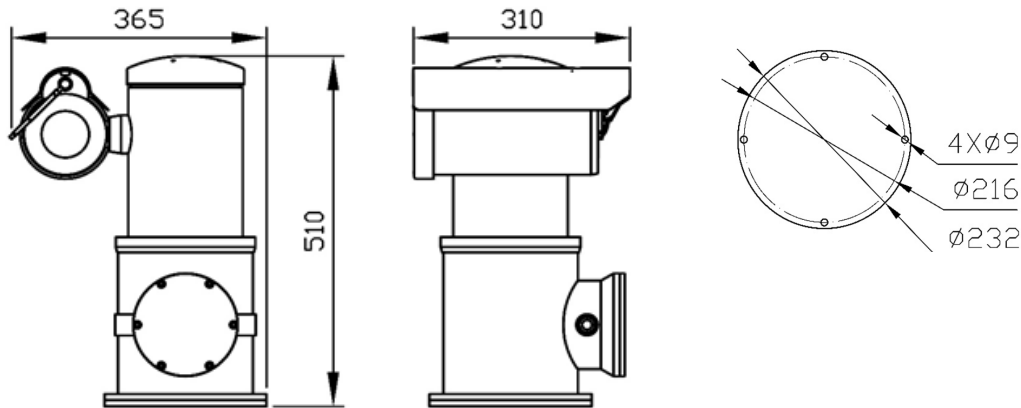

Ordering requirements

The following code is designed to help in selection of the correct unit. Build up the reference number by the code for each selection. Any special requirement please consult Eaton technical sales department.

