

XF60 thermal image analogue series

Explosion proof, fixed camera station



Overview

The Oxalis XF60 is an explosion protected fixed camera housing for use in hazardous areas in onshore, offshore, marine and heavy industrial environments.

The camera housings are designed for longevity in harsh environments with minimal maintenance.

The large format housing allows the installation of custom specified camera, lens and transmission equipment subject to conformity to certification, physical fit and acceptance.

This datasheet covers the thermal imaging configurations.

Features

- ATEX, IECEx, Class 1 Division 1 and Zone 1 certified
 - Electro-polished 316L stainless steel on all welded assemblies
 - Pole or wall mounting options (see separate datasheets)
 - Supply voltage options (24 VAC, 110 or 230 VAC, 50/60Hz)
 - Operating temperature from -60°C to +70°C*
 - IP66/67 (IP68)
- *Model dependent



Certifications

ATEX	II 2 G Ex db (op pr) IICT T4 Gb -60°C to +70°C II 2 D Ex tb (op pr) IIIC T140°C Db IP6x On Request: T5 -60°C to +65°C, T6 -60°C to +40°C On request: T135 -60°C to +65°C Certificate: ITS16ATEX101021X	cLC CSA	Ex d IICT4 (T5 On Request) LC1311396 -60°C ≤Ta ≤ +60°C. CAN CSA-C22.2 No.60079-0:2011 & 60079-1-2012 Certificate: 11396-1S-CSA
IECEX	Ex db (op pr) IICT T4 Gb -60°C to +70°C Ex tb (op pr) IIIC T140°C Db IP6x On Request: T5 -60°C to +65°C, T6 -60°C to +40°C On request: T135 -60°C to +65°C Certificate: IECEX ITS 15.0068X	TR CU, EAC	1 Ex db (op pr) IICT T4 Gb -60°C to +70°C Ex tb (op pr) IIIC T140°C Db IP6x On Request: T5 -60°C to +65°C, T6 -60°C to +40°C On request: T135 -60°C to +65°C Certificate: TCRUCGB.IT504.B00587
INMETRO	Ex db (op pr) IICT T4 Gb -60°C to +70°C Ex tb (op pr) IIIC T140°C Db IP6x On Request: T5 -60°C to +65°C, T6 -60°C to +40°C On request: T135 -60°C to +65°C Certificate: ULBR 17.0063X	CCOE	Ex db (op pr) IICT T4 Gb -60°C to +70°C Ex tb (op pr) IIIC T140°C Db IP6x On Request: T5 -60°C to +65°C, T6 -60°C to +40°C On request: T135 -60°C to +65°C Certificate: P400546/1
LCus CI/ZI	Class 1 Zone 1 A Ex d IICT T4 (T5 On Request) LC13A11396 Gb -60°C ≤Ta ≤ +60°C. UL 60079-0:2009 & 60079-1:2010 Certificate: 11396-1S-UL	CNEX	Ex db (op pr) IICT T4 Gb -60°C to +70°C Ex tb (op pr) IIIC T140°C Db IP6x On Request: T5 -60°C to +65°C, T6 -60°C to +40°C On request: T135 -60°C to +65°C Certificate: 17.1235X
cLCus CI/DI	Class I, Division 1, Groups B, C, D, -60°C ≤Ta ≤ 60°C T4 Class II, Division 1, Groups E, F, G IP67 CSA-C22.2 No:30-M1986 No:25-1966(R2009) CSA-C22.2 No:60065-03(R2012) & UL1203,UL60065(ED.7) Certificate: 11671-1S (Gas) / 11677-1S (Dust)	CERTEX	Ex db (op pr) IICT T4 Gb -60°C to +70°C Ex tb (op pr) IIIC T140°C Db IP6x On Request: T5 -60°C to +65°C, T6 -60°C to +40°C On request: T135 -60°C to +65°C Certificate: S-XLP/170244X

General arrangement drawing (all dimensions in mm)

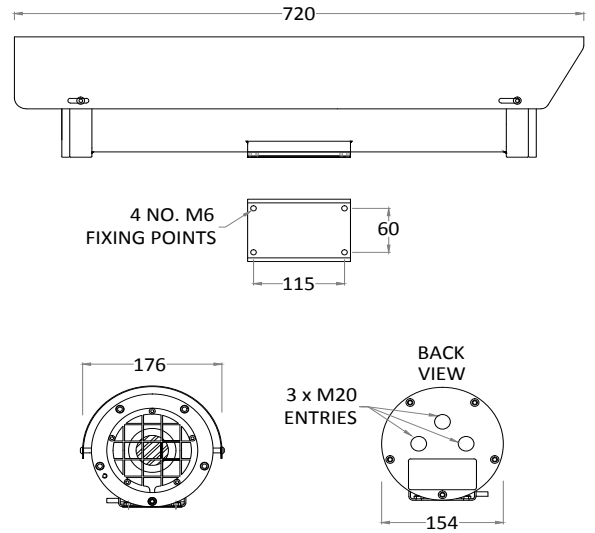

Specifications

Certification part number Housing options 2410-TI, 2410-TI-50

Features	
Sun shield	Standard stainless steel 316L mirror finish
Integral demister	Standard
Telemetry receiver	Integral - Pelco D, P standard protocols (others to specification)
Analogue direct fibre out	Optional singlemode 9/125µm or multimode 50/125µm video and data fibre optic transmission, mounted inside the camera station
Ingress protection rating	IP66/67, IP68 (1.5m for 24 hours)
Type approval	DNVGL-CG-0339, 2016 (copper transmission only)
Electrical	
Supply voltage options	24 VAC, 110 or 230 VAC, 50/60Hz
Power consumption	37W maximum (65W with low temperature operation)
Electrical connections	Terminal block for power, data and video specific to camera configuration
Cable entry	Three M20 entries located in housing rear flange
Mechanical	
Body material	Electro-polished 316L stainless steel on all welded assemblies
Fixings material	A4 stainless steel
Camera station window	Internal AR and external carbon coated germanium (50 or 102mm Ø) with protective grill
Mounting options	Pole or wall (see separate datasheets)
Operating temperature	From -60°C to +70°C (model dependent)
Weight (Kg)	Up to 18 Kg depending on configuration
Thermal core module options	
T336 7.5-8.3Hz	Uncooled VOx microbolometer thermal imaging camera, including TCI Interface PCB for functionality over standard RS485 protocol Commands 336 x 256 resolution, 17µ pixel size, 7.5Hz NTSC/8.3Hz PAL exportable frame rate, digital detail enhancement
T640 7.5-8.3Hz	Uncooled VOx microbolometer thermal imaging camera, including TCI Interface PCB for functionality over standard RS485 protocol Commands 640 x 512 resolution (PAL), 17µ pixel size, 7.5Hz NTSC/8.3Hz PAL exportable frame rate, digital detail enhancement
T336 25-30Hz	Uncooled VOx microbolometer thermal imaging camera, including TCI Interface PCB for functionality over standard RS485 protocol Commands 336 x 256 resolution, 17µ pixel size, 30Hz NTSC/25Hz PAL frame rate, digital detail enhancement. Subject to export restrictions and licensing
T640 25-30Hz	Uncooled VOx microbolometer thermal imaging camera, including TCI Interface PCB for functionality over standard RS485 protocol Commands 640 x 512 resolution (PAL), 17µ pixel size, 30Hz NTSC/25Hz PAL frame rate, digital detail enhancement. Subject to export restrictions and licensing
Thermal core lens options	
19mm lens	FoV 17° x 13° (336 x 256) / FoV 32° x 26° (640 x 512) Detection of object 4m x 1.5m: Typical 1550m
25mm lens	FoV 13° x 10° (336 x 256) / FoV 25° x 20° (640 x 512) Detection of object 4m x 1.5m: Typical 2200m
35mm lens	FoV 9.3° x 7.1° (336 x 256) / FoV 18° x 14° (640 x 512) Detection of object 4m x 1.5m: Typical 3000m
50mm lens	FoV 6.5° x 5° (336 x 256) / FoV 12.4° x 9.9° (640 x 512) Detection of object 4m x 1.5m: Typical 3900m
100mm lens	FoV 3.3° x 2.5° (336 x 256) / FoV 6.2° x 5.0° (640 x 512) Detection of object 4m x 1.5m: Typical 6000m. Ø102 Germanium housings only

Ordering requirements

The following code is designed to help in selection of the correct unit. Build up the reference number by inserting the code for each component into the appropriate box

XF60														
------	--	--	--	--	--	--	--	--	--	--	--	--	--	--

Housing type	Code
Thermal imaging housing with 50mm germanium window	T
Thermal imaging housing with 102mm germanium window no camera	H

Transmission type	Code
Standard electrical	0
Simplex singlemode 9/125µm video/data	1
Simplex multimode 50/125µm video/data	2
Customer specific transmission device	C

Wiper options	Code
No wiper	N

Temperature type	Code
T4, -20°C to +70°C*	A
T4, -40°C to +70°C*	B
T4, -20°C to +60°C	1
T4, -40°C to +60°C	2
T4, -60°C to +40°C	3
T5, -20°C to +65°C*	C
T5, -40°C to +65°C*	D
T5, -20°C to +60°C*	4
T5, -40°C to +60°C*	5
T5, -60°C to +40°C*	6
T6, -20°C to +40°C*	7
T6, -40°C to +40°C*	8
T6, -60°C to +40°C*	9

Video type	Code
Analogue video	A

Day/night module	Code
No D/N camera fitted	N

Thermal core module	Code
T336 7.5-8.3Hz	8
T640 7.5-8.3Hz	2
T336 25-30Hz	9
T640 25-30Hz	4
Customer specific thermal camera	C

*Subject to configuration restrictions

Thermal core lens	Code
19mm lens	1
25mm lens	2
35mm lens	3
50mm lens	4
100mm lens	5
Customer specific thermal imaging lens	C

Certification	Code
ATEX	A
IECEX	I
INMETRO	M
LCus C1, Z1	U
cLCus C1, D1	Z
cLC CSA	C
TR CU, EAC	R
CCOE	D
CNEX	X
CERTEX	T

Video system	Code
PAL	P
NTSC	N

Protocol requirements	Code
Pelco D protocol, baud rate 2400bps	D
Pelco P protocol, baud rate 4800bps	P
Vicon protocol, baud rate 4800bps	V
HERNISTM protocol	H
Coe protocol	C
Special - price on application	S
No control protocol required	N

Supply voltage	Code
24 VAC ±10% 50/60 Hz	1
110 VAC ±10% 50/60 Hz	2
230 VAC ±10% 50/60 Hz	3
Special - price on application	S

Camera rotation	Code
Not applicable	N