

SF40 thermal image analogue series - UL range

Fixed camera station,
ordinary location



Overview

The Oxalis SF40 thermal imager is a fixed camera housing for use in onshore, offshore, marine and heavy industrial environments where thermal imaging is required for specific process or security applications.

The camera housings are designed specifically for the Americas markets or where UL ordinary location standards have been specified. As a result they utilise NPT entries as standard to maximise compatibility with existing installations.

Our camera stations are designed and manufactured for longevity in harsh environments, require minimal maintenance and are fully certified to UL standards.

See separate datasheets for other global certification ranges.

Features

- Electro-polished 316L stainless steel on all welded assemblies
- Camera station window in toughened glass
- Pole or wall mounting options (see separate datasheets)
- NPT entries as standard
- 5 different size lens options
- 4 resolution/frequency rating options
- Various camera module options
- Options also available for IP, analogue, hybrid, IP over Coax and direct fibre out* - see specific datasheet
- Supply voltage options (24 VAC)
- -58°F to +158°F* operating temperature
- IP66/67

*Model dependent

Specifications

Features	
Sun shield	Standard stainless steel 316L mirror finish
Integral wiper	Optional (silicone wiper blades that are resistant and do not perish after long exposure to ozone, UV, ice, snow, heat or cold)
Integral demister	Standard
Washer systems	Compatible with Oxalis SW washer tanks (see separate datasheets)
Telemetry receiver	Integral - Pelco D, P standard protocols (others to specification)
Analogue direct fibre out	Optional singlemode 9/125µm or multimode 50/125µm video and data fibre optic transmission, mounted inside the camera station
Type approval	DNVGL-CG-0339, 2016 (copper transmission only)
Ingress protection rating	IP66/67
Electrical	
Supply voltage options	24 VAC
Power consumption	37W Maximum (65W with low temperature operation)
Electrical connections	Terminal block for power, data and video specific to camera configuration
Cable entry	2 x ¾" NPT located in rear flange
Mechanical	
Body material	Electro-polished 316L stainless steel on all welded assemblies
Fixings material	A4 stainless steel
Camera station window	Internal AR and external carbon coated germanium Ø50 mm
Mounting options	Pole or wall (see separate datasheets)
Operating temperature	From -58°F to +158°F (model dependent)
Weight (lb)	Up to 20lb depending on configuration
Thermal core module options	
T336 7.5-8.3Hz	Uncooled VOx microbolometer thermal imaging camera, including TCI Interface PCB for functionality over standard RS485 protocol Commands 336 x 256 resolution, 17µ pixel size, 7.5Hz NTSC/8.3Hz PAL exportable frame rate, digital detail enhancement
T640 7.5-8.3Hz	Uncooled VOx microbolometer thermal imaging camera, including TCI Interface PCB for functionality over standard RS485 protocol Commands. 640 x 512 resolution (PAL), 17µ pixel size, 7.5Hz NTSC/8.3Hz PAL exportable frame rate, digital detail enhancement
T336 25-30Hz	Uncooled VOx microbolometer thermal imaging camera, including TCI Interface PCB for functionality over standard RS485 protocol Commands 336 x 256 resolution, 17µ pixel size, 30Hz NTSC/25Hz PAL frame rate, digital detail enhancement. Subject to export restrictions and licensing
T640 25-30Hz	Uncooled VOx microbolometer thermal imaging camera, including TCI Interface PCB for functionality over standard RS485 protocol Commands. 640 x 512 resolution (PAL), 17µ pixel size, 30Hz NTSC/25Hz PAL frame rate, digital detail enhancement. Subject to export restrictions and licensing
Thermal core lens options	
19mm lens	FoV 17° x 13° (336 x 256) / FoV 32° x 26° (640 x 512) Detection of object 4m x 1.5m: Typical 1550m
25mm lens	FoV 13° x 10° (336 x 256) / FoV 25° x 20° (640 x 512) Detection of object 4m x 1.5m: Typical 2200m
35mm lens	FoV 9.3° x 7.1° (336 x 256) / FoV 18° x 14° (640 x 512) Detection of object 4m x 1.5m: Typical 3000m
50mm lens	FoV 6.5° x 5° (336 x 256) / FoV 12.4° x 9.9° (640 x 512) Detection of object 4m x 1.5m: Typical 3900m
100mm lens	FoV 3.3° x 2.5° (336 x 256) / FoV 6.2° x 5.0° (640 x 512) Detection of object 4m x 1.5m: Typical 6000m. Ø90 Germanium housings only

General arrangement drawing (dimensions in inches and mm)

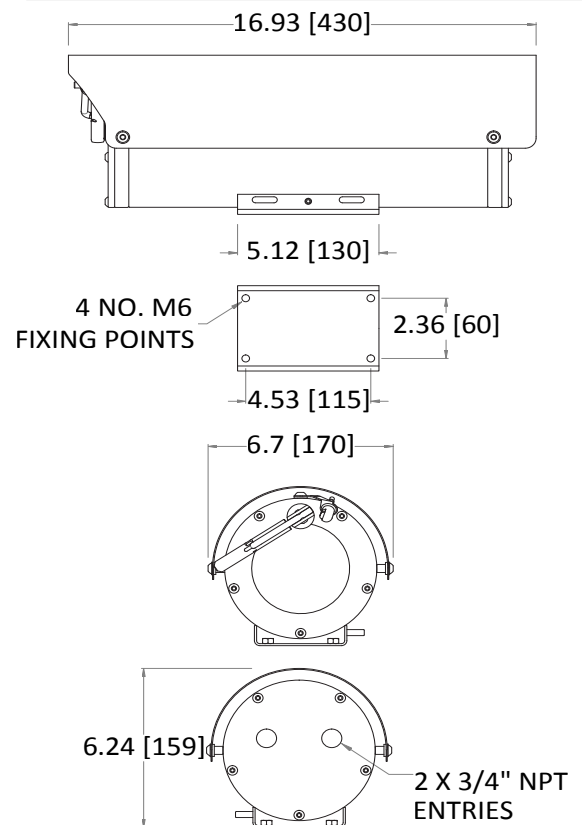

Ordering requirements

The following code is designed to help in selection of the correct unit. Build up the reference number by inserting the code for each component into the appropriate box

SF40													
------	--	--	--	--	--	--	--	--	--	--	--	--	--

Housing type	Code
Thermal imaging housing with 50mm germanium window	H
Thermal imaging housing with 90mm germanium window	T

Wiper options	Code
Integral wiper switched 24VAC for external washer pump	E
No wiper	N

Video type	Code
Analogue video	A

Day/night module	Code
No D/N camera fitted	N

Thermal core module	Code
T336 7.5-8.3Hz	8
T640 7.5-8.3Hz	2
T336 25-30Hz	9
T640 25-30Hz	4
Customer specific thermal camera	C

Thermal core lens	Code
19mm lens	1
25mm lens	2
35mm lens	3
50mm lens	4
100mm lens	5
Customer specific thermal imaging lens	C

Video system	Code
PAL	P
NTSC	N

Supply voltage	Code
24 VAC ±10% 50/60 Hz	1
Special - price on application	S

Camera rotation	Code
Not applicable	N

Protocol requirements	Code
Pelco D protocol, baud rate 2400bps	D
Pelco P protocol, baud rate 4800bps	P
Vicon protocol, baud rate 4800bps	V
HERNIS™ protocol	H
Coe protocol	C
Special - price on application	S
No control protocol required	N

Certification	Code
UL listed	P

Temperature type	Code
-4°F to +158°F	E
-58°F to +158°F	F
-4°F to +122°F	G
-58°F to +122°F	H

Transmission type	Code
Standard electrical	0
Simplex singlemode 9/125µm video/data*	1
Simplex multimode 50/125µm video/data*	2
Customer specific transmission device*	C

*Subject to configuration restrictions