

SP40 thermal image analogue series - UL range

PTZ camera station,
ordinary location



Overview

The Oxalis SP40 thermal imager is a PTZ camera station for use in onshore, offshore, marine and heavy industrial environments.

The camera housings are designed specifically for the Americas markets or where UL ordinary location standards have been specified where thermal imaging is required for specific process or security applications.

The base unit carries dual NPT cable entries with easy access for cable termination during installation as standard, maximising compatibility and ease of use with existing installations.

Our camera stations are designed and manufactured for longevity in harsh environments, require minimal maintenance and are fully certified to UL standards.

See separate datasheets for other global certification ranges.

Features

- Electro-polished 316L stainless steel on all welded assemblies
- Camera station window in toughened glass
- Pole or wall mounting options (see separate datasheets)
- NPT entries as standard
- 5 different size lens options
- 4 resolution/frequency rating options
- Various camera module options
- Options also available for IP, analogue, hybrid, IP over Coax and direct fibre out* - see specific datasheet
- Supply voltage options (24 VAC, 110 or 230 VAC, 50/60Hz)
- -58°F to +158°F* operating temperature
- IP66/67

*Model dependent

Specification

| Features | |
|------------------------------------|---|
| Sun shield | Standard stainless steel 316L mirror finish |
| Integral wiper | Optional (silicone wiper blades that are resistant and do not perish after long exposure to ozone, UV, ice, snow, heat or cold) |
| Integral demister | Standard |
| Washer systems | Compatible with Oxalis SW Washer tanks (see separate datasheets) |
| Pan speed (maximum) | 45° per second |
| Tilt speed (maximum) | 24° per second |
| Pre-set positional accuracy | 64 presets: positional accuracy $\pm 0.1^\circ$ |
| Telemetry receiver | Integral - pelco D, P standard protocols (others to specification) |
| Rotation | Continuous pan or 350° rotation (+/- 175° from straight ahead) |
| Analogue direct fibre out | Optional singlemode 9/125 μm or multimode 50/125 μm video and data fibre optic transmission, mounted inside the camera station |
| Type Approval | DNVGL-CG-0339, 2016 (copper transmission only) |
| Ingress protection rating | IP66/67 |
| Electrical | |
| Supply voltage options | 24 VAC, 110 or 230 VAC, 50/60Hz |
| Power consumption | 85W maximum (143W with low temperature operation) |
| Electrical connections | Terminal block for power, data and video specific to camera configuration |
| Cable entry | 2 x 1/2" NPT located in base |
| Mechanical | |
| Body material | Electro-polished 316L stainless steel on all welded assemblies |
| Fixings material | A4 stainless steel |
| Camera station window | Internal AR and external carbon coated germanium (50 or 90mm \varnothing) |
| Mounting options | Pole or wall (see separate datasheets) |
| Operating temperature | From -58°F to +158°F (model dependent) |
| Weight (lb) | Up to 75lb depending on configuration |
| Thermal core module options | |
| T336 7.5-8.3Hz | Uncooled VOx microbolometer thermal imaging camera, including TCI Interface PCB for functionality over standard RS485 protocol Commands 336 x 256 resolution, 17 μ pixel size, 7.5Hz NTSC/8.3Hz PAL exportable frame rate, digital detail enhancement |
| T640 7.5-8.3Hz | Uncooled VOx microbolometer thermal imaging camera, including TCI Interface PCB for functionality over standard RS485 protocol Commands. 640 x 512 resolution (PAL), 17 μ pixel size, 7.5Hz NTSC/8.3Hz PAL exportable frame rate, digital detail enhancement |
| T336 25-30Hz | Uncooled VOx microbolometer thermal imaging camera, including TCI Interface PCB for functionality over standard RS485 protocol Commands 336 x 256 resolution, 17 μ pixel size, 30Hz NTSC/25Hz PAL frame rate, digital detail enhancement. Subject to export restrictions and licensing |
| T640 25-30Hz | Uncooled VOx microbolometer thermal imaging camera, including TCI Interface PCB for functionality over standard RS485 protocol Commands. 640 x 512 resolution (PAL), 17 μ pixel size, 30Hz NTSC/25Hz PAL frame rate, digital detail enhancement. Subject to export restrictions and licensing |
| Thermal core lens options | |
| 19mm lens | FoV 17° x 13° (336 x 256) / FoV 32° x 26° (640 x 512) Detection of object 4m x 1.5m: Typical 1550m |
| 25mm lens | FoV 13° x 10° (336 x 256) / FoV 25° x 20° (640 x 512) Detection of object 4m x 1.5m: Typical 2200m |
| 35mm lens | FoV 9.3° x 7.1° (336 x 256) / FoV 18° x 14° (640 x 512) Detection of object 4m x 1.5m: Typical 3000m |
| 50mm lens | FoV 6.5° x 5° (336 x 256) / FoV 12.4° x 9.9° (640 x 512) Detection of object 4m x 1.5m: Typical 3900m |
| 100mm lens | FoV 3.3° x 2.5° (336 x 256) / FoV 6.2° x 5.0° (640 x 512) Detection of object 4m x 1.5m: Typical 6000m. $\varnothing 90$ Germanium housings only |

General arrangement drawing (dimensions in inches and mm)

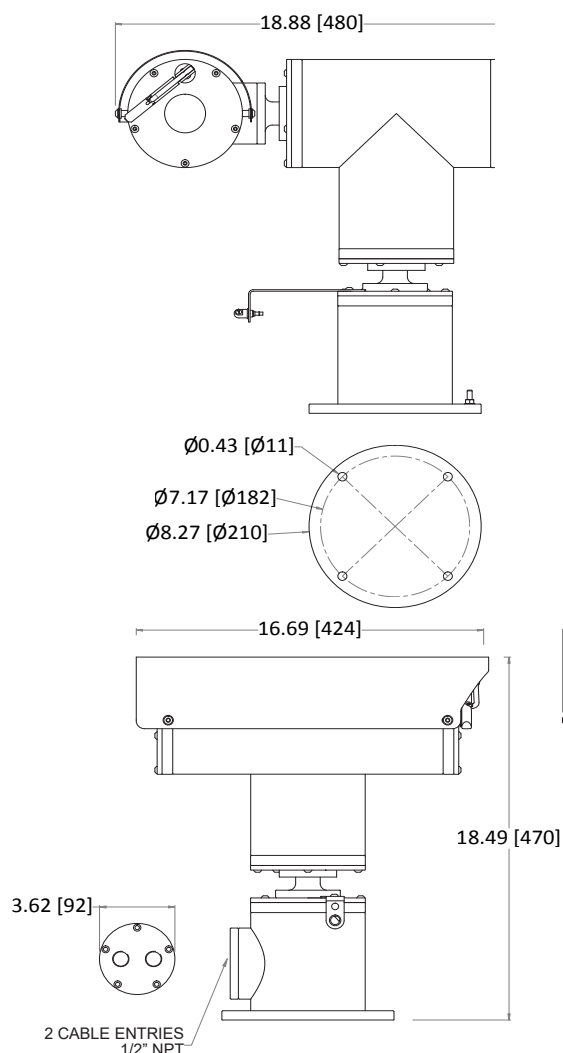

Ordering requirements

The following code is designed to help in selection of the correct unit. Build up the reference number by inserting the code for each component into the appropriate box

