

SP40 HD IP series - UL range

PTZ camera station,
ordinary location



Overview

The Oxalis SP40 is a PTZ camera station for use in onshore, offshore, marine and heavy industrial environments.

The camera housings are designed specifically for the Americas markets or where UL ordinary location standards have been specified.

The base unit carries dual NPT cable entries with easy access for cable termination during installation as standard, maximising compatibility and ease of use with existing installations.

Our camera stations are designed and manufactured for longevity in harsh environments, require minimal maintenance and are fully certified by UL to UL standards.

See separate datasheets for other global certification ranges.

Features

- Electro-polished 316L stainless steel on all welded assemblies
- Camera station window in toughened glass
- Pole or wall mounting options (see separate datasheets)
- NPT entries as standard
- Various camera module options
- Options also available for IP, analogue, hybrid, IP over Coax and direct fibre out* - see specific datasheet
- Supply voltage options (24 VAC, 110 or 230 VAC, 50/60Hz)
- -58°F to +158°F* operating temperature
- IP66/67

*Model dependent

Specification

Features	
Sun shield	Standard stainless steel 316L mirror finish
Integral wiper	Optional (silicone wiper blades that are resistant and do not perish after long exposure to ozone, UV, ice, snow, heat or cold)
Integral demister	Standard
Washer systems	Compatible with Oxalis SW Washer tanks (see separate datasheets)
Pan speed (maximum)	45° per second
Tilt speed (maximum)	24° per second
Pre-set positional accuracy	64 presets: positional accuracy $\pm 0.1^\circ$
Telemetry receiver	Integral - Pelco D standard protocol (others to specification)
Rotation	Continuous pan or 350° rotation (+/- 175° from straight ahead)
IP direct fibre out	Optional integrated media converter, Simplex/Duplex Singlemode 9/125 μ m or Multimode 50/125 μ m, 10/100Mb Ethernet, IEEE 802.3
IP over coax	Optional integrated IP ethernet-over-coax converter (must be used with compatible Rx equipment)
Type approval	DNVGL-CG-0339, 2016 (copper transmission only)
Ingress protection rating	IP66/67

Electrical	
Supply voltage options	24 VAC, 110 or 230 VAC, 50/60Hz
Power consumption	85W maximum (143W with low temperature operation)
Electrical connections	Terminal block for power, data and video specific to camera configuration
Cable entry	2 x 1/2" NPT located in base
Mechanical	
Body material	Electro-polished 316L stainless steel on all welded assemblies
Fixings material	A4 stainless steel
Camera station window	Toughened glass
Mounting options	Pole or wall (see separate datasheets)
Operating temperature	From -58°F to +158°F (model dependent)
Weight	Up to 75lb depending on configuration

Camera options

32x XNZ-6320 HP IP camera		22x zoom 3MP HD IP camera	
Image sensor	Progressive scan CMOS 1/2.8"	Image sensor	Progressive scan CMOS 1/2.8"
Resolution	Resolution: 1920x1080 @60fps to 320x240	Resolution	2304 x 1296 @ 30fps
Lens	32x optical 32x digital zoom 4.44-142.6 mm F1.6 to F4.4, horizontal angle of view 61.8° - 2.19°	Lens	22x optical zoom 5.2~114.4mm F1.5~F3.8, horizontal angle of view 53.74° - 2.96°
Min. illumination	Colour : 0.05Lux (1/30sec, F1.6, 50IRE), B/W : 0.005Lux (1/30sec, F1.6, 50IRE)	Min. illumination	Colour : 0.002Lux (F1.5, AGC ON), B/W 0.001Lux (F1.5, AGC ON)
Streaming	H.264, H.265 MJPEG dual codec, multiple streaming, VBR/CBR	Streaming	Triple streams in H.264, H.265
Features	Intelligent video analytics, motion detection, day & night (ICR), WDR (150dB), auto focus, auto Iris, AGC, SSSDR, ATW, SSSNR III, BLC, DIS, Defog	Features	AGC, AE,AWB,TDN,DNR,BLC,EIS,WDR,Defog,OSD,Day & Night Auto Colour/BW (IR-cut with auto switch)
Standards protocols	ONVIF Profile S, TCP/IP, UDP/IP, RTP(UDP), RTP(TCP), RTCP, RTSP, NTP, HTTP, HTTPS, SSL, DHCP, FTP, SMTP, ICMP, IGMP, SNMPv1/v2c/v3(MIB-2), ARP, DNS, DDNS, QoS, PIM-SM, UPnP, Bonjour	Standards protocols	L2TP, IPv4, IGMP, ICMP, ARP, TCP, UDP, DHCP, PPPoE, RTP, RTSP, DNS, DDNS, NTP, FTP, UPnP, HTTP, SNMP, SIP
33x zoom 3MP HD IP camera		22x zoom 5MP HD IP camera	
Image Sensor	Progressive scan CMOS 1/2.8"	Image Sensor	Progressive scan CMOS 1/2.7"
Resolution	2304 x 1296 @ 60fps	Resolution	2880 x 1620 @ 30fps
Lens	33x optical zoom 4.5~148.5mm F1.5~F4.0, horizontal angle of view 62.93° - 3.67°	Lens	22x optical zoom 5.2~114.4mm F1.5~F3.8, horizontal angle of view 55.46° - 3.09°
Min. illumination	Colour : 0.001Lux (F1.5, AGC ON), B/W 0.0005Lux (F1.5, AGC ON)	Min. illumination	Colour : 0.003Lux (F1.5, AGC ON), B/W 0.001Lux (F1.5, AGC ON)
Streaming	Five streams in H.264, H.265	Streaming	Triple streams in H.264, H.265
Features	AGC, AE,AWB,TDN,DNR,BLC,EIS,WDR,Defog,OSD,Day & Night Auto Colour/BW (IR-cut with auto switch)	Features	AGC, AE,AWB,TDN,DNR,BLC,EIS,WDR,Defog,OSD,Day & Night Auto Colour/BW (IR-cut with auto switch)
Standards Protocols	L2TP, IPv4, IGMP, ICMP, ARP, TCP, UDP, DHCP, PPPoE, RTP, RTSP, DNS, DDNS, NTP, FTP, UPnP, HTTP, SNMP, SIP	Standards Protocols	L2TP, IPv4, IGMP, ICMP, ARP, TCP, UDP, DHCP, PPPoE, RTP, RTSP, DNS, DDNS, NTP, FTP, UPnP, HTTP, SNMP, SIP

General arrangement drawing (dimensions in inches and mm)

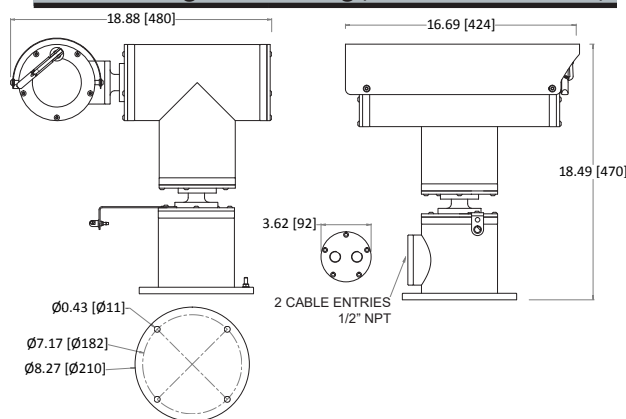

Ordering requirements

The following code is designed to help in selection of the correct unit. Build up the reference number by inserting the code for each component into the appropriate box

