

# XF40 day/night HD IP series - UL range

Fixed camera station,  
hazardous location



## Overview

The Oxalis XF40 is an explosion protected fixed camera housing for use in hazardous areas in onshore, offshore, marine and heavy industrial environments.

The camera housings are designed specifically for the Americas markets or where UL standards on Class and Division have been specified. As a result they utilise NPT entries as standard to maximise compatibility with existing fixed conduit installations.

Our camera stations are designed and manufactured for longevity in harsh environments, require minimal maintenance and are fully certified to UL standards as required by OSHA in both safe and hazardous areas.

See separate datasheet for ATEX/IECEX & other zone certification ranges.

## Features

- Class 1 Division 1 and Zone 1 certified
- Electro-polished 316L stainless steel on all welded assemblies
- Camera station window in toughened glass
- Pole or wall mounting options (see separate datasheets)
- NPT entries as standard
- Various camera module options
- Options also available for IP, analogue, hybrid, IP over Coax and direct fibre out\* - see specific data sheet
- Supply voltage options (24 VAC)
- Certified temperature from -58°F to +158°F\* (ranging from T4 - T6)
- IP66/67

\*Model dependent

## Certifications

UL C1/D1	Class I, Division 1, Groups B, C, D, T4+ -50°C to +70°C (-58°F to +158°F)
	Class II, Division 1, Groups E, F, G IP67
	Class 1 Zone 1 A Ex d IIB + Hydrogen T4 (T5 On Request)
	On Request: T5 -50°C to +70°C (-58°F to +158°F), T6 -50°C to +50°C (-58°F to +122°F)
UL Listing: E477542	

## General arrangement drawing (dimensions in inches and mm)

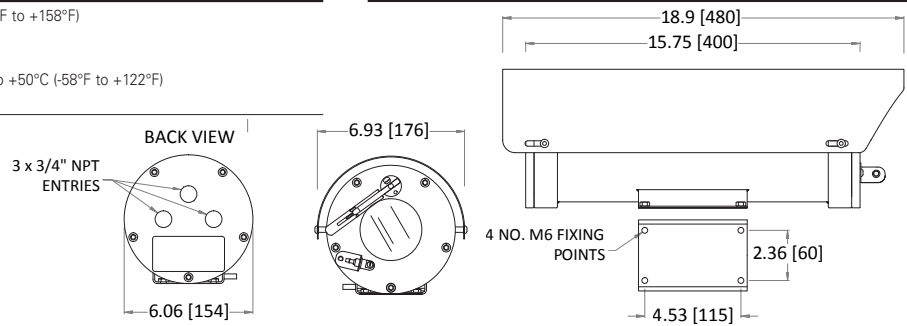

## Specifications

**Certification part number** Housing options OXALIS-UL2410-03, 1410-10, 1410-15

Features		Electrical	
<b>Sun shield</b>	Standard stainless steel 316L mirror finish	<b>Supply voltage options</b>	24 VAC
<b>Integral wiper</b>	Optional (silicone wiper blades that are resistant and do not perish after long exposure to ozone, UV, ice, snow, heat or cold)	<b>Power consumption</b>	37W maximum (65W with low temperature operation)
<b>Integral demister</b>	Standard	<b>Electrical connections</b>	Terminal block for power, data and video specific to camera configuration
<b>Washer systems</b>	Compatible with Oxalis XW or XWP washer tanks (see datasheets)	<b>Cable entry</b>	3 x 3/4" NPT located in rear flange
<b>Telemetry receiver</b>	Integral - Pelco D standard protocol (others to specification)	<b>Mechanical</b>	
<b>IP direct fibre out options</b>	Optional integrated media converter, simplex/duplex singlemode 9/125µm or multimode 50/125µm, 10/100Mb Ethernet, IEEE 802.3	<b>Body material</b>	Electro-polished 316L stainless steel on all welded assemblies
<b>IP over coax</b>	Optional integrated IP Ethernet-over-coax converter (must be used with compatible Rx equipment)	<b>Fixings material</b>	A4 stainless steel
<b>Type approval</b>	DNVGL-CG-0339, 2016 (copper transmission only)	<b>Camera station window</b>	Toughened glass
<b>Ingress protection rating</b>	IP66/67, IP68 (1.5m for 24 hours)	<b>Mounting options</b>	Pole or wall (see separate datasheets)
		<b>Operating temperature</b>	From -58°F to +158°F (model dependent)
		<b>Weight (lb)</b>	Up to 33lb depending on configuration

### Camera options

32x XN2-6320 HP IP camera		22x zoom 3MP HD IP camera	
<b>Image sensor</b>	Progressive scan CMOS 1/2.8"	<b>Image sensor</b>	Progressive scan CMOS 1/2.8"
<b>Resolution</b>	Resolution: 1920x1080 @60fps to 320x240	<b>Resolution</b>	2304 x 1296 @ 30fps
<b>Lens</b>	32x optical 32x digital zoom 4.44-142.6 mm F1.6 to F4.4, horizontal angle of view 61.8° - 2.19°	<b>Lens</b>	22x optical zoom 5.2~114.4mm F1.5~F3.8, horizontal angle of view 53.74° - 2.96°
<b>Min. illumination</b>	Colour : 0.05Lux (1/30sec, F1.6, 50IRE), B/W : 0.005Lux (1/30sec, F1.6, 50IRE)	<b>Min. illumination</b>	Colour : 0.002Lux (F1.5, AGC ON), B/W 0.001Lux (F1.5, AGC ON)
<b>Streaming</b>	H.264, H.265 MJPEG dual codec, multiple streaming, VBR/CBR	<b>Streaming</b>	Triple streams in H.264, H.265
<b>Features</b>	Intelligent video analytics, motion detection, day & night (ICRI), WDR (150dB), auto focus, auto Iris, AGC, SDR, ATW, SSNR III, BLC, DIS, Defog	<b>Features</b>	AGC, AE,AWB,TDN,DNR,BLC,EIS,WDR,Defog,OSD,Day & Night Auto Colour/BW (IR-cut with auto switch)
<b>Standards protocols</b>	ONVIF Profile S, TCP/IP, UDP/IP, RTP(UDP), RTP(TCP), RTCP, RTSP, NTP, HTTP, HTTPS, SSL, DHCP, FTP, SMTP, ICMP, IGMP, SNMPv1/v2c/v3(MIB-2), ARP, DNS, DDNS, QoS, PIM-SM, UPnP, Bonjour	<b>Standards protocols</b>	L2TP, IPv4, IGMP, ICMP, ARP, TCP, UDP, DHCP, PPPoE, RTP, RTSP, DNS, DDNS, NTP, FTP, UPnP, HTTP, SNMP, SIP
33x zoom 3MP HD IP camera		22x zoom 5MP HD IP camera	
<b>Image Sensor</b>	Progressive scan CMOS 1/2.8"	<b>Image Sensor</b>	Progressive scan CMOS 1/2.7"
<b>Resolution</b>	2304 x 1296 @ 60fps	<b>Resolution</b>	2880 x 1620 @ 30fps
<b>Lens</b>	33x optical zoom 4.5~148.5mm F1.5~F4.0, horizontal angle of view 62.93° - 3.67°	<b>Lens</b>	22x optical zoom 5.2~114.4mm F1.5~F3.8, horizontal angle of view 55.46° - 3.09°
<b>Min. Illumination</b>	Colour : 0.001Lux (F1.5, AGC ON), B/W 0.0005Lux (F1.5, AGC ON)	<b>Min. Illumination</b>	Colour : 0.003Lux (F1.5, AGC ON), B/W 0.001Lux (F1.5, AGC ON)
<b>Streaming</b>	Five streams in H.264, H.265	<b>Streaming</b>	Triple streams in H.264, H.265
<b>Features</b>	AGC, AE,AWB,TDN,DNR,BLC,EIS,WDR,Defog,OSD,Day & Night Auto Colour/BW (IR-cut with auto switch)	<b>Features</b>	AGC, AE,AWB,TDN,DNR,BLC,EIS,WDR,Defog,OSD,Day & Night Auto Colour/BW (IR-cut with auto switch)
<b>Standards Protocols</b>	L2TP, IPv4, IGMP, ICMP, ARP, TCP, UDP, DHCP, PPPoE, RTP, RTSP, DNS, DDNS, NTP, FTP, UPnP, HTTP, SNMP, SIP	<b>Standards Protocols</b>	L2TP, IPv4, IGMP, ICMP, ARP, TCP, UDP, DHCP, PPPoE, RTP, RTSP, DNS, DDNS, NTP, FTP, UPnP, HTTP, SNMP, SIP

# Ordering requirements

The following code is designed to help in selection of the correct unit. Build up the reference number by inserting the code for each component into the appropriate box

XF40

Housing type	Code
Visual camera housing	V

Wiper options	Code
Integral wiper with switched 24VAC for external washer pump	E
No wiper	N

Video type	Code
IP	I

Day/night module	Code
32x zoom 2MP HD IP camera	P
22x zoom 3MP HD IP camera	U
33x zoom 3MP HD IP camera	V
22x zoom 5MP HD IP camera	W

Thermal core module	Code
No thermal core	N

Thermal core lens	Code
No thermal imaging lens	N

Video system	Code
IP	I

Camera rotation	Code
Not applicable	N

Supply voltage	Code
24 VAC ±10% 50/60 Hz	1
Special - price on application	S

Transmission type	Code
Standard electrical	0
Simplex singlemode 9/125µm ethernet*	3
Simplex multimode 50/125µm ethernet*	4
IP over coax*	5
Duplex singlemode 9/125µm*	6
Duplex Multimode 50/125µm*	7
Customer specific fibre transmission device*	C

\*Subject to configuration restrictions

Temperature type	Code
T4A -4°F to +158°F	E
T4A -58°F to +158°F	F
T6 -4°F to +122°F*	G
T6 -58°F to +122°F*	H

\*Subject to restrictions

Certification	Code
UL Class I Div I	L

Protocol requirements	Code
Pelco D protocol, baud rate 2400bps	D
HERNIS™ protocol	H
Special - price on application	S