

XF60 thermal image analogue series - UL range

Fixed camera station,
hazardous location



Overview

The Oxalis XF60 thermal imager is an explosion protected fixed camera housing for use in hazardous areas in onshore, offshore, marine and heavy industrial environments where thermal imaging is required for specific process or security applications. The large format housing allows the installation of customised equipment (subject to conformity).

The camera housings are designed specifically for the Americas markets or where UL standards on Class and Division have been specified. As a result they utilise NPT entries as standard to maximise compatibility with existing fixed conduit installations.

Our camera stations are designed and manufactured for longevity in harsh environments, require minimal maintenance and are fully certified to UL standards as required by OSHA in both safe and hazardous areas.

See separate datasheet for ATEX/IECEX & other zone certification ranges.

Features

- Class 1 Division 1 and Zone 1 certified
- Electro-polished 316L stainless steel on all welded assemblies
- Camera station window in toughened glass
- Pole or wall mounting options (see separate datasheets)
- NPT entries as standard
- 5 different size lens options
- 4 resolution/frequency rating options
- Various camera module options
- Options also available for IP, analogue, hybrid, IP over Coax and direct fibre out* - see specific data sheet
- Supply voltage options (24 VAC, 110 or 230 VAC, 50/60Hz)
- Certified temperature from -58°F to +158°F* (ranging from T4 - T6)
- IP66/67

*Model dependent

Certifications

UL CI/DI	Class I, Division 1, Groups B, C, D, T4+ -50°C to +70°C (-58°F to +158°F)
	Class II, Division 1, Groups E, F, G IP67
	Class 1 Zone 1 A Ex d IIB + Hydrogen T4 (T5 On Request)
	On Request: T5 -50°C to +70°C (-58°F to +158°F), T6 -50°C to +50°C (-58°F to +122°F)
UL Listing: E477542	

General arrangement drawing (dimensions in inches and mm)

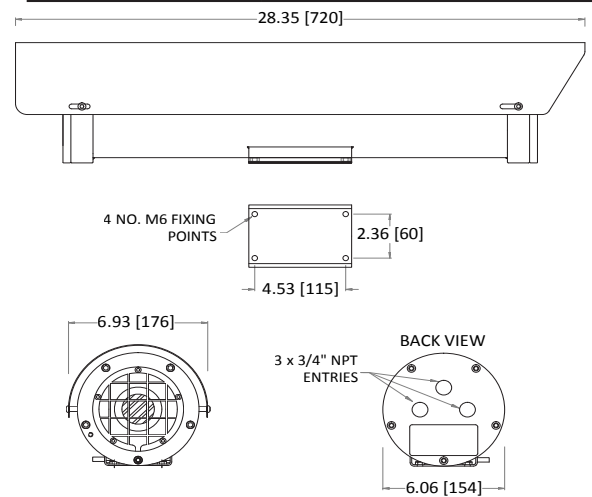

Specifications

Certification part number	Housing options OXALIS-UL2410-TI, 2410-TI-50
Features	
Sun shield	Standard stainless steel 316L mirror finish
Integral demister	Standard
Telemetry receiver	Integral - Pelco D, P standard protocols (others to specification)
Analogue direct fibre out	Optional singlemode 9/125µm or multimode 50/125µm video and data fibre optic transmission, mounted inside the camera station
Electrical	
Supply voltage options	24 VAC, 110 or 230 VAC, 50/60Hz
Power consumption	37W maximum (65W with low temperature operation)
Electrical connections	Terminal block for power, data and video specific to camera configuration
Cable entry	3 x 3/4" NPT located in rear flange
Type approval	DNVGL-CG-0339, 2016 (copper transmission only)
Ingress protection rating	IP66/67, IP68 (1.5m for 24 hours)
Mechanical	
Body material	Electro-polished 316L stainless steel on all welded assemblies
Fixings material	A4 stainless steel
Camera station window	Internal AR and external carbon coated germanium (50 or 102mm Ø) with protective grill
Mounting options	Pole or wall (see separate datasheets)
Operating temperature	From -58°F to +158°F (model dependent)
Weight (lb)	Up to 40lb depending on configuration
Thermal core module options	
T336 7.5-8.3Hz	Uncooled VOx microbolometer thermal imaging camera, including TCI Interface PCB for functionality over standard RS485 protocol Commands 336 x 256 resolution, 17µ pixel size, 7.5Hz NTSC/8.3Hz PAL exportable frame rate, digital detail enhancement
T640 7.5-8.3Hz	Uncooled VOx microbolometer thermal imaging camera, including TCI Interface PCB for functionality over standard RS485 protocol Commands 640 x 512 resolution (PAL), 17µ pixel size, 7.5Hz NTSC/8.3Hz PAL exportable frame rate, digital detail enhancement
T336 25-30Hz	Uncooled VOx microbolometer thermal imaging camera, including TCI Interface PCB for functionality over standard RS485 protocol Commands 336 x 256 resolution, 17µ pixel size, 30Hz NTSC/25Hz PAL frame rate, digital detail enhancement. Subject to export restrictions and licensing
T640 25-30Hz	Uncooled VOx microbolometer thermal imaging camera, including TCI Interface PCB for functionality over standard RS485 protocol Commands 640 x 512 resolution (PAL), 17µ pixel size, 30Hz NTSC/25Hz PAL frame rate, digital detail enhancement. Subject to export restrictions and licensing
Thermal core lens options	
19mm lens	FoV 17° x 13° (336 x 256) / FoV 32° x 26° (640 x 512) Detection of object 4m x 1.5m: Typical 1550m
25mm lens	FoV 13° x 10° (336 x 256) / FoV 25° x 20° (640 x 512) Detection of object 4m x 1.5m: Typical 2200m
35mm lens	FoV 9.3° x 7.1° (336 x 256) / FoV 18° x 14° (640 x 512) Detection of object 4m x 1.5m: Typical 3000m
50mm lens	FoV 6.5° x 5° (336 x 256) / FoV 12.4° x 9.9° (640 x 512) Detection of object 4m x 1.5m: Typical 3900m
100mm lens	FoV 3.3° x 2.5° (336 x 256) / FoV 6.2° x 5.0° (640 x 512) Detection of object 4m x 1.5m: Typical 6000m. Ø102 Germanium housings only

Ordering requirements

The following code is designed to help in selection of the correct unit. Build up the reference number by inserting the code for each component into the appropriate box

XF60

Housing type	Code
Thermal imaging housing with 50mm germanium window	T
Thermal imaging housing with 102mm germanium window no camera	H

Wiper options	Code
No wiper	N

Video type	Code
Analogue video	A

Day/night module	Code
No D/N camera fitted	N

Thermal core module	Code
T336 7.5-8.3Hz	8
T640 7.5-8.3Hz	2
T336 25-30Hz	9
T640 25-30Hz	4
Customer specific thermal camera	C

Thermal core lens	Code
19mm lens	1
25mm lens	2
35mm lens	3
50mm lens	4
100mm lens	5
Customer specific thermal imaging lens	C

Video system	Code
PAL	P
NTSC	N

Transmission type	Code
Standard electrical	0
Simplex singlemode 9/125µm video/data	1
Simplex multimode 50/125µm video/data	2
Customer specific transmission device	C

Temperature type	Code
T4A -4°F to +158°F	E
T4A -58°F to +158°F	F
T6 -4°F to +122°F*	G
T6 -58°F to +122°F*	H

*Subject to restrictions

Certification	Code
UL Class I Div I	L

Protocol requirements	Code
Pelco D protocol, baud rate 2400bps	D
Pelco P protocol, baud rate 4800bps	P
Vicon protocol, baud rate 4800bps	V
HERNISTM protocol	H
Coe protocol	C
Special - price on application	S
No control protocol required	N

Camera rotation	Code
Not applicable	N

Supply voltage	Code
24 VAC ±10% 50/60 Hz	1
110 VAC ±10% 50/60 Hz	2
230 VAC ±10% 50/60 Hz	3
Special - price on application	S