

Vickers®

Service Data

Vane Pumps



Vane Type Double Pump

4520VQ Series - 20 Design



Revised 10-01-89

I-3170-S

MODEL	COVER TYPE	COVER S/A
4520VQ**A**(*)-***20(*)	4-BOLT	250824
4520VQ**E**(*)-***20(*)	STRAIGHT THREAD	252504
4520VQ**E**(*)-***2*20(*)	FLOW CONTROL	257560
4520VQ**E**(*)-***4*20(*)		257561
4520VQ**E**(*)-***6*20(*)		257562
4520VQ**E**(*)-***7*20(*)		257563
4520VQ**E**(*)-***8*20(*)		257564
4520VQ**E**(*)-***10*20(*)		257565
4520VQ**E**(*)-***12*20(*)		257999

MODEL	RELIEF VALVE SETTING (PSI)	RELIEF VALVE S/A
4520VQ***(*)-***C 20(*)	750	232794
4520VQ***(*)-***D 20(*)	1000	232795
4520VQ***(*)-***E 20(*)	1250	232796
4520VQ***(*)-***F 20(*)	1500	232797
4520VQ***(*)-***G 20(*)	1750	232798
4520VQ***(*)-***H 20(*)	2000	232799
4520VQ***(*)-***J 20(*)	2250	233019
4520VQ***(*)-***K 20(*)	2500	233020

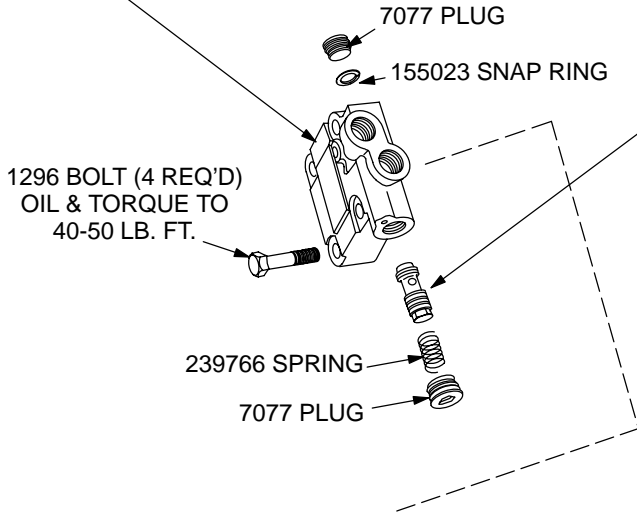

☐ WIPE O.D. OF SEAL WITH OIL BEFORE PRESSING INTO BODY. APPLY GREASE TO SEAL I.D. BEFORE INSTALLATION OF SHAFT.

***NOTE**
INSTALL INTO COVER BEFORE INSTALLATION OF CARTRIDGE KIT.

416426 SCREW (2 REQ'D)
TORQUE TO 30 ± 5 LB. IN.

87947 BOLT (4 REQ'D)
OIL & TORQUE TO 255 - 275 LB. FT

252283 INLET BODY

422206 PIN (2 REQ'D)

NOTE
BRONZE FACES MUST BE INSTALLED TOWARD THE ROTOR.

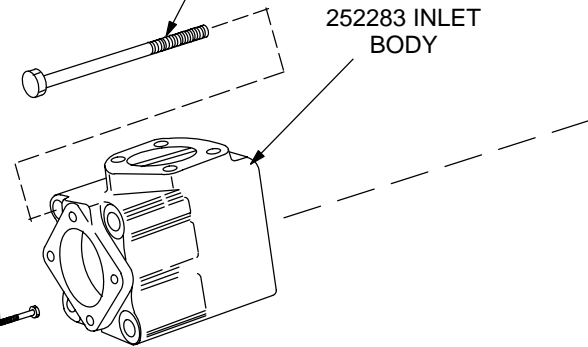

MODEL	▲ BACK-UP RING	▲ "O" RING	▲ SEAL RING	▲ "O" RING	OUTLET SUPPORT PLATE	▲ SEAL PACK (4 REQ'D)	■ FLEX-SIDE PLATE KIT	ROTOR	VANE KIT (10 VANES & 10 INSERTS)	RING	INLET SUPPORT PLATE	CART. KIT	F3 CART. KIT							
THESE PARTS ARE INCLUDED IN CARTRIDGE KIT																				
4520VQ*** 5*(*)	588506	154026	419672	154090	419500	433762 S/A	923955	402690	922741	333624	419502	417053	421588							
4520VQ*** 8*(*)										333625				421589						
4520VQ*** 9*(*)																374799		423096	423097	
4520VQ*** 11*(*)															403539	922743	333626	419501	416427	421590
4520VQ*** 12*(*)														353901			416428		421591	
4520VQ*** 14*(*)							353902	416429	421592											

● ASSEMBLE SEAL FLUSH TO PILOT FACE WITH SPRING FACING INWARD AS SHOWN.

○ ASSEMBLE SEAL WITH SPRING TOWARD BEARING.

MOUNTING ASSEMBLY 4520VQ**A**F-***-20(*)		
INCLUDED IN FOOT BRACKET KIT NO.	SCREW (2 REQ'D)	MOUNTING BRACKET
FB-C-10	205533	205077

SHAFT NO.	TYPE	SHAFT P/N	SEC. SHAFT SEAL	KEY
1	STR. KEYED	255533	—	217596
11	SPLINE	255536	—	—
86	STR. KEYED HEAVY DUTY	361761	—	239751
114	SPLINE	413436	429282	—
130	SPLINE	432702	429282	—

△●○ SECONDARY SHAFT SEAL (SEE TABLE) (USE ON 'S' FLANGE MOUNTED MODELS ONLY.)

▲□○ 394974
PRIMARY SHAFT SEAL

194878 WASHER

942356 BODY S/A

SCREW (SEE TABLE)

NOTE
BRONZE FACES MUST BE INSTALLED TOWARD THE ROTOR.

131812 BEARING

102949 RETAINING RING
158630 SPIROLOX RING

TORQUE TO
100 LB. IN.

STD/F3 SEAL KITS			
▲ STD SINGLE SHAFT	△▲ STD DOUBLE- SHAFT	▲ F3 SINGLE SHAFT	△▲ F3 DOUBLE SHAFT
920060	920061	920062	920063

MODEL	SCREW (2 REQ'D)	PIN (2 REQ'D)	INLET SUPPORT PLATE	▲ SEAL PACK (4 REQ'D)	◆ FLEX- SIDE- PLATE KIT	ROTOR	VANE KIT (10 VANES & 10 INSERTS)	RING	OUTLET SUPPORT PLATE	■▲ "O" RING	*■▲ SEAL RING	▲ "O" RING	■▲ BACK-UP RING	CART. KIT	F3 CART. KIT
THESE PARTS ARE INCLUDED IN CARTRIDGE KIT															
4520VQ42A								295710						416435	419511
4520VQ47A								297718						421234	421954
4520VQ50A	380109	422208	430807 S/A	433768 S/A	923954	283871	922701	297502	425510	154107	419675	154087	588509	416436	419510
4520VQ57A								306772						421233	421955
4520VQ60A								297503						416437	419509

*INSTALL SEAL RING IN BODY OR COVER, THEN INSTALL CARTRIDGE KIT

■ **NOTE:** FLEX SIDEPLATE KITS INCLUDE (4) F3 SEAL PACKS.

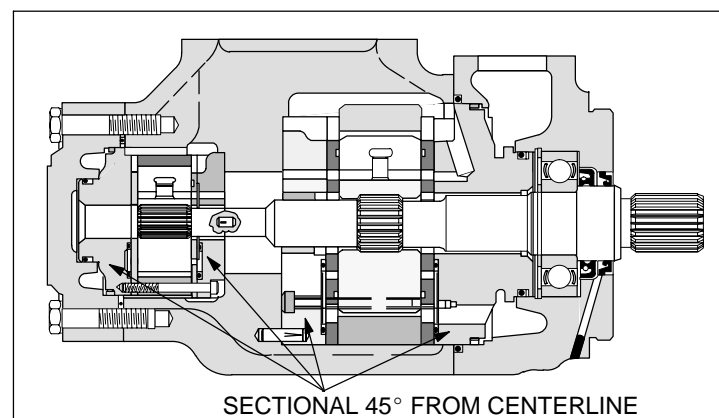

SECTIONAL 45° FROM CENTERLINE

Model Code

(F3) - 4520 VQ ** A ** - * 1 ** ** * 20 (*) - 28 *

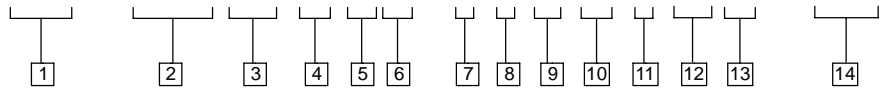

1 F3 – Viton seals
(Omit if not required.)
F10 – Viton shaft seals

2 Series designation

3 Intra-vane pump

4 USgpm capacity
(Shaft end pump)

SAE rating 1200 rpm–100 psi (7 bar)

42 – 42 USgpm	57 – 57 USgpm
47 – 47 USgpm	60 – 60 USgpm
50 – 50 USgpm	

5 SAE port connections

Models Without Flow Control

Code	Inlet	Outlet #1	Outlet #2
A –	4 bolt flange	4 bolt flange	4 bolt flange
E –	4 bolt flange	4 bolt flange	SAE St. Thd.

Models With Flow Control

Code	Inlet	Outlet #1	Outlet #2	Tank Return
A –	4 bolt flange	4 bolt flange	SAE St. Thd.	SAE St. Thd.

6 USgpm capacity
(Cover end pump)

SAE rating 1200 rpm–100 psi (7 bar)

5 – 5 USgpm	11 – 11 USgpm
8 – 8 USgpm	12 – 12 USgpm
9 – 9 USgpm	14 – 14 USgpm

7 Mounting

F – Foot (Single shaft seal)
S – Flange (Double shaft seal)
Omitted – Flange, single shaft seal assembly

8 Shaft type

1– Straight with square key standard
11– Splined
19– Splined
33– Splined
86– Straight keyed, heavy duty

9 Outlet port positions
(Viewed from cover end of pump)

With # 1 outlet opposite inlet:
AA – # 2 outlet – 135° CCW from inlet
AB – # 2 outlet – 45° CCW from inlet
AC – # 2 outlet – 45° CW from inlet
AD – # 2 outlet – 135° CW from inlet

With # 1 outlet 90° CCW from inlet:
BA – # 2 outlet – 135° CCW from inlet
BB – # 2 outlet – 45° CCW from inlet
BC – # 2 outlet – 45° CW from inlet
BD – # 2 outlet – 135° CW from inlet

9 Outlet port positions continued
(Viewed from cover end of pump)

With # 1 outlet inline with inlet:
CA – # 2 outlet – 135° CCW from inlet
CB – # 2 outlet – 45° CCW from inlet
CC – # 2 outlet – 45° CW from inlet
CD – # 2 outlet – 135° CW from inlet

With # 1 outlet 90° CW from inlet:
DA – # 2 outlet – 135° CCW from inlet
DB – # 2 outlet – 45° CCW from inlet
DC – # 2 outlet – 45° CW from inlet
DD – # 2 outlet – 135° CW from inlet

10 Controlled flow rate
(Models with flow control)

2 – 2 USgpm	8 – 8 USgpm
4 – 4 USgpm	10 – 10 USgpm
6 – 6 USgpm	12 – 12 USgpm
7 – 7 USgpm	

11 Relief valve setting
(Models with flow control)

C – 750 PSI	G – 1750 PSI
D – 1000 PSI	H – 2000 PSI
E – 1250 PSI	I – 2250 PSI
F – 1500 PSI	J – 2500 PSI*

* 20V pump only (not for 12 & 14 ring sizes).

12 Design

13 Rotation
(Viewed from shaft end of pump)

L – Left hand (CCW rotation)
Omitted – Right hand rotation

14 Mounting

282 – SAE 2-bolt mounting
283 – Foot mounting

NOTE

Standard right hand shaft rotation cartridges shown. Reverse for left hand rotation; refer to note.

Cover end cartridge R. H. Rotation

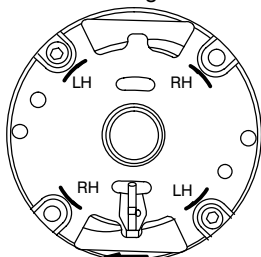

Sharp Edges of Vane Must Lead in Direction of Rotation

Shaft end cartridge R. H. Rotation

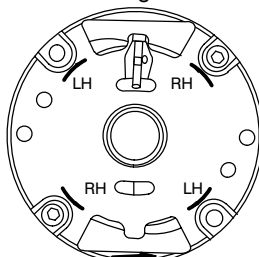

Sharp Edges of Vane Must Lead in Direction of Rotation

NOTE

To reverse cartridge kit rotation, remove the two screws and reverse the location of the inlet support plate and the outlet support plate. Reinstall the two screws hand tight. Use pump cover to align all sections of the cartridge. Carefully remove the cover and tighten the screws.

NOTE

For satisfactory service life of these components, use full flow filtration to provide fluid which meets ISO cleanliness code 16/13 or cleaner. Selections from pressure, return, and in-line filter series are recommended.