

Service Data

Vickers®

Vane Pumps



Vane Type Double Pump

(F3)–4520V(M)–**A(M)**(F)–**–22–*

MODEL	■ ROTOR	■ VANE KIT	■ RING	■ INLET PLATE	Cover End	Cover End
					■ CART. KIT	■ F3 CART. KIT
4520V***2	402690	02-136720	388683	584383	02-102506	02-102512
4520V***5			333624		02-102507	02-102513
4520V***8			333625		02-102508	02-102514
4520V***11	403539	02-136721	333626	584384	02-102509	02-102515
4520V***12			353901		02-102510	02-102516
4520V***14			353902		02-102511	02-102517

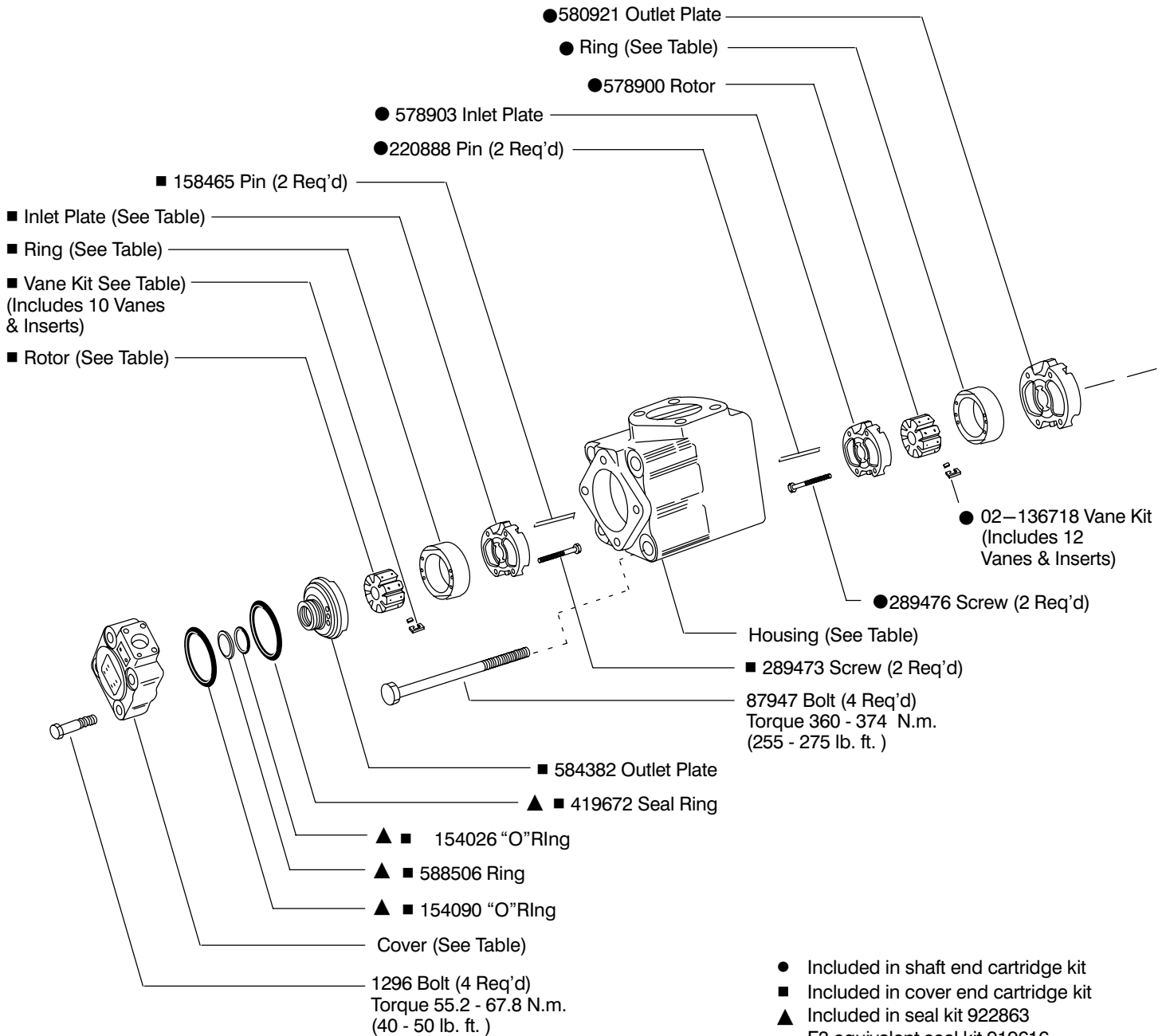

- Included in shaft end cartridge kit
- Included in cover end cartridge kit
- ▲ Included in seal kit 922863
- ▲ F3 equivalent seal kit 919616
- ◇ Included in foot bracket kit FB-C-10
- Assemble seal with spring loaded sealing member towards bearing. Seals to be completely wetted with oil prior to assembly.
- * Install 419675 sealing ring into body, then install cartridge kit.

MODEL	● RING	Shaft End ● CART KIT	Shaft End ● F3 CART KIT
4520V42	581679	02-102572	02-102576
4520V45	582570	02-102573	02-102593
4520V50	581680	02-102574	02-102577
4520V60	578904	02-102575	02-102578

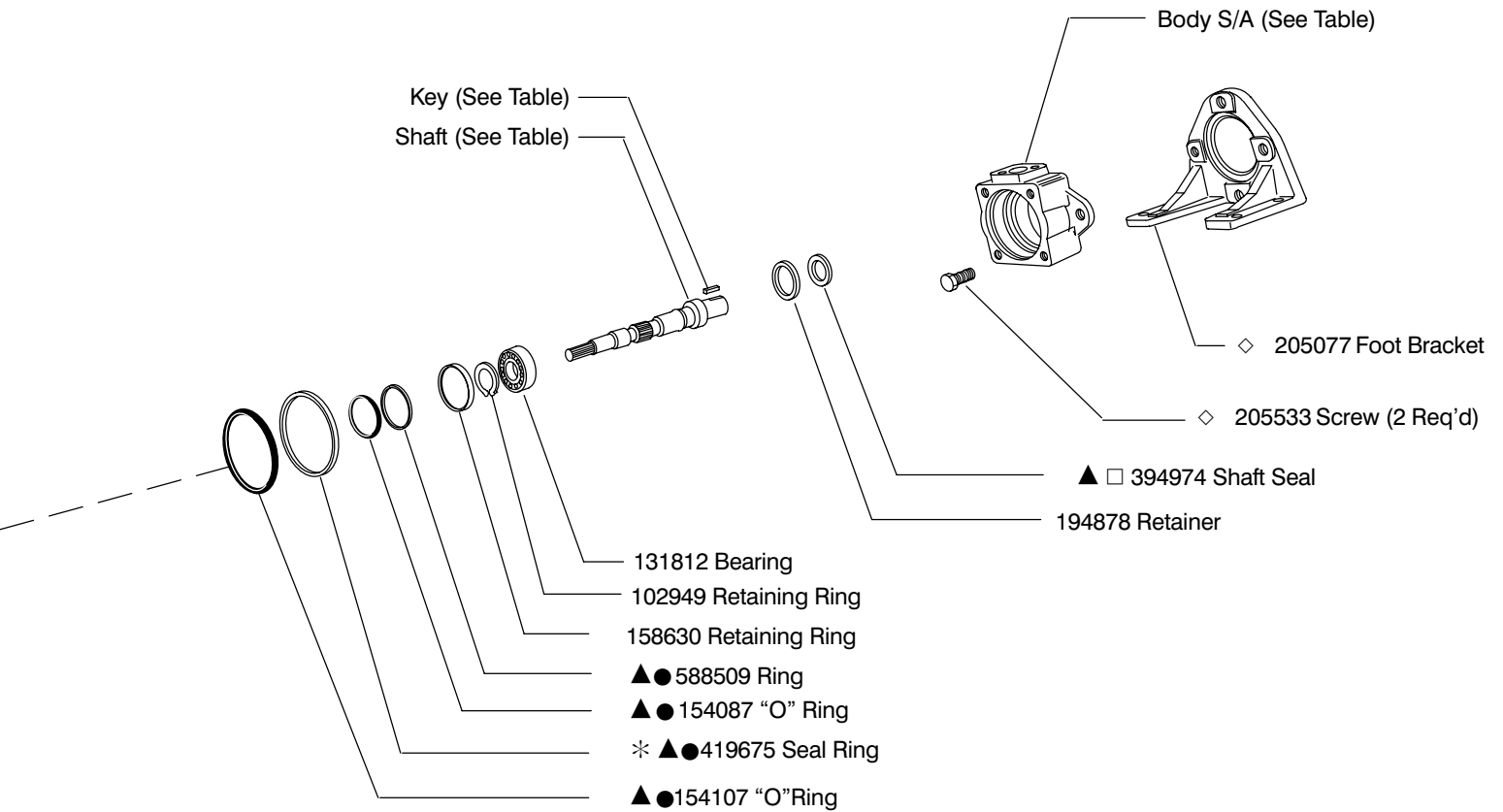

MODEL	COVER	HOUSING	BODY S/A
4520V**A	250824	252283	942356
4520V**E	252504		942356
4520VM**A	478510	478507	02-136925
4520VM**AM			02-136926

SHAFT	TYPE	KEY
255533	(1) keyed	217596
255536	(11) splined	—
361761	(86) keyed	239751
850613	(192N) keyed	472303

NOTE:

For satisfactory service life of these components in industrial applications, use full flow filtration to provide fluid which meets ISO cleanliness code 16/13 or cleaner. OFP, OFR, and OFRS series filters are recommended.

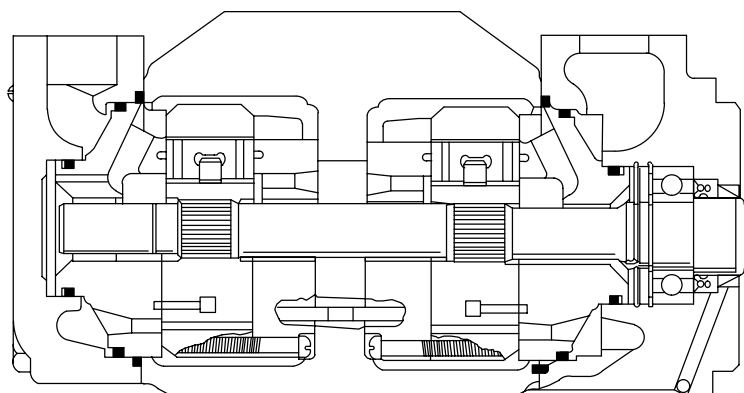

Model Code

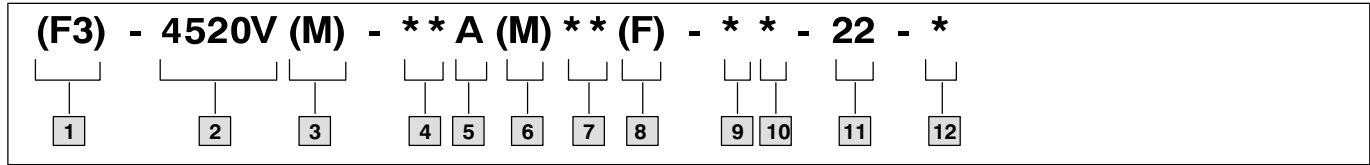

1 Special seals

2 Series designation

Displacements cm^3/r (in^3/r)

Model	Shaft end	Cover end
4520V	138 – 193 (8.41–11.75)	18 – 45 (1.1 – 2.22)

3 Pilot designation

M – Metric per ISO 3019/2 100A2HW
Omit – Standard pilot

4 Geometric displacement

Shaft end pump

(Rated capacity (USgpm) at 1200 rpm, 6.9 bar (100 psi))

Frame size	Code	cm^3/r	in^3/r
4520V	42	138	8.41
	45	147	9.00
	50	162	9.85
	60	193	11.75

5 Port connections

A – SAE 4 bolt flange

6 Port connection modifier

M – Metric port connection (4 bolt flange)

Omit – Inch thread port connection (4 bolt flange)

7 Geometric displacement

Cover end pump

(Rated capacity (USgpm) at 1200 rpm, 6.9 bar (100 psi))

Frame size	Code	cm^3/r	in^3/r
4520V	2	6.5	0.40
	5	18	1.10
	8	27	1.67
	11	36	2.22
	12	40	2.47
	14	45	2.78

8 Mounting

F – Foot mounting

Omit – Flange mounting

9 Shaft

1 – Straight keyed

11 – Splined

86 – Heavy duty straight keyed

192N – Straight keyed (M pilot only)

10 Port orientation

(Viewed from cover end of pump)

With no. 1 outlet opposite inlet

AA – No. 2 outlet 135° CCW from inlet

AB – No. 2 outlet 45° CCW from inlet

AC – No. 2 outlet 45° CW from inlet

AD – No. 2 outlet 135° CW from inlet

With no. 1 outlet 90° CCW from inlet

BA – No. 2 outlet 135° CCW from inlet

BB – No. 2 outlet 45° CCW from inlet

BC – No. 2 outlet 45° CW from inlet

BD – No. 2 outlet 135° CW from inlet

With no. 1 outlet inline with inlet

CA – No. 2 outlet 135° CCW from inlet

CB – No. 2 outlet 45° CCW from inlet

CC – No. 2 outlet 45° CW from inlet

CD – No. 2 outlet 135° CW from inlet

With no. 1 outlet 90° CW from inlet

DA – No. 2 outlet 135° CCW from inlet

DB – No. 2 outlet 45° CCW from inlet

DC – No. 2 outlet 45° CW from inlet

DD – No. 2 outlet 135° CW from inlet

11 Design

12 Rotation

(Viewed from shaft end of pump)

L – Left hand for counterclockwise

R – Right hand for clockwise

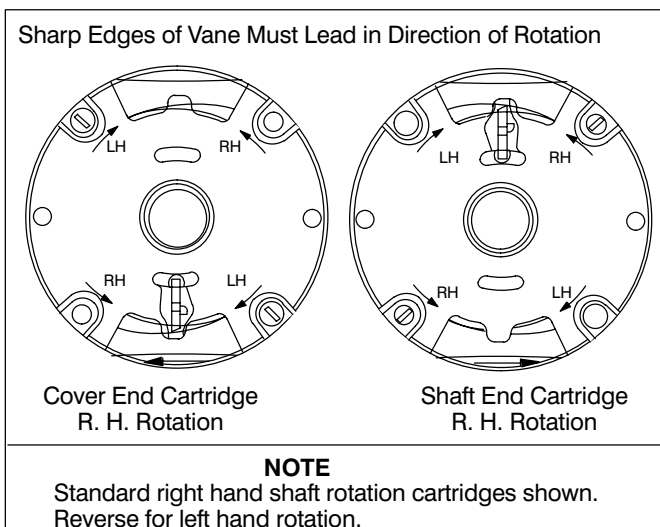

NOTE

To reverse cartridge kit rotation, remove the two screws and reverse the location of the inlet support plate and the outlet support plate. Reinstall the two screws hand tight. Use pump cover to align all sections of the cartridge. Carefully remove the cover and tighten the screws.

When ordering spare cartridge parts, it is recommended they be obtained in cartridge kits. Kits are assembled and tested for either right or left hand rotation. If left hand rotation is required, it should be specified on parts order by adding suffix "L" to cartridge kit number.