

Service Data

Vickers®

Vane Pumps



Vane Type Double Pump

(F3)–3525V(M)–**A(M)**(F)–**–22–*

MODEL	■ ROTOR	■ VANE KIT	■ RING	■ INLET PLATE	Cover End ■ CART. KIT	Cover End ■ F3 CART. KIT
3525V***12	584618	02-136719	584610	588689	02-102536	02-102544
3525V***14			584612		02-102537	02-102545
3525V***17			584614		02-102538	02-102546
3525V***21			584616		02-102539	02-102547

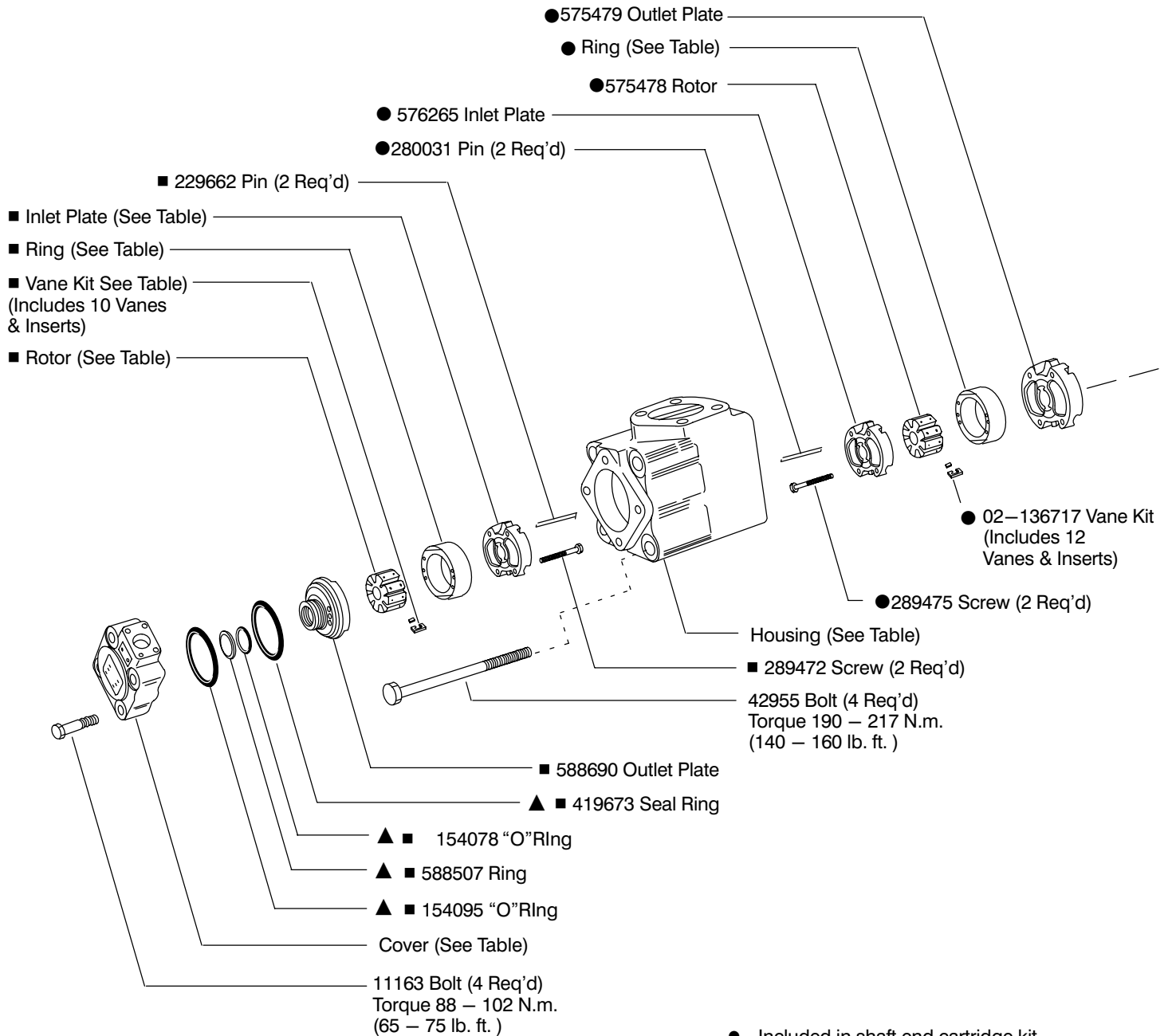

- Included in shaft end cartridge kit
- Included in cover end cartridge kit
- ▲ Included in seal kit 922862
F3 equivalent seal kit 919305
- ◇ Included in foot bracket kit FB-C-10
- Assemble seal with spring loaded sealing member towards bearing. Seals to be completely wetted with oil prior to assembly.
- * Install 419674 sealing ring into body, then install cartridge kit.

MODEL	● RING	Shaft End ● CART KIT	Shaft End ● F3 CART KIT
3525V25	576210	02-102552	02-102560
3525V30	576212	02-102553	02-102561
3525V35	576214	02-102554	02-102562
3525V38	575476	02-102555	02-102563

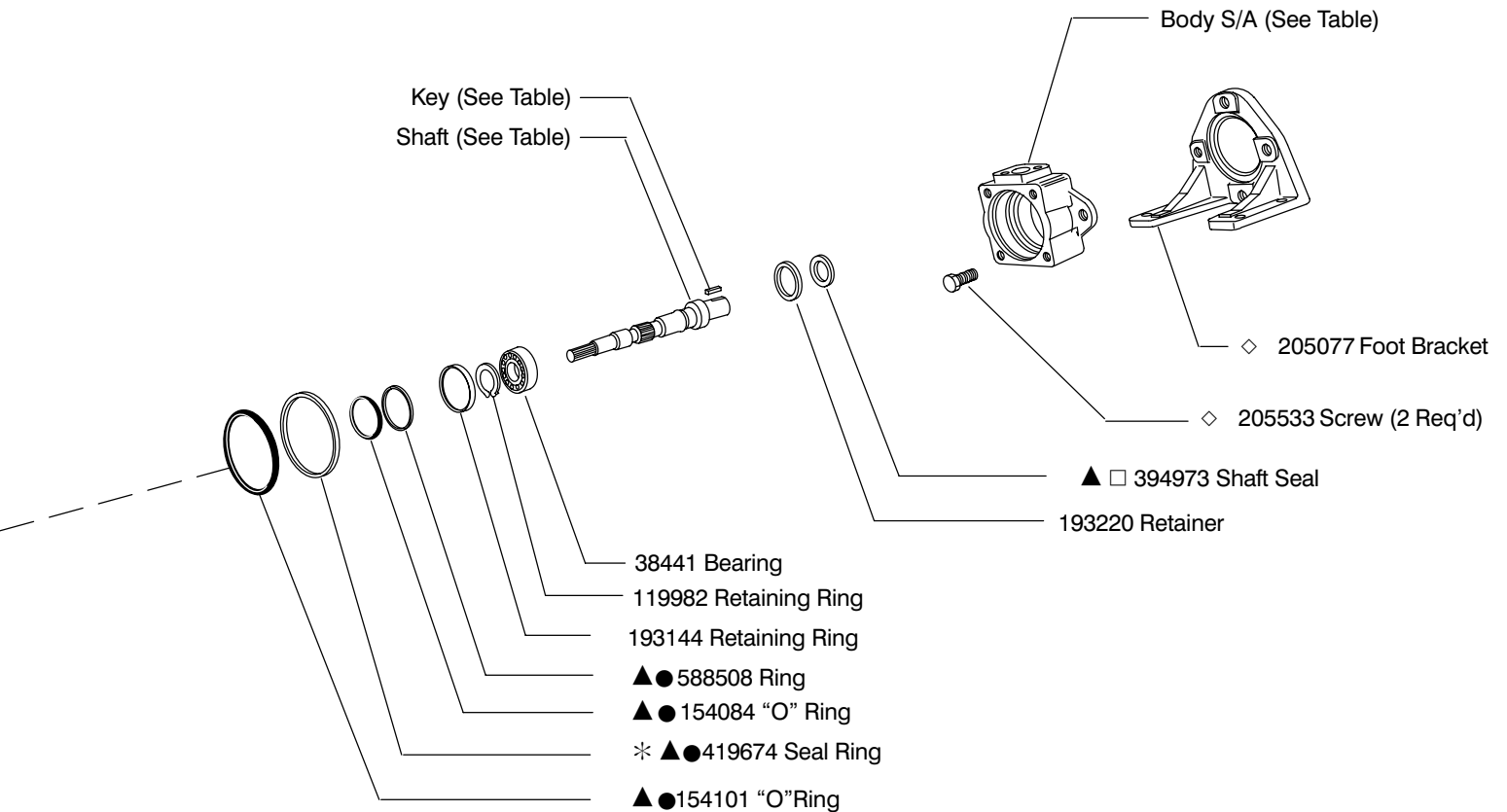

MODEL	COVER	HOUSING	BODY S/A
3525V**A	231532	230189	942355
3525V**E	242250		942355
3525VM**A	231532	995239	02-136921
3525VM**AM	478512		02-136922

SHAFT	TYPE	KEY
243448	(1) keyed	88678
243449	(11) splined	—
394036	(86) keyed	393536
860098	(192N) keyed	472287

NOTE

For satisfactory service life of these components in industrial applications, use full flow filtration to provide fluid which meets ISO cleanliness code 16/13 or cleaner. OFP, OFR, and OFRS series filters are recommended.

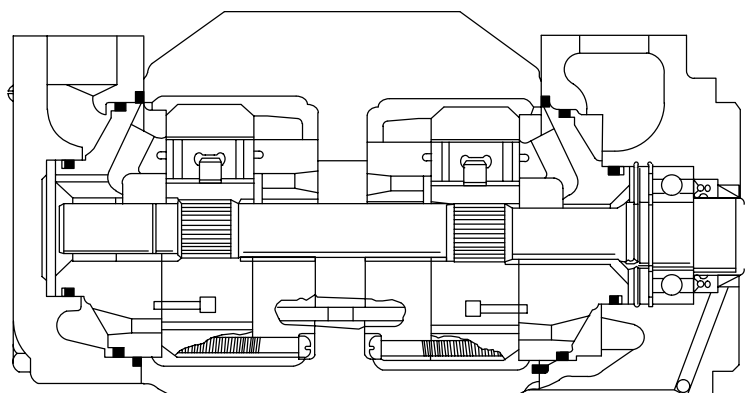

Model Code

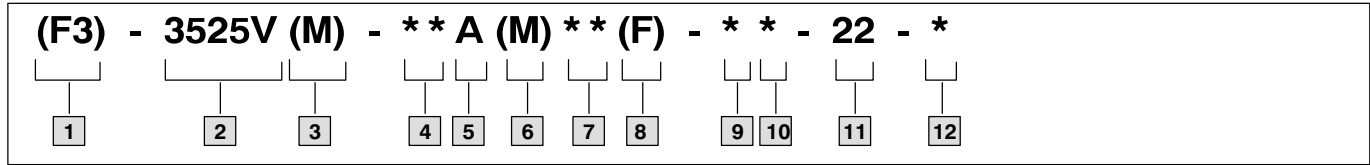

1 Special seals

2 Series designation

Displacements cm^3/r (in^3/r)

Model	Shaft end	Cover end
3525V	81 – 121 (4.94–7.37)	40 – 67 (2.47 – 4.13)

3 Pilot designation

M – Metric per ISO 3019/2 100A2HW
Omit – Standard pilot

4 Geometric displacement

Shaft end pump

(Rated capacity (USgpm) at 1200 rpm, 6.9 bar (100 psi))

Frame size	Code	cm^3/r	in^3/r
3525V	25	81	4.94
	30	97	5.91
	35	112	6.83
	38	121	7.37

5 Port connections

A – SAE 4 bolt flange

6 Port connection modifier

M – Metric port connection (4 bolt flange)
Omit – Inch thread port connection (4 bolt flange)

7 Geometric displacement

Cover end pump

(Rated capacity (USgpm) at 1200 rpm, 6.9 bar (100 psi))

Frame size	Code	cm^3/r	in^3/r
3525V	12	40	2.47
	14	45	2.78
	17	55	3.39
	21	67	4.13

8 Mounting

F – Foot mounting
Omit – Flange mounting

9 Shaft

1 – Straight keyed
11 – Splined
86 – Heavy duty straight keyed
192N – Straight keyed (M pilot only)

10 Port orientation

(Viewed from cover end of pump)

With no. 1 outlet opposite inlet

AA – No. 2 outlet 135° CCW from inlet
AB – No. 2 outlet 45° CCW from inlet
AC – No. 2 outlet 45° CW from inlet
AD – No. 2 outlet 135° CW from inlet

With no. 1 outlet 90° CCW from inlet

BA – No. 2 outlet 135° CCW from inlet
BB – No. 2 outlet 45° CCW from inlet
BC – No. 2 outlet 45° CW from inlet
BD – No. 2 outlet 135° CW from inlet

With no. 1 outlet inline with inlet

CA – No. 2 outlet 135° CCW from inlet
CB – No. 2 outlet 45° CCW from inlet
CC – No. 2 outlet 45° CW from inlet
CD – No. 2 outlet 135° CW from inlet

With no. 1 outlet 90° CW from inlet

DA – No. 2 outlet 135° CCW from inlet
DB – No. 2 outlet 45° CCW from inlet
DC – No. 2 outlet 45° CW from inlet
DD – No. 2 outlet 135° CW from inlet

11 Design

12 Rotation

(Viewed from shaft end of pump)

L – Left hand for counterclockwise
R – Right hand for clockwise

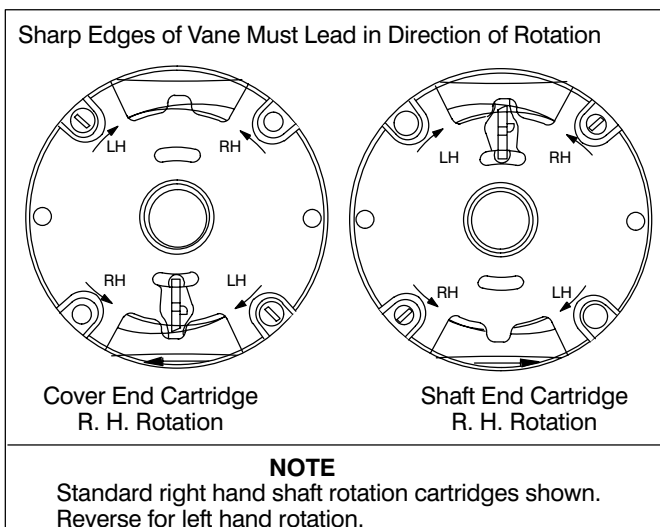

NOTE

To reverse cartridge kit rotation, remove the two screws and reverse the location of the inlet support plate and the outlet support plate. Reinstall the two screws hand tight. Use pump cover to align all sections of the cartridge. Carefully remove the cover and tighten the screws.

When ordering spare cartridge parts, it is recommended they be obtained in cartridge kits. Kits are assembled and tested for either right or left hand rotation. If left hand rotation is required, it should be specified on parts order by adding suffix "L" to cartridge kit number.