

Eaton®
Medium Duty Piston Pump

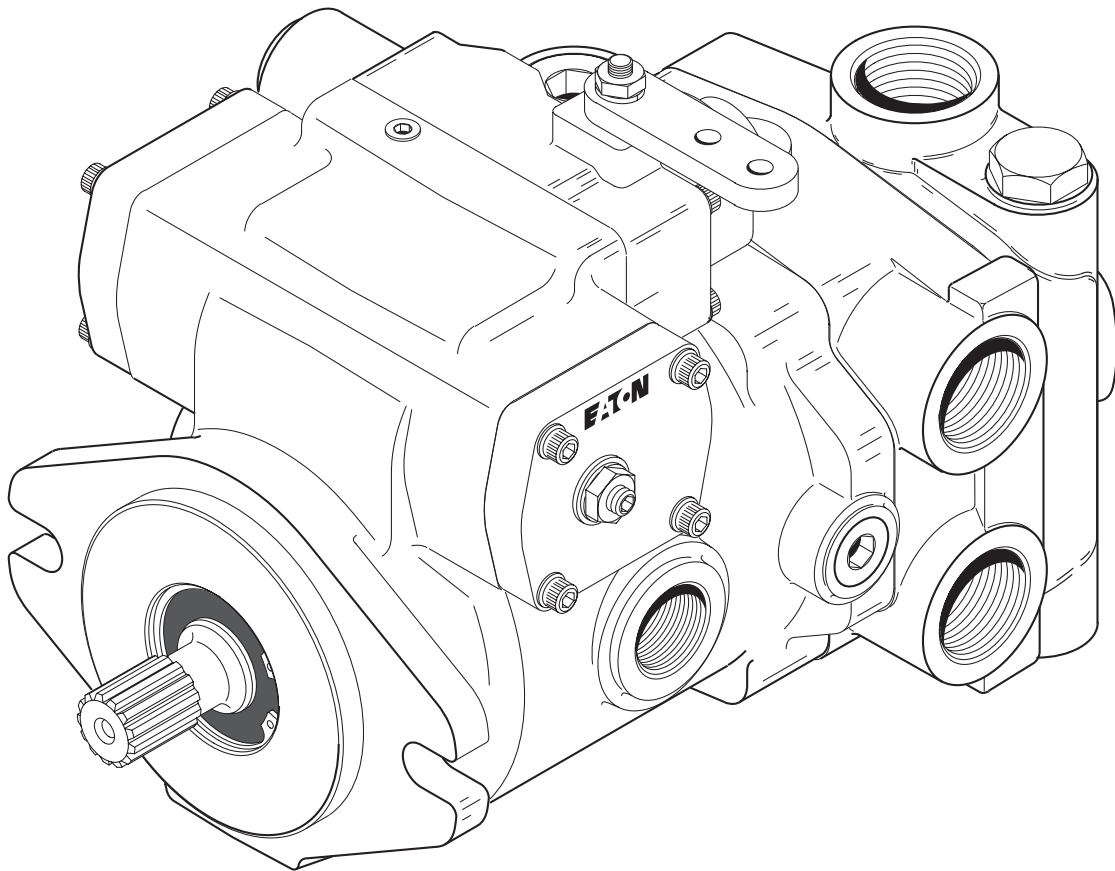

Parts Information



Model 72400
Servo Controlled Piston Pump

Parts Drawing

Pump drawn below is typical of a righthand rotation with porting out the left side of pump.

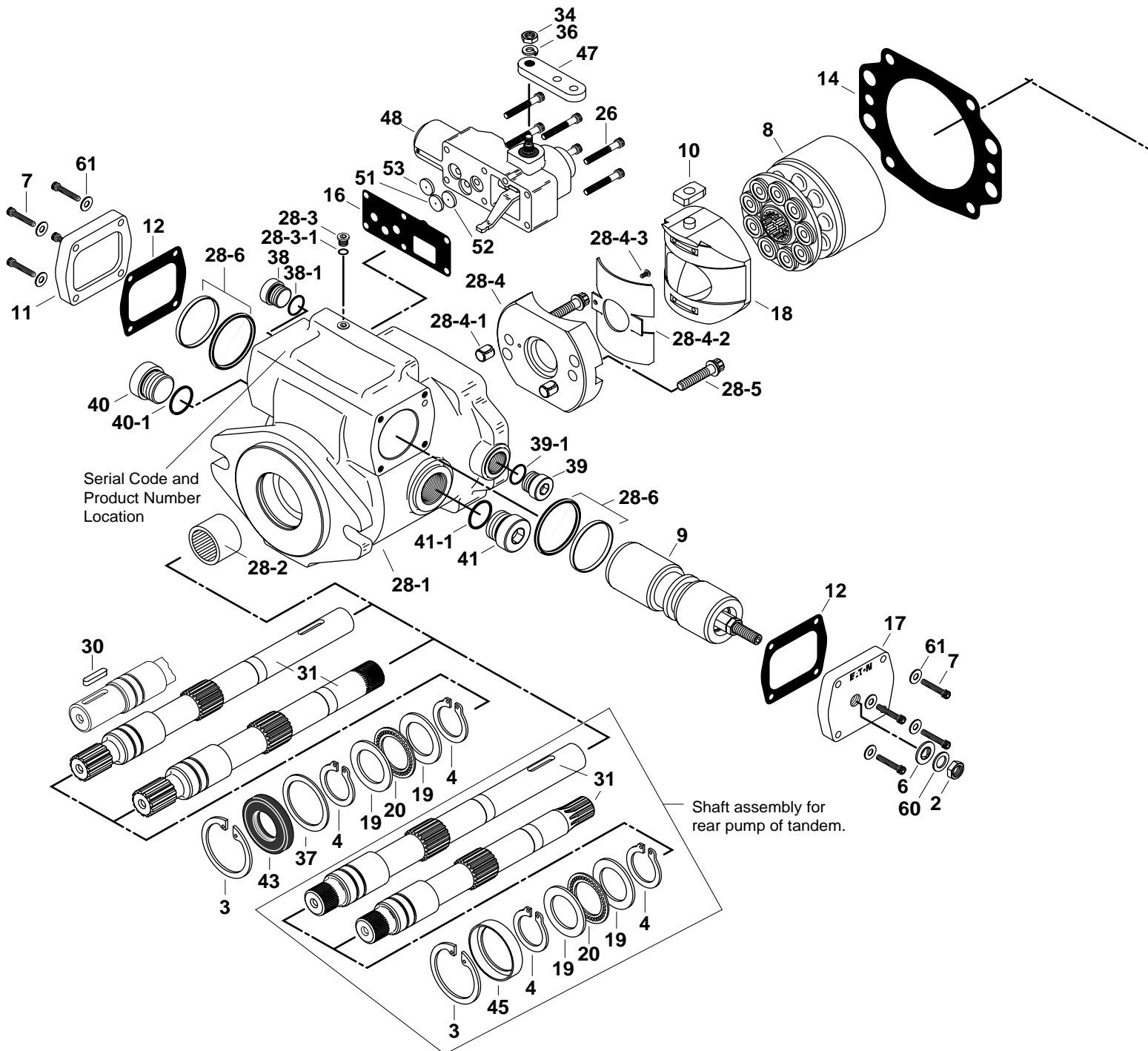

Parts Drawing

Assembly for Front pump of Tandem

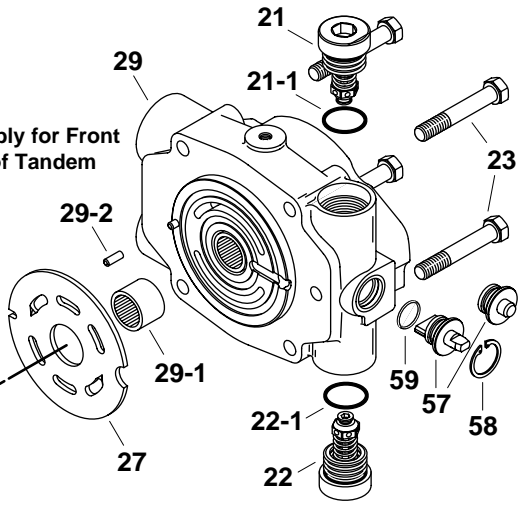

Assembly for single pump or rear pump of tandem.

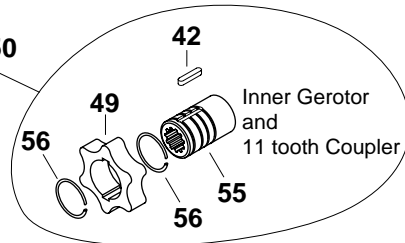
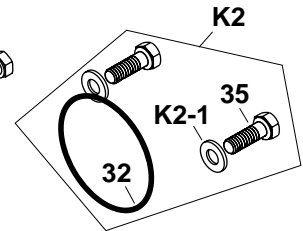
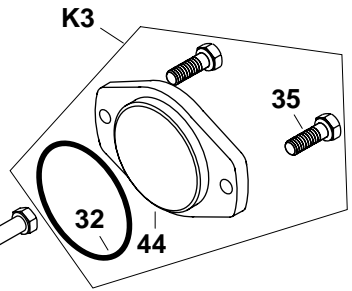
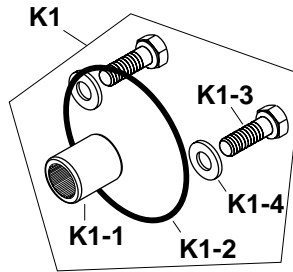
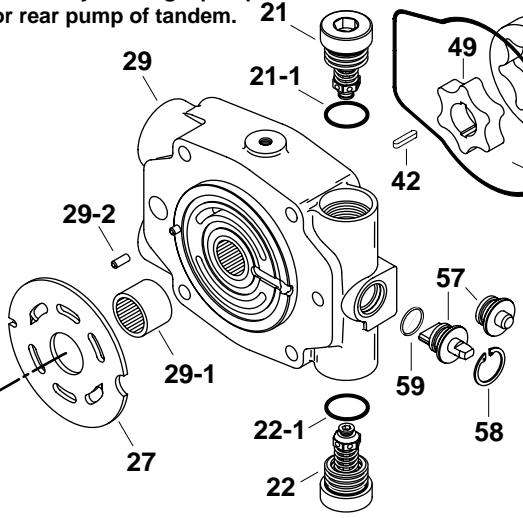

Valve Plate Identification

Note "V" notch locations

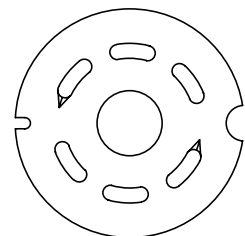
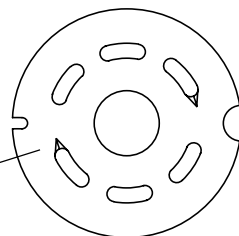

Lefthand Rotation

Righthand Rotation

Parts List

Item	Part No.	Qty.	Description	
	2	1	Jam Nut	
+	3	1	Retaining Ring	
+	4	2	Retaining Ring	
+	6	1	Seal Washer	
	7	8	Cap Screw, #10-24, 25.4 mm [1.0 in.] Long	
	8	1	Rotating Kit Assembly, 2.48 in ³ /r (parts list on page 6)	
	9	1	Servo Piston Assembly (parts list on page 6)	
	10	1	Servo Piston Follower	
	11	1	Cover Plate	
+	12	2	Cover Plate Gasket	
+	14	1	Housing Gasket	
+	16	1	Control Housing Gasket	
	17	1	Cover Plate	
	18	1	Camplate	
	19	2	Thrust Race	
	20	1	Thrust Bearing	
	21	1	Relief Valve for Port "C" (parts list on page 7)	
+	21-1	1	O-ring, 2.95 mm Dia. x 23.47 mm I.D. [.116 in. Dia. x .924 in. I.D.]	
	22	1	Relief Valve for Port "D" (parts list on page 7)	
+	22-1	1	O-ring, 2.95 mm Dia. x 23.47 mm I.D. [.116 in. Dia. x .924 in. I.D.]	
	23	4	Cap Screw, 3/8-16, 57.2 mm [2.25 in.] Long	
	24	2	Cap Screw, 3/8-16, 88.9 mm [3.5 in.] Long	
	25	2	Cap Screw, 3/8-16, 101.6 mm [4.0 in.] Long	
	26	6	Cap Screw	
	27	1	Valve Plate, 2.48 in ³ /r	
	70344-51		Righthand (CW) Rotation	
	70344-52		Lefthand (CCW) Rotation	
	28	1	Housing Assembly (Identification on page 7)	
	28-1	1	Housing (Identification on page 7)	
	28-2	1	Bearing (press fit)	
	28-3	1	Plug Sub-Assembly	
+	28-3-1	1	O-ring, 1.63 mm Dia. x 6.1 mm I.D. [.064 in. Dia. x .239 in. I.D.]	
	28-4	1	Cradle Sub-Assembly	
	28-4-1	2	Dowel Bushing	
	28-4-2	1	Bushing	
	28-4-3	1	Cap Screw, Button Head	
	28-5	2	Cap Screw	
+	28-6	2	Seal Sub-Assembly	
	29	1	Backplate Assembly (Identification on page 8 & 9)	
	29-1	1	Bearing (press fit)	
	29-2	1	Roll Pin	
	30	1	Key	
	31	1	Drive Shaft (Identification on page 15)	
	72400-200		15 tooth, 16/32 DP - w/ 41 tooth, 48/96 DP (Tandem Front Pump)	
	72400-201		41 tooth, 48/96 DP - w/ 11 tooth, 16/32 DP (Tandem Rear Pump)	
	72400-202		41 tooth, 48/96 DP - w/ 9 tooth, 16/32 DP (Tandem Rear Pump)	
	72400-204		15 tooth, 16/32 DP - w/ 9 tooth, 16/32 DP (Single Pump)	
	72400-211		13 tooth, 16/32 DP - w/ 9 tooth, 16/32 DP (Single Pump)	
	72400-212		15 tooth, 16/32 DP - w/ 11 tooth, 16/32 DP (Single Pump)	
	72400-213		25.4 [1.00] Dia. Str., w/ keyway - w/ 9 tooth, 16/32 DP (Single Pump)	
+	32	1	O-ring, 1.59 mm Dia. x 82.55 mm I.D. [.0625 in. Dia. x 3.25 in. I.D.]	
+	33	1	Molded O-ring	
	34	1	Nut	
	35	2	Cap Screw, 3/8-16, 25.4 mm [1.0 in.] Long	
	36	1	Lockwasher	
	37	1	Washer	
	38	1	Plug	
4	+	38-1	1	O-ring, 2.21 mm Dia. x 16.36 mm I.D. [.087 in. Dia. x .644 in. I.D.]

Parts List

Item	Part No.	Qty.	Description
	39	1	Plug
+	39-1	1	O-ring, 2.21 mm Dia. x 16.36 mm I.D. [.087 in. Dia. x .644 in. I.D.]
	40	1	Plug
+	40-1	1	O-ring, 2.95 mm Dia. x 23.47 mm I.D. [.116 in. Dia. x .924 in. I.D.]
	41	1	Plug
+	41-1	1	O-ring, 2.95 mm Dia. x 23.47 mm I.D. [.116 in. Dia. x .924 in. I.D.]
	42	1	Key Used with 9 tooth internal spline through shafts
	16246-429		Used on 11 tooth drive coupler with 12.7 mm [.5 in.] width gerotor
	16246-431		Used on 11 tooth drive coupler with 6.35 mm [.25 in.] width gerotor
	16244-443		Used on 11 tooth drive coupler with 6.35 mm [.25 in.] width gerotor
+	43	1	Shaft Seal
	44	1	Cover Plate
	45	1	Spacer
	46	1	Charge Pump Adapter Assembly (parts list & ID. on Page 10 & 11)
	47	1	Control Arm
	48	1	Servo Control Assembly (parts list & ID. on Page 12 & 13)
	49	1	Inner Ring Gerotor (match displacement with Item 46 & 50)
	79004-611		6.9 mL/r [.42 cu. in./r] displacement, 6.35 mm [.25 in.] width
	79004-605		13.8 mL/r [.84 cu. in./r] displacement, 12.7 mm [.5 in.] width
	72400-640		13.8 mL/r [.84 cu. in./r] displacement (used with Item 55 coupler)
50		1	Outer Ring Gerotor (match displacement with Item 46 & 49)
	79004-612		6.9 mL/r [.42 cu. in./r] displacement, 6.35 mm [.25 in.] width
	79004-606		13.8 mL/r [.84 cu. in./r] displacement, 12.7 mm [.5 in.] width
51	◆	1	Supply Orifice (orifice chart on page 14)
52	◆	1	Control Valve Orifice (orifice chart on page 14)
53	◆	1	Control Valve Orifice (orifice chart on page 14)
55	72400-639	1	Coupler, 11 tooth
56	72400-638	2	Retaining Ring, (used with Item 55)
57		1	Dump Valve
	72400-515		Dump Valve Actuator
	72400-518		Plug (selected when dump valve is not required)
+	58	1	Retaining Ring
+	59	1	Quad-ring, 1.59 mm Dia. x 15.9 mm I.D. [.0625 in. Dia. x .625 in. I.D.]
	60	1	Washer
	61	8	Washer
	62	4	Washer

Kits

K1	72400-902	1	Tandem Servo Piston Pump Mounting Kit
K1-1	70411-622	1	Coupler, 41 tooth
+	K1-2	1	O-ring, 1.59 mm Dia. x 101.6 mm I.D. [.0625 in. Dia. x 4 in. I.D.]
	K1-3	2	Cap Screw, 3/8-16, 25.4 mm [1.0 in.] Long
	K1-4	2	Washer
K2	70442-929	1	Gear Pump Mounting Kit Includes Items 32 and 35
K2-1	16048-113	2	Washer
K3	70142-915	1	Cover Plate Kit for "A" SAE Flange Series 82-2 Mount Includes Items 32, 35, and 44
	72400-908	1	Seal Repair Kit for single pumps (Two Required for Tandem Units)
	72400-900	1	Dump valve kit, Includes Items 57 (Actuator), 58, & 59
	72400-901	1	Dump valve plug kit, Includes Items 57 (Plug), 58, & 59

Legend

- ◆ Refer to specific Item parts list.
- +

Parts included in 72400-908 Seal Repair kit.

Item 8 - Rotating Kit Assembly

Item 9 - Servo Piston Assembly

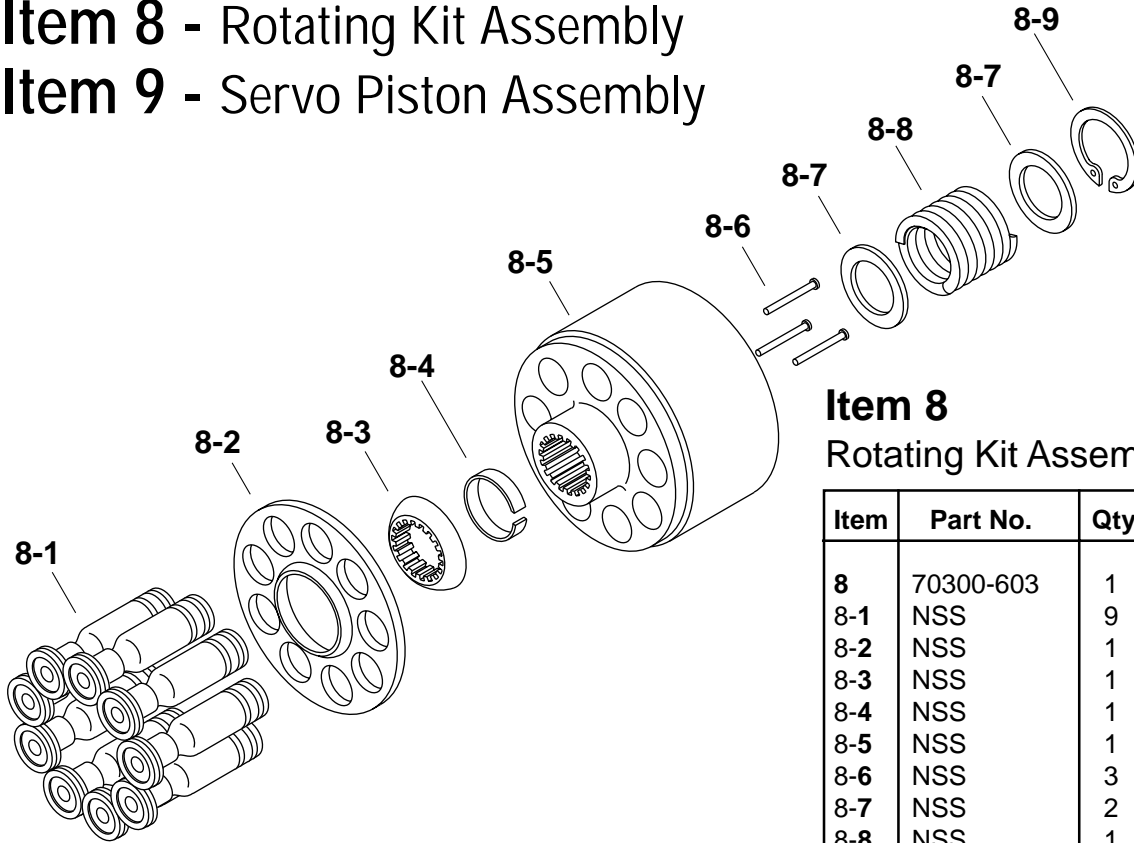

Item 8 Rotating Kit Assembly

Item	Part No.	Qty.	Description
8	70300-603	1	Rotating Kit Assy.
8-1	NSS	9	Piston Assembly
8-2	NSS	1	Spider
8-3	NSS	1	Spider Pivot
8-4	NSS	1	Retainer
8-5	NSS	1	Piston Block
8-6	NSS	3	Pins
8-7	NSS	2	Washer
8-8	NSS	1	Spring
8-9	NSS	1	Retaining Ring

NSS - Not Sold Separately

Note: Do not disassemble servo piston assembly.

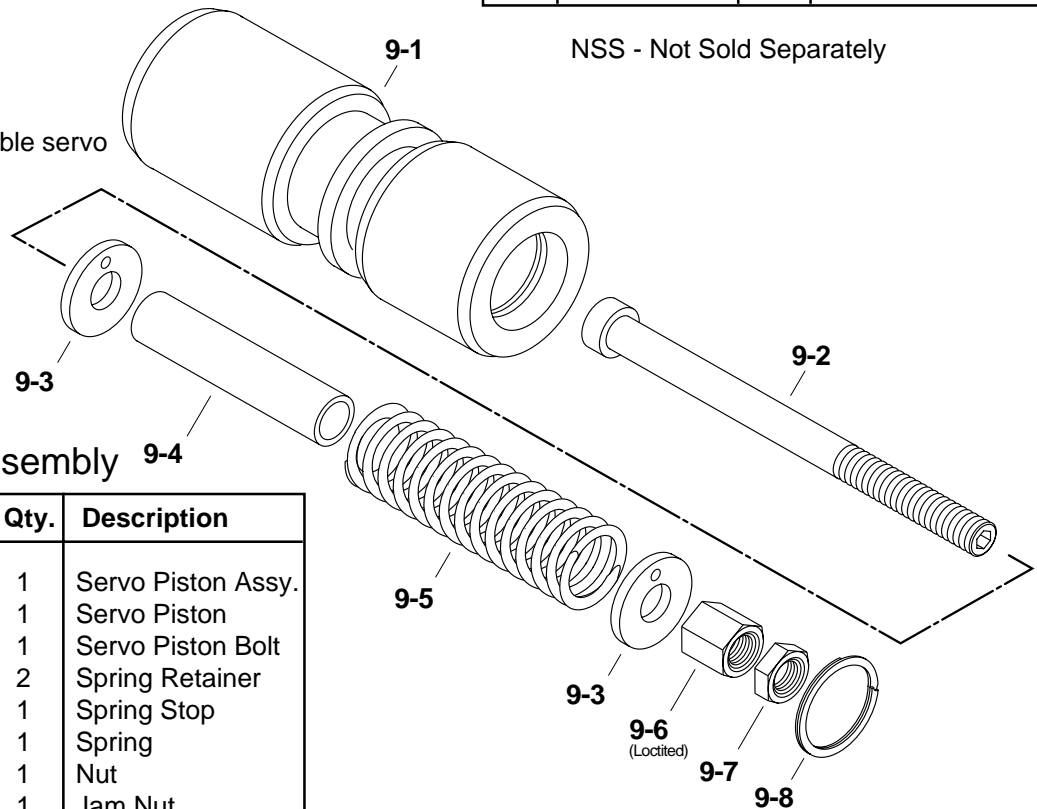

Item 9 Servo Piston Assembly

Item	Part No.	Qty.	Description
9	72400-576	1	Servo Piston Assy.
9-1	NSS	1	Servo Piston
9-2	NSS	1	Servo Piston Bolt
9-3	NSS	2	Spring Retainer
9-4	NSS	1	Spring Stop
9-5	NSS	1	Spring
9-6	NSS	1	Nut
9-7	NSS	1	Jam Nut
9-8	NSS	1	Retaining Ring

NSS - Not Sold Separately

Item 21 or 22 - Relief Valve

Item 28 - Housing Identification

Item 21 or 22

Internal Relief Valve Settings Available

Part Number	bar [PSI]
106639-200	138 [2000]
106639-250	172 [2500]
106639-300	207 [3000]
106639-350	241 [3500]
106639-400	276 [4000]
106639-450	310 [4500]
106639-500	345 [5000]

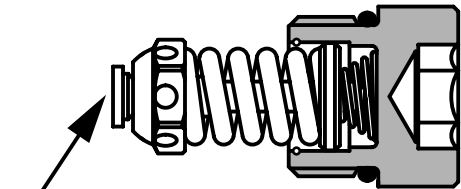

Dash Number Stamped here for Valve Pressure Setting Identification
 Example: 500 x 10 = [5000 PSI] 345 bar

Item 28

Housing Identification

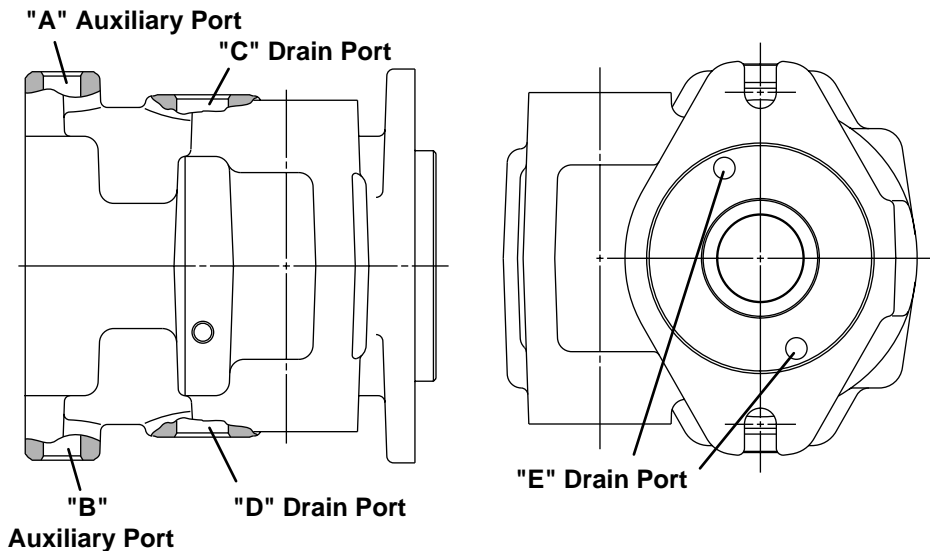

Housing Assy. Item	Part No.	Housing Item	Part No.	Qty.	Port Machined
28	72339-001	28-1	72338-001	1	A, B, C, D
28	72339-012	28-1	72338-012	1	A, B, C, D, E
28	72339-013	28-1	72338-013	1	A, B, E

Item 29 - Backplate Assembly Identification

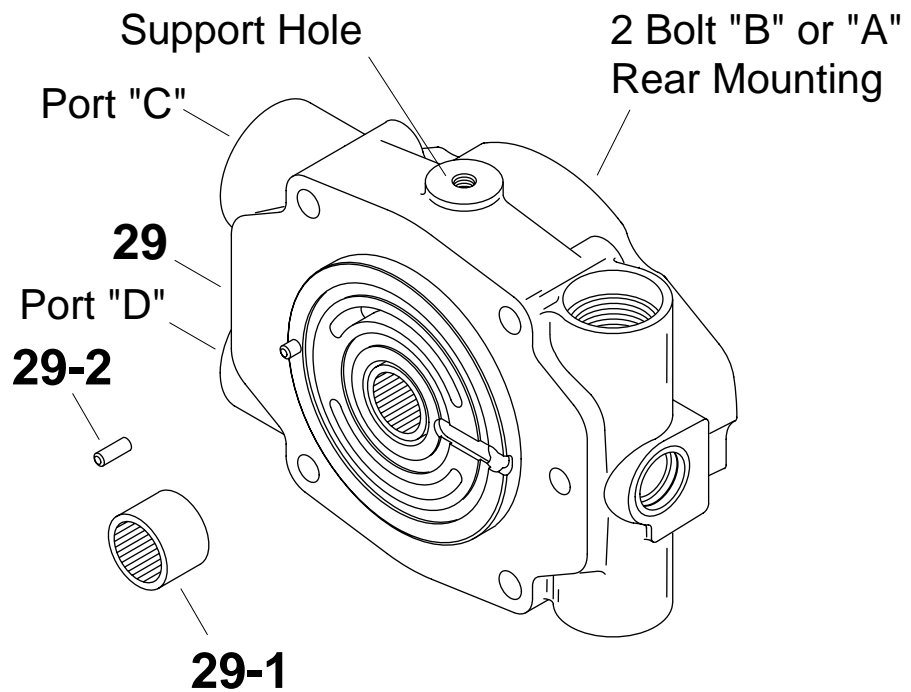
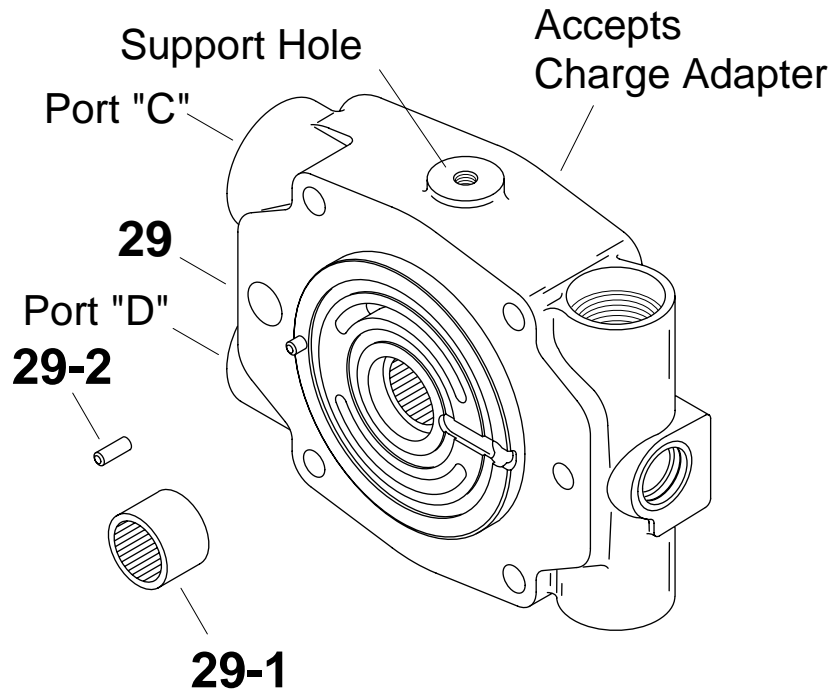

Item 29 - Parts List

Parts List

Item	Part No.	Qty.	Description
29	Chart Below	1	Backplate Assembly
29-1	52200-23	1	Bearing (press fit)
29-2	16026-610	1	Roll Pin

Item 29 - Backplate Assembly Part Number Identification

Rear Mounting	Support Hole	Item 29 Backplate Assembly Part Number
Rear "B" Mount (no gerotor charge adapter)	with Hole	72346-005
	None	72346-001
Accepts Gerotor Charge Pump Adapter with "A" Mount	with Hole	72342-005
	None	72342-001
Rear "A" Mount (no gerotor charge adapter)	with Hole	72344-005
	None	72344-001

Item 46 - Charge Pump Adapter Assembly

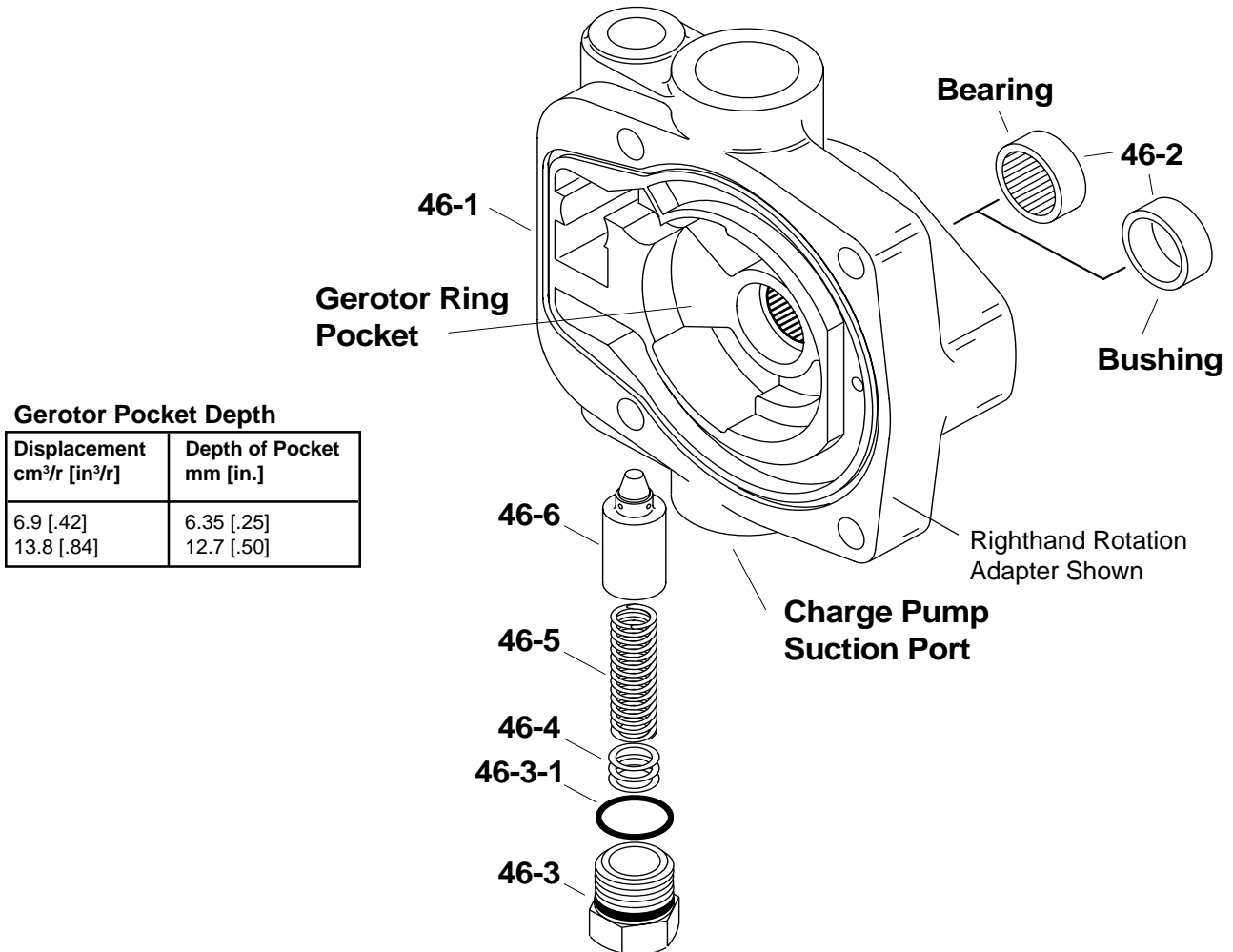

Gerotor Pocket Depth

Displacement cm ³ /r [in ³ /r]	Depth of Pocket mm [in.]
6.9 [.42]	6.35 [.25]
13.8 [.84]	12.7 [.50]

Item	Part No.	Qty.	Description
46	See Chart	1	Assembly, Charge Pump Adapter
46-1	NSS	1	Charge Pump Adapter
46-2	16239-1148	1	Bearing (press fit), Used w/9 tooth output shaft
46-2	72400-637	1	Bushing (press fit), Used w/11 tooth output shaft
46-3	72400-659	1	Plug
+ 46-3-1	16133-10	1	O-ring
46-4	16048-597	<i>f</i>	Shims
46-5	17059-16	1	Spring
46-6	72400-679	1	Poppet

f - Shim as required
 NSS - Not sold separately

Item 46 - Charge Pump Adapter Identification

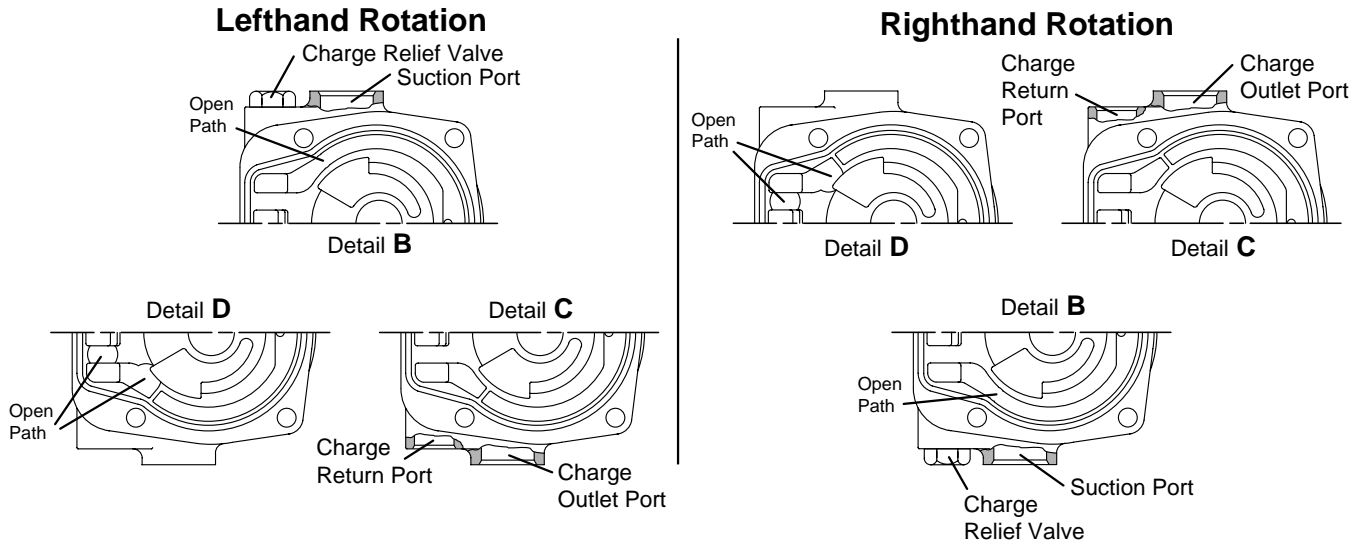

Adapter, Item 46, Identification Chart

Charge Pump Routing	Shaft Rotation	Refer to Detail	9 Tooth Output Shaft		11 Tooth Output Shaft	
			6.9 cm ³ /r [.42 in ³ /r] Displacement	13.8 cm ³ /r [.84 in ³ /r] Displacement	6.9 cm ³ /r [.42 in ³ /r] Displacement	13.8 cm ³ /r [.84 in ³ /r] Displacement
Charge Relieved to Case	Righthand	B & D	72356-010	72356-011	72348-010	72348-011
	Lefthand	B & D	72358-010	72358-011	72360-010	72360-011
Remote Filter and Charge Relieved to Case	Righthand	B & C	72356-007	72356-008	72348-007	72348-008
	Lefthand	B & C	72358-007	72358-008	72360-007	72360-008

Item 48 - Manual Servo Control Assembly

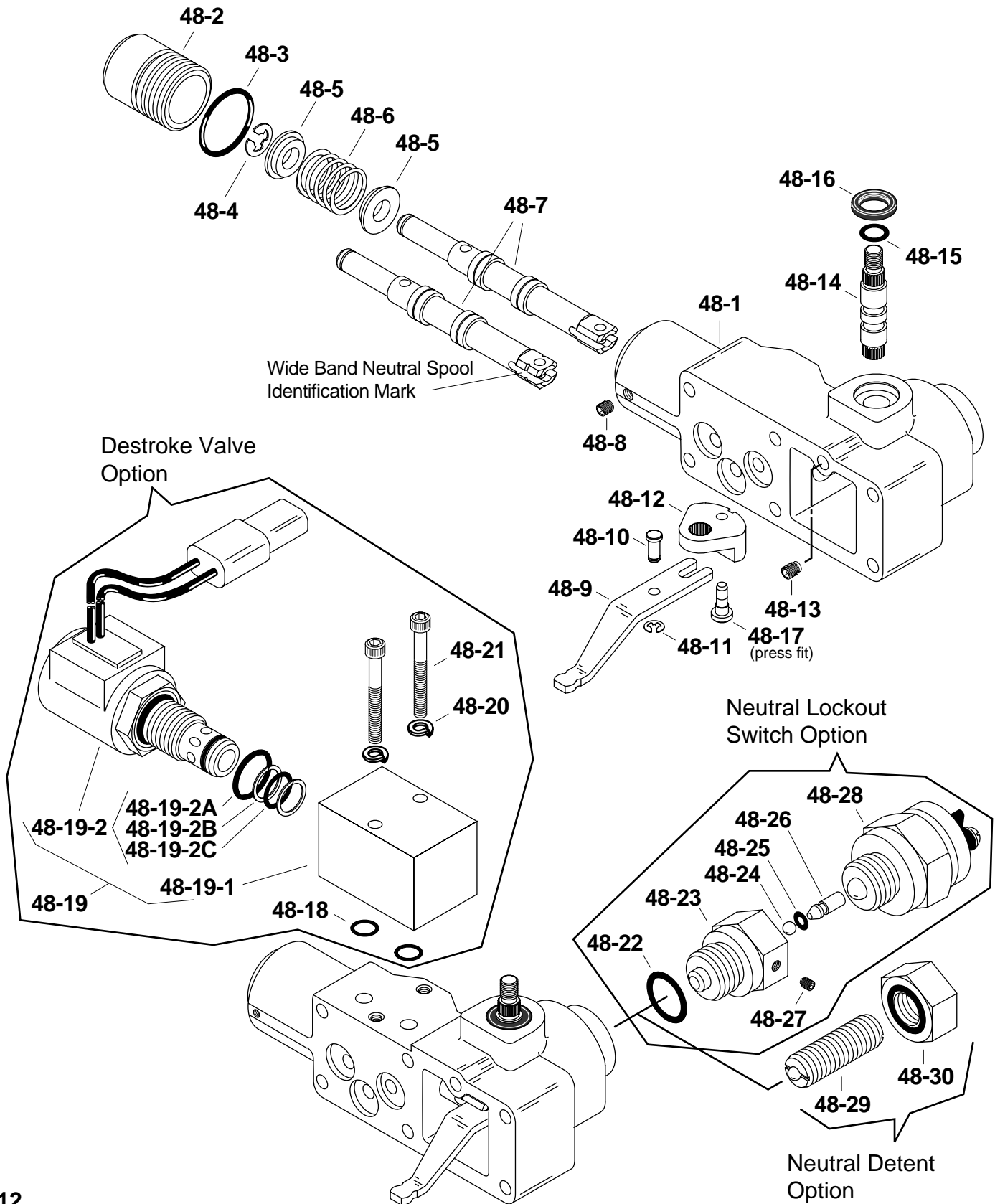

Item 48 - Parts List

Item	Part No.	Qty	Description	-AA	-AB	-AC	-AD	-AE	-AF	-AG	-AH
48	72401-AA		Assembly with no additional features								
48	72401-AB		Assembly with Neutral Lockout, Destroke valve & Wide Band Neutral								
48	72401-AC		Assembly with Neutral Lockout & Wide Band Neutral								
48	72401-AD		Assembly with Destroke Valve								
48	72401-AE		Assembly with Neutral Detent & Wide Band Neutral								
48	72401-AF		Assembly with Neutral Detent, Destroke valve & Wide Band Neutral								
48	72401-AG		Assembly with W/B Neutral Spool								
48	72401-AH		Assembly with W/B Neutral Spool & Destroke Valve								
48		1	Manual Servo Control Assembly								
48-1		1	Control Housing								
	72319-001		Control Housing	X						X	
	72319-002		Control Housing			X					
	72319-003		Control Housing				X				X
	72319-004		Control Housing		X						
	72319-005		Control Housing					X			
	72319-006		Control Housing						X		
48-2	72400-507	1	Plug	X	X	X	X	X	X	X	X
+ 48-3	16015-8	1	O-ring	X	X	X	X	X	X	X	X
48-4	16124-31	1	Retaining Ring	X	X	X	X	X	X	X	X
48-5	72400-504	2	Spring Retainer	X	X	X	X	X	X	X	X
48-6	17073-14	1	Spool Centering Spring	X	X	X	X	X	X	X	X
48-7		1	Valve Spool								
	72400-501		Standard	X			X				
	72400-544		Wide Band Neutral		X	X		X	X	X	X
48-8	102149-019	1	Set Screw	X	X	X	X	X	X	X	X
48-9	72400-502	1	Feedback Link	X	X	X	X	X	X	X	X
48-10	72400-508	1	Dowel Pin	X	X	X	X	X	X	X	X
48-11	16124-15	1	Retaining Ring	X	X	X	X	X	X	X	X
48-12	72400-519	1	Bell Crank	X	X	X	X	X	X	X	X
48-13	16139-304	1	Set Screw	X	X	X	X	X	X	X	X
48-14	72400-505	1	Input Shaft	X	X	X	X	X	X	X	X
+ 48-15	16003-5	1	O-ring	X	X	X	X	X	X	X	X
+ 48-16	16074-106	1	Wiper Seal	X	X	X	X	X	X	X	X
48-17	72400-520	1	Headed Pin (press fit)	X	X	X	X	X	X	X	X
48-18	16003-6	2	O-ring		X		X		X		X
48-19	72420-AA	1	Destroke Valve Assy.		X		X		X		X
48-19-1	72400-522	1	Manifold		X		X		X		X
48-19-2		1	Destroke Valve								
	72400-521		w/12 VDC coil, Weatherpak Conn.		X		X		X		X
	72400-548		w/24 VDC coil, Weatherpak Conn.								
	72400-549		w/12 VDC coil, Din 43650 Conn.								
	72400-550		w/24 VDC coil, Din 43650 Conn.								
48-19-2A	16133-10	1	O-ring		X		X		X		X
48-19-2B	16101-102	2	Back-up Washer		X		X		X		X
48-19-2C	16015-2	1	O-ring		X		X		X		X
48-20	16045-103	2	Lock Washer		X		X		X		X
48-21	16147-316	2	Cap Screw		X		X		X		X
48-22	16133-8	1	O-ring		X	X					
48-23	72400-545	1	Adapter, Neutral Lockout		X	X					
48-24	16006-6	1	Ball		X	X					
48-25	16003-500	1	O-ring		X	X					
48-26	72400-546	1	Pin		X	X					
48-27	102149-019	1	#10-32, Set Screw		X	X					
48-28	102147	1	Neutral Lockout Switch		X	X					
48-29	98193	1	Ball Plunger					X	X		
48-30	101335	1	Nut, Seal					X	X		

Item 51, 52, or 53 - Orifice Sizes Available

Item 51, 52, or 53 Orifice Sizes Available

Part Number	Hole Dia. mm [inches]
101619-021	.53 [.021]
101619-028	.71 [.028]
101619-036	.91 [.036]
101619-040	1.02 [.040]
101619-044	1.12 [.044]
101619-048	1.22 [.048]
101619-052	1.32 [.052]
101619-057	1.45 [.057]
101619-065	1.65 [.065]
101619-073	1.85 [.073]
101619-094	2.38 [.094]
101619-102	2.59 [.102]

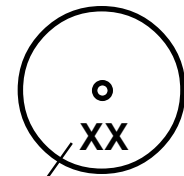

Last two digits
of dash number
stamped on face
of orifice.

Item 31 - Drive Shaft Identification

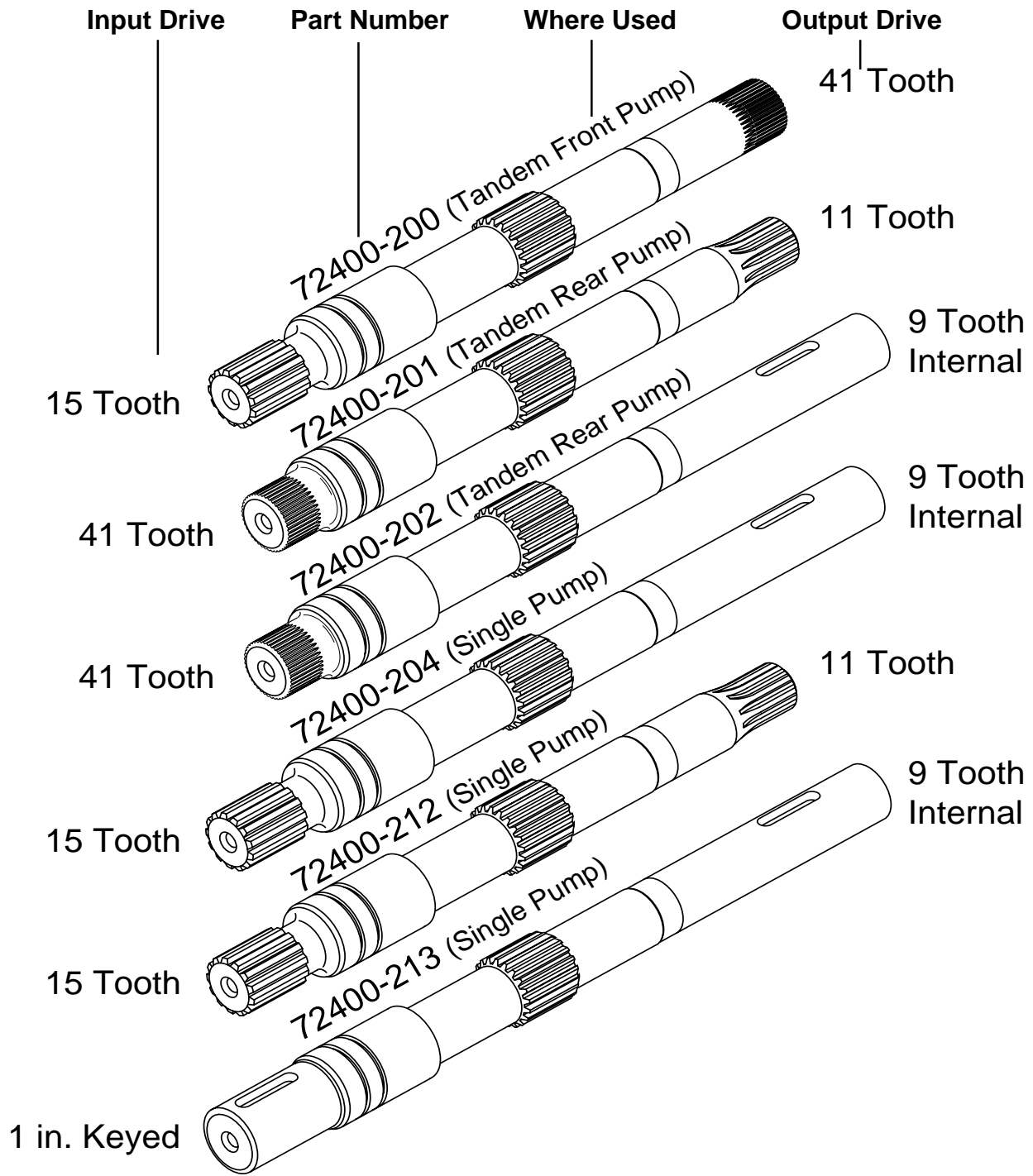

Each order must include the following information.

1. Product and/or Part Number
 2. Serial Number Code
 3. Part Name
 4. Quantity
-

Identification Numbers - Servo Control Piston Pump

Stamped on each units mounting flange.

- A - Product Number Discription
 - 72400 = Single Piston Pump
 - 78461 = Tandem Piston Pump
 - 78462 = Single or Tandem Piston Pump with Gear Pump
- B - Sequential Numbering
- C - Design Code Number

Single Pump - Product Number:

7 2 4 0 0 - 0 0 2 - 0 3
 A B C

Tandem Pumps - Product Number:

7 8 4 6 1 - 0 0 2 - 0 3
 A B C

Serial Number Code:

B 91 01 31 JB

- Revision level of parts list. ———|
- Last two digits of year built. ———| (91 for 1991 etc.)
- Month (two digits) ———|
- Day of Month (two digits) ———|
- Testers Initials ———|

Eaton
Fluid Power Group
Hydraulics Business USA
14615 Lone Oak Road
Eden Prairie, MN 55344
USA
Tel: 952-937-9800
Fax: 952-294-7722
www.eaton.com/hydraulics

Eaton
Fluid Power Group
Hydraulics Business Europe
Route de la Longeraie 7
1110 Morges
Switzerland
Tel: +41 (0) 21 811 4600
Fax: +41 (0) 21 811 4601

Eaton
Fluid Power Group
Hydraulics Business Asia Pacific
11th Floor Hong Kong New World Tower
300 Huaihai Zhong Road
Shanghai 200021
China
Tel: 86-21-6387-9988
Fax: 86-21-6335-3912