



# Hydraulics

## Heavy Duty Hydrostatic Transmissions

Troubleshooting Guide for  
Eaton Hydrostatic Transmissions

**Variable Displacement Pump**

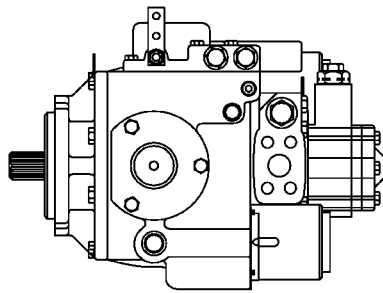

**Variable Displacement Motor**

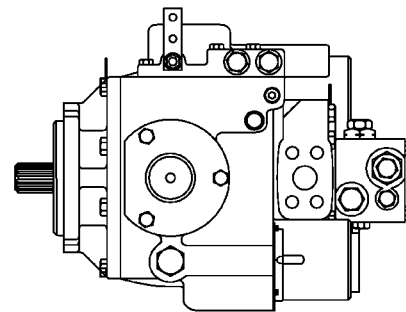

**Fixed Displacement Motor**

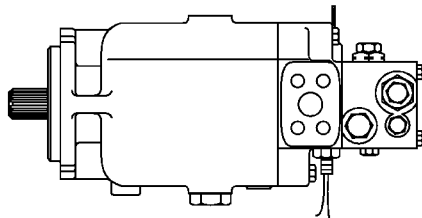

**Fixed Displacement Motor  
(With Integral Shuttle)**

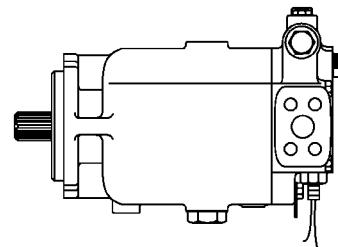

# Contents

Introduction ..... 2  
Typical Hydrostatic System ..... 3  
Gauge Requirements, Gauge Port Size and Locations ..... 4-5  
Typical Pressure Readings ..... 6  
Fault-Logic Troubleshooting ..... 7-11  
Action Step Comments ..... 12-13  
Hydraulic Fluid Recommendations ..... 14-15

# Introduction

This manual provides troubleshooting information for a typical hydrostatic system. It will help you to diagnose minor problems that may occur with Eaton Heavy Duty Hydrostatic Transmissions.

The following publications are also available for Eaton Heavy Duty Hydrostatic Transmissions:

Technical Data for Hydrostatic Closed-Circuit Schematics  
..... No. 3-403

Eaton Heavy Duty Hydrostatic Start-Up Procedure  
..... No. 2-402

Eaton Hydrostatic Variable Pump Repair Manual (Series 0)  
..... No. 7-603

Eaton Hydrostatic Variable Pump Repair Manual (Series 1)  
..... No. 7-606

Eaton Hydrostatic Fixed Pump Repair Manual (Series 0)  
..... No. 7-122

Eaton Hydrostatic Fixed Pump Repair Manual (Series 1)  
..... No. 7-127

Eaton Hydrostatic Variable Motor Repair Manual (Series 0)  
..... No. 7-121

Eaton Hydrostatic Variable Motor Repair Manual (Series 1)  
..... No. 7-140

# Typical Hydrostatic System

Variable Pump-Fixed Motor

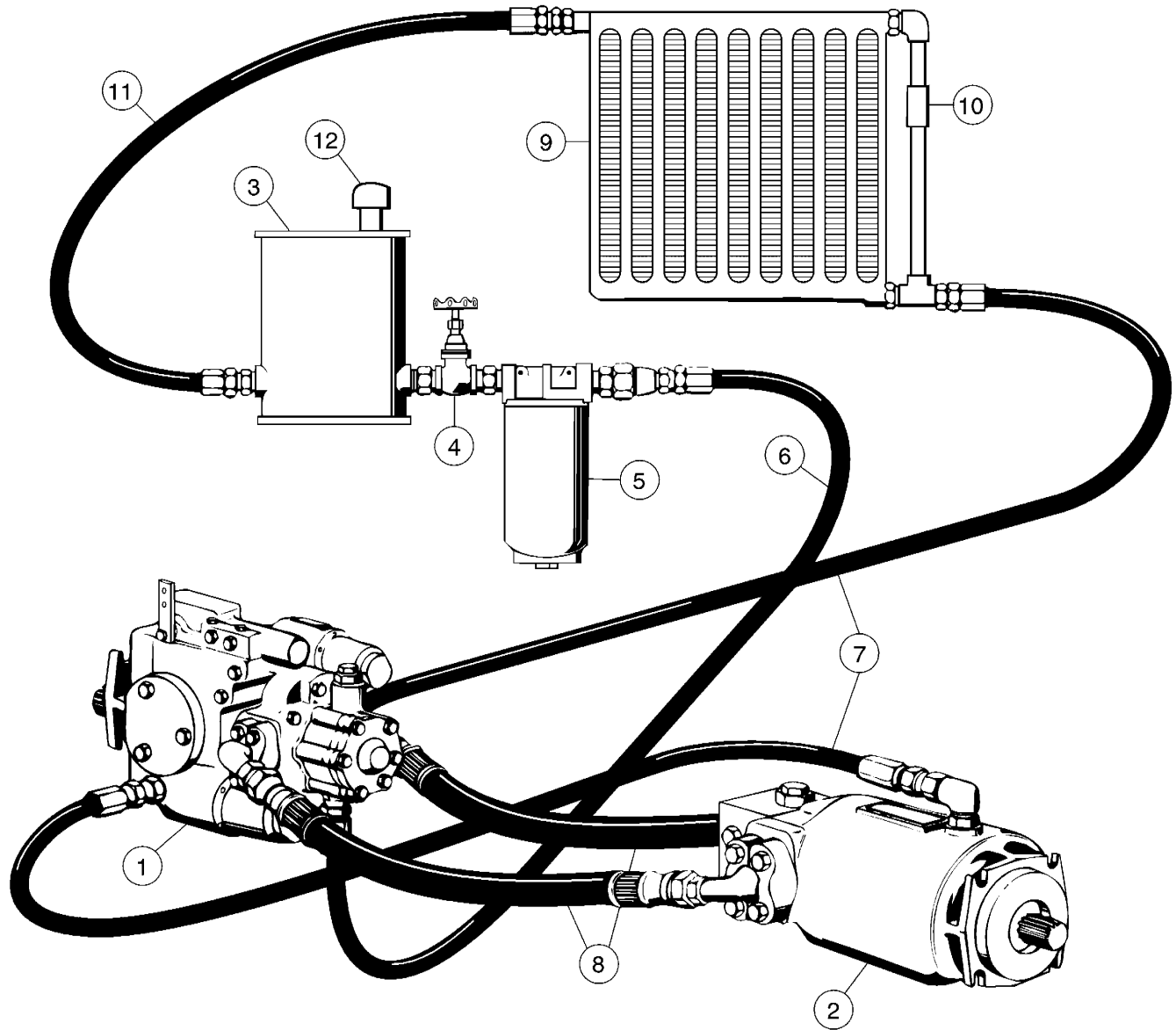

- 1 Variable Displacement Pump
- 2 Fixed or Variable Displacement Motor
- 3 Reservoir
- 4 Shut-off Valve (Optional)
- 5 Filter
- 6 Charge Pump Inlet Line

- 7 Pump and Motor Case Drain Lines
- 8 High Pressure Lines
- 9 Heat Exchanger
- 10 Heat Exchanger By-pass Valve
- 11 Reservoir Return Line
- 12 Reservoir fill Cap and Breather

## Gauge Requirements, Gauge Port Size and Locations Variable Displacement Pumps

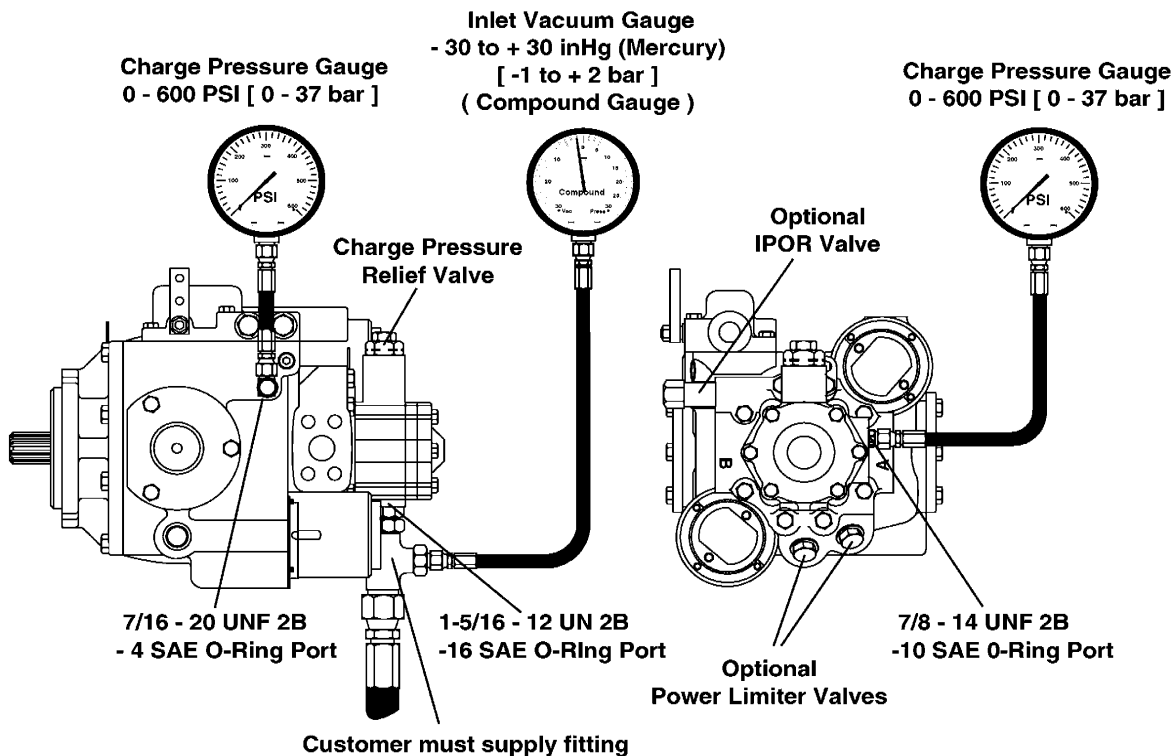

## Fixed Displacement Motors

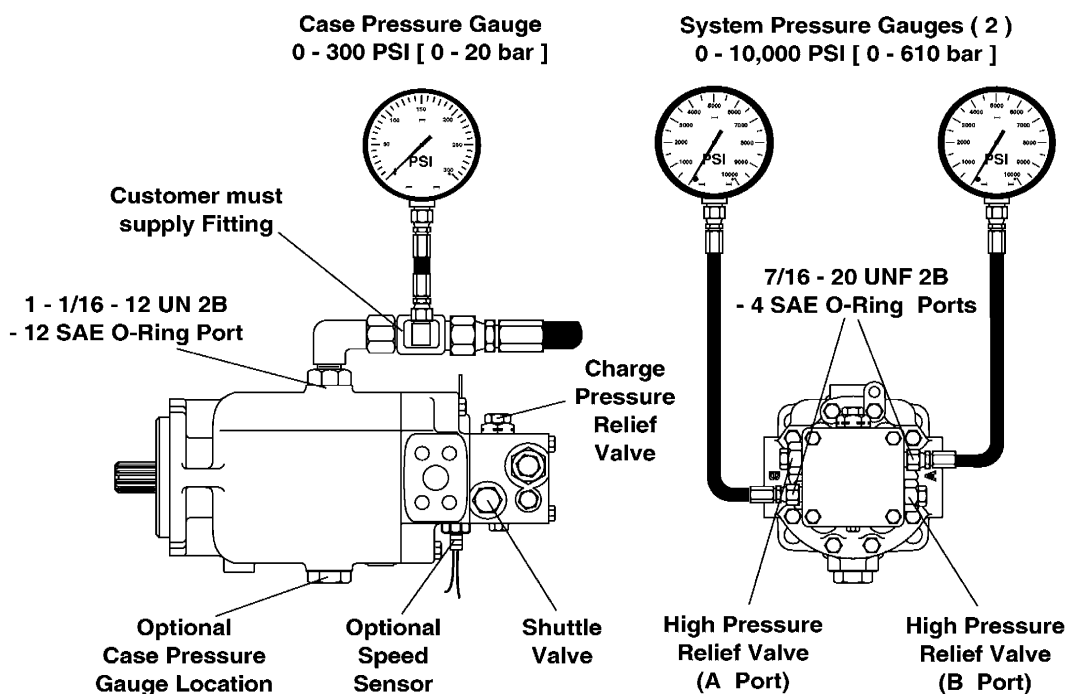

## Gauge Requirements, Gauge Port Size and Locations Fixed Displacement Motors (with Integral Shuttle)

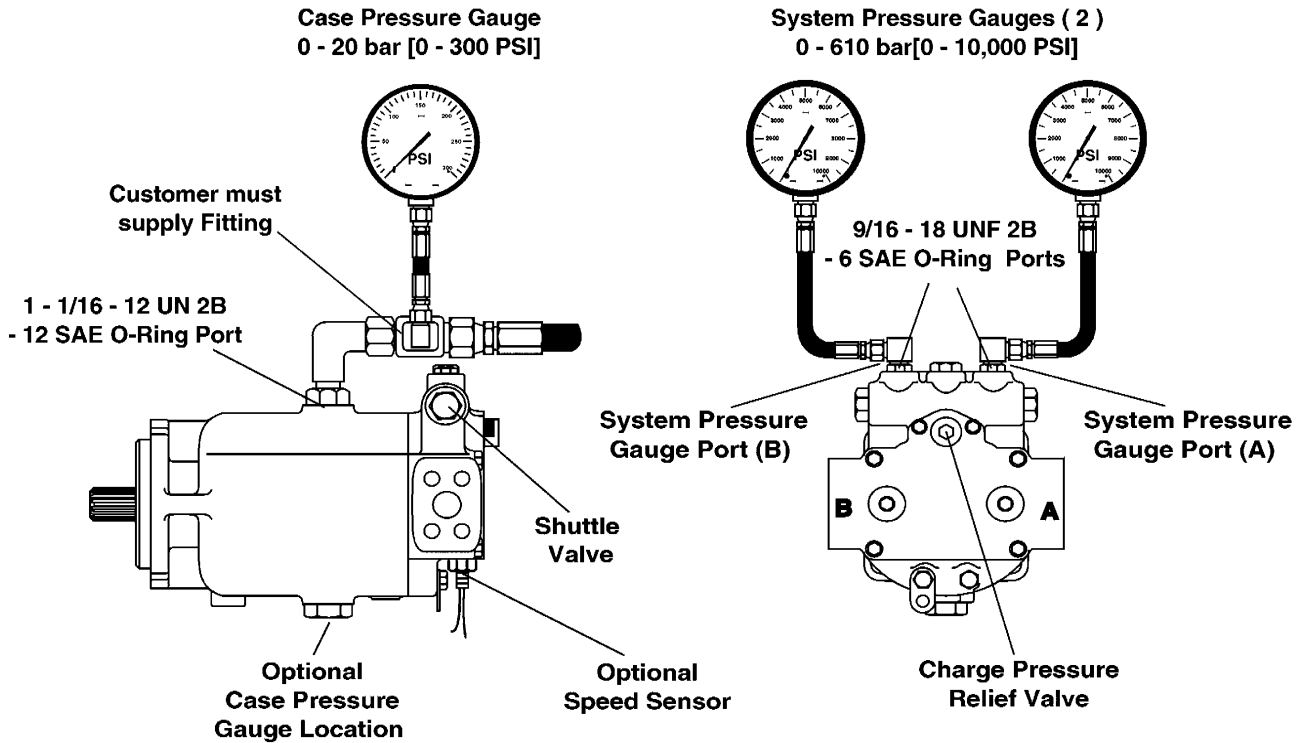

## Variable Displacement Motors

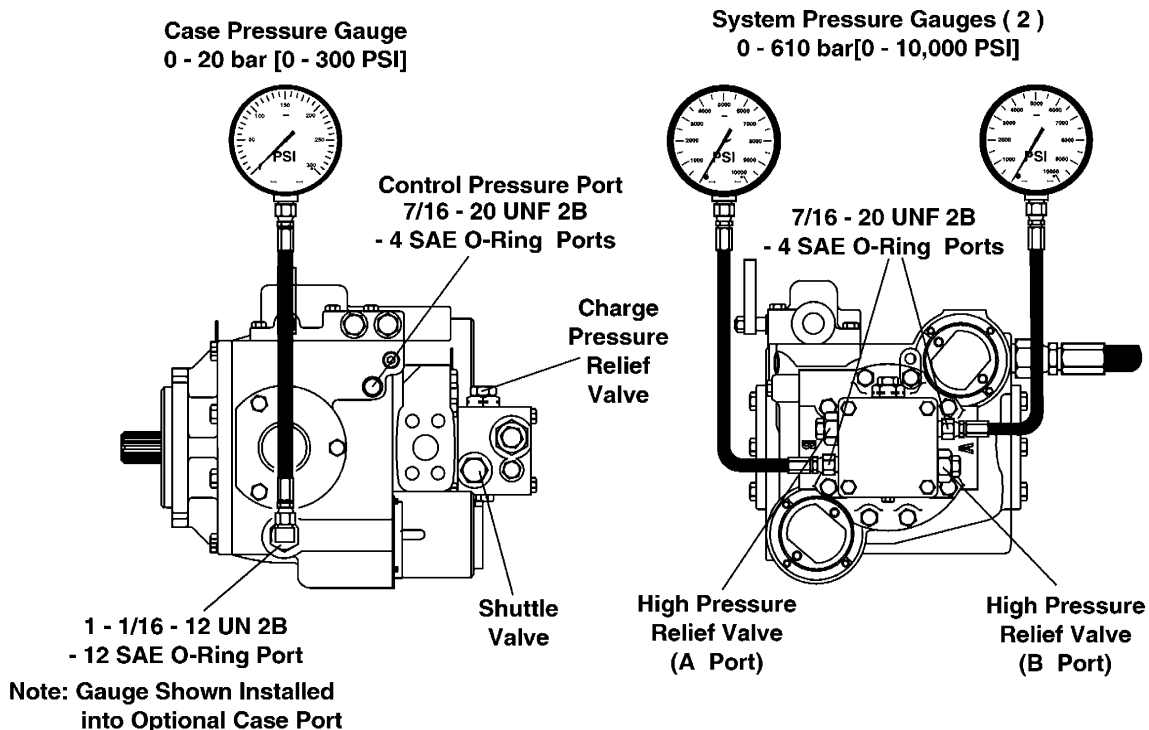

**Note: To protect your instrumentation, all gauges should be dampened (or snubbed) and mounted with flexible lines.**

## Pressure Readings

The pressures given in this manual are gauge pressures or delta pressures. A pressure gauge reads zero when connected to atmospheric pressure. Any reading above or below this zero point is referred to as gauge pressure (bar [PSI]). Delta pressure is the difference of two gauge pressures in a hydraulic circuit.

**Example:**

- Charge pressure reading of 16,5 bar [240 PSI]
- Case pressure reading of 1,5 bar [20 PSI]
- Differential pressure of 15,0 D bar [220 D PSI]

Typical hydrostatic circuits usually include a inlet pressure, case pressure, low or charge pressure and system or high pressure. These pressures will vary per each individual application and operating conditions.

### Nominal Operating Pressures

(At Normal Operating Temperature)

Inlet Vacuum: Should not exceed 254 mm [10 in.] mercury (Hg.) for an extended period of time

Case pressure: Should not exceed 2,8 bar [40 PSI] for an extended period of time

Charge Pressure:\* Neutral 15,2 bar [220 PSI]  
Forward or Reverse 11,0 bar [160 PSI]

\*Charge Pressure Relief valves are factory preset to their nominal setting with a 7,6 l/min [2 GPM] flow rate. The original valve pressure will increase approximately ,45 bar per 3,8 l/min [6.5 PSI per 1 GPM] additional flow over the valve. The charge pressures given above are typical. Higher charge pressures may be set at the factory for your particular application.

# Fault-Logic Troubleshooting

This guide is designed as a diagnostic aid for the user to locate possible transmission problems. Match the transmission symptoms with the problem statements and follow the action steps shown in the box diagrams. This will help in correcting minor problems, eliminating unnecessary mixer down time.

Following the fault-logic diagrams are diagram action comments to further help explain the action steps shown in the diagrams. Where applicable, the action comment number of the statement appears in the action block of the diagram.

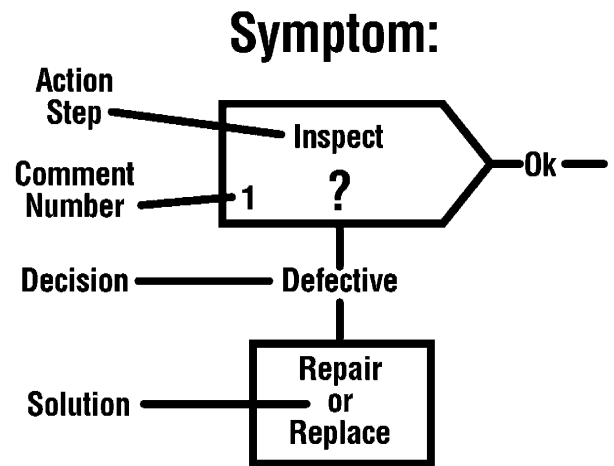

## Neutral Difficult or Impossible to Find

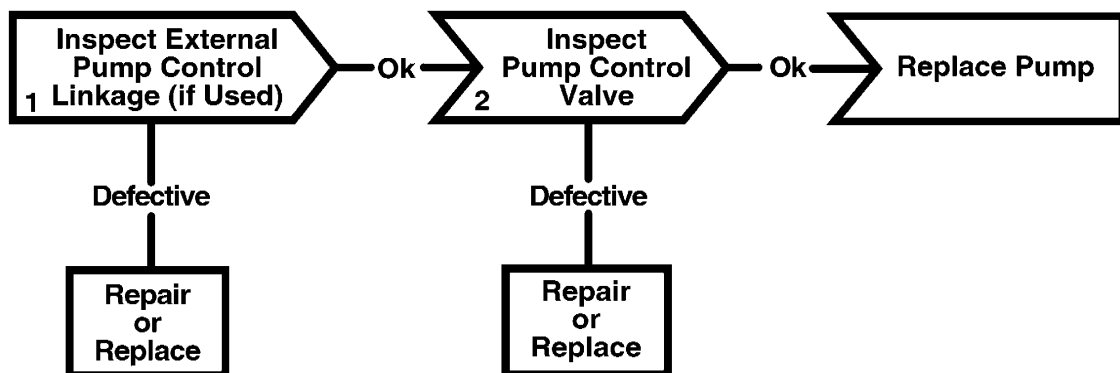

# Transmission Operates in One Direction Only

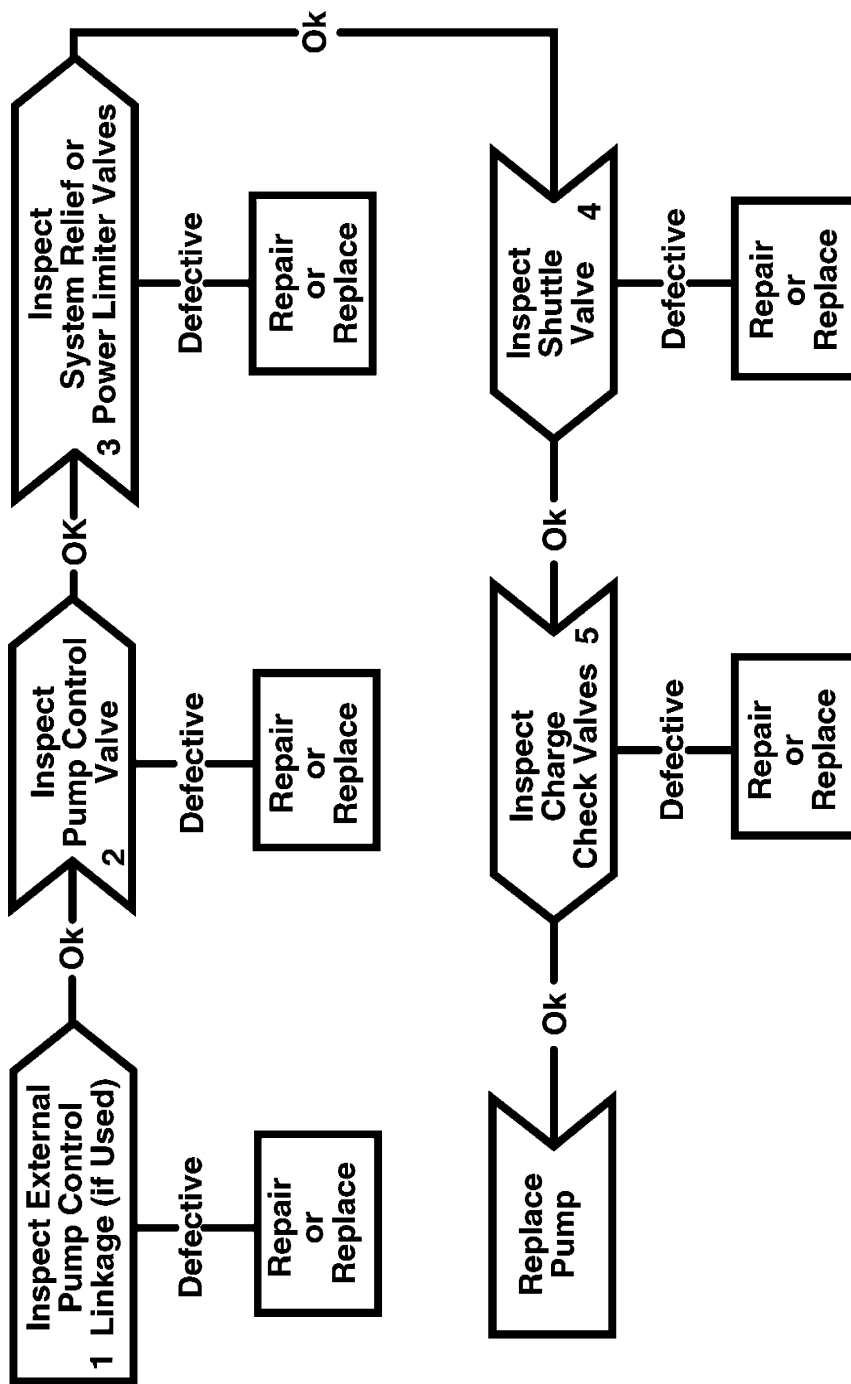





# System Response Sluggish

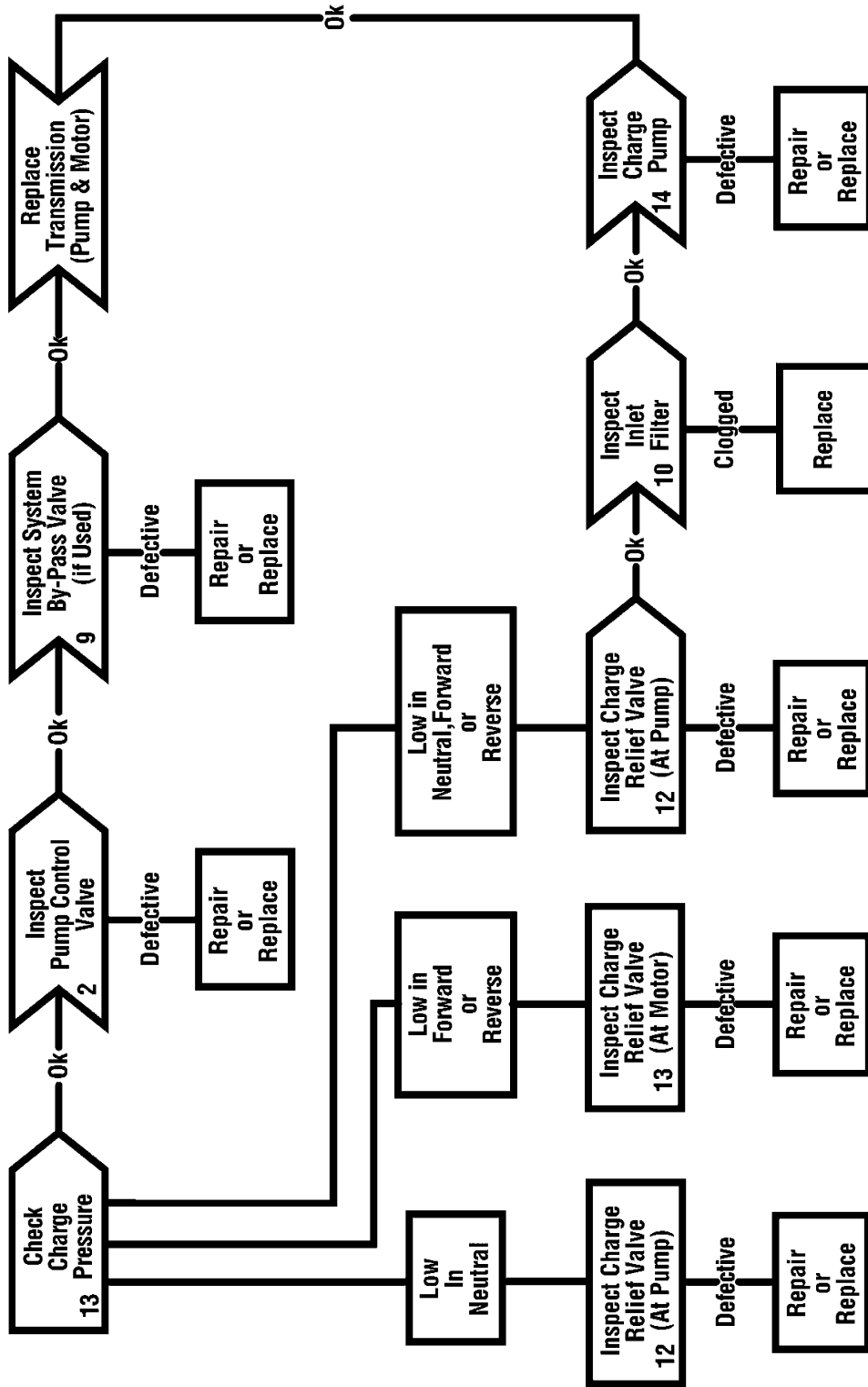

# System Will Not Operate in Either Direction

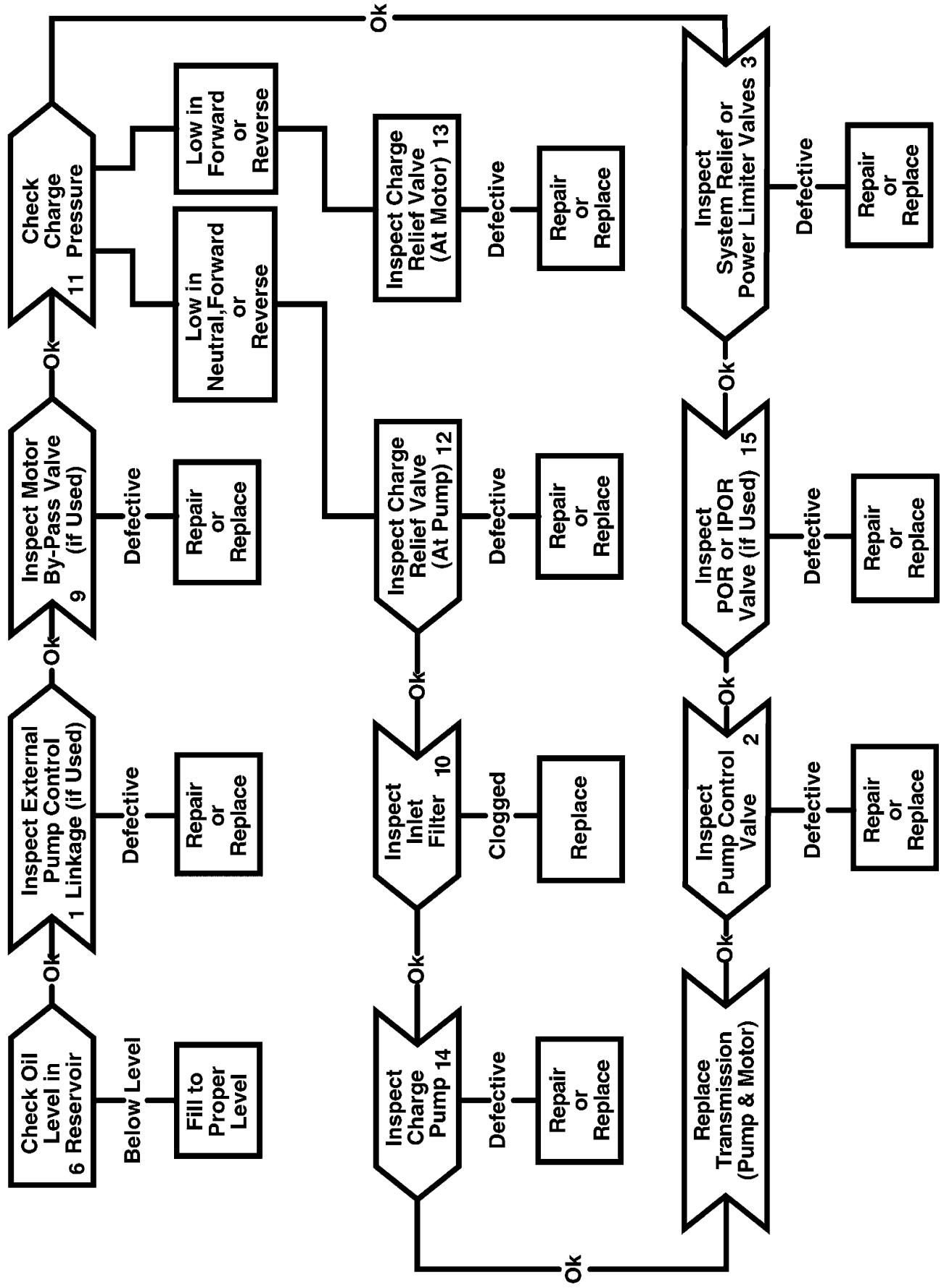

# Diagram Action Step Comments

1. Inspect External Pump Control Linkage for:
  - (Manual Operated Controls)
  - A. Misadjusted or disconnected
  - B. Binding, bent or broken
  
  - (Hydraulic Remote Controls)
  - A. Improper pilot pressure
  - B. Defective proportional valve  
(See proportional valve manual for repairs.)
  
  - (Electrical Operated Controls)
  - A. Disconnected electrical signal connection
2. Inspect Pump Control Valve for:
  - (Manual Operated Controls)
  - A. Plugged control orifice
  - B. Damaged mounting gasket
  - C. Misadjusted, damaged or broken neutral return spring
  - D. Broken control connector pin
  - E. Broken or missing control linkage pin(s)
  - F. Galled, stuck or bent control spool
  
  - (Hydraulic Remote Controls)
  - A. Plugged control orifice
  - B. Damaged mounting gasket
  - C. Misadjusted, damaged or broken neutral return spring (2)
  - D. Broken control connector pin
  - E. Broken or missing control linkage pin(s)
  - F. Galled, stuck or bent control spool
  
  - (Electrical Operated Controls)
  - A. Plugged control orifice
  - B. Damaged mounting gasket
  - C. Galled, stuck or bent control spool
  - D. Stuck solenoid valve(s)
  - E. Defective solenoid coil(s)
  - F. Misadjusted speed sensor (when used)
  - G. Defective speed sensor (when used)
  - H. Defective electronics module

NOTE: When the electronic transit mixer control is used, follow the control box fault detector instructions.
3. Inspect System Relief or Power Limiter Valves for:
  - (System Relief Valves)
  - A. Improper pressure relief setting  
(Consult owners/operator manual for system relief valve settings)
  - B. Damaged or missing O-ring and/or back-up ring(s)
  - C. Plugged orifice
  - D. Piston galled or stuck
  - E. Valve poppet held off seat
  
  - (Power Limiter Valves)
  - A. Improper pressure relief setting  
(Consult owners/operator manual for power limiter valve setting.)
  - B. Broken spring
  - C. Valve held off seat
4. Inspect Shuttle Valve for:
  - A. Bent or broken return centering spring
  - B. Galled or stuck shuttle spool
  - C. Bent or broken shuttle spool
5. Inspect Charge Check Valves for:
  - A. Damaged or missing O-ring and/or back-up ring(s)
  - B. Damaged check ball seat
  - C. Stuck check ball
6. Check Oil Level in Reservoir:
  - A. Consult owner/operators manual for the proper type fluid and level.
7. Inspect Heat Exchanger for:
  - A. Obstructed air flow (air cooled)
  - B. Obstructed water flow (water cooled)
  - C. Improper Plumbing (inlet to outlet)
  - D. Obstructed or insufficient fluid flow
  - E. Cooling fan failure (if used)
8. Inspect Heat Exchanger By-Pass Valve for:
  - A. Improper pressure setting
  - B. Stuck or broken valve
9. Inspect Motor By-Pass Valve for:
  - A. Valve held in partial and/or open position

10. Inspect Inlet Filter for:
  - A. Plugged or clogged filter
  - B. Obstructed inlet or outlet
  - C. Collapsed inlet line to charge pump
  - C. Open inlet to charge pump
11. \*Check Charge Pressure:
  - A. Consult page 4 in this manual for charge pressure gauge installation location.
  - B. Consult owner/operators manual for charge relief valve settings.
12. \*Inspect Charge Relief Valve for: (at Pump)
  - A. Improper charge relief pressure setting
  - B. Plugged Orifice
  - C. Piston galled or stuck open and/or closed
  - D. Damaged or missing O-ring
  - E. Valve poppet held off seat
13. \*Inspect Charge Relief Valve for: (at Motor)
  - A. Improper charge relief pressure setting
  - B. Plugged Orifice
  - C. Piston galled or stuck open and/or closed
  - D. Damaged or missing O-ring
  - E. Valve poppet held off seat
14. Inspect Charge Pump for: (Standard and A-Pad Pumps)
  - A. Broken drive tang
  - B. Damaged or missing o-ring(s)
  - C. Broken drive key
  - D. Galled or broken gerotor set

(B-Pad Pumps)

  - A. Stripped or broken drive coupling
  - B. Stripped or broken drive spline
  - C. Damaged or missing o-ring(s)
  - D. Broken drive key
  - E. Galled or broken gerotor set

15. Inspect POR or IPOR for: (POR, Pressure Override)
  - A. Plugged orifice
  - B. Misadjustment of maximum pressure setting
  - C. Stuck or missing check ball
  - D. Stuck or broken sensing pin
  - E. Stuck or broken control spool
  - F. Obstructed or broken sensing line

(IPOR, Internal Pressure Override)

  - A. Plugged orifice
  - B. Misadjustment of maximum pressure setting
  - C. Load sensing pins reversed
  - D. Stuck or broken sensing pin
  - E. Stuck or broken control spool

## Diagram Action Step Comments

### \*System / Charge Relief Valve Pressure Setting Identification

The system and charge pressure relief valves are all factory preset. For identification, a pressure code is stamped on the hex plug located on the end of the system and charge pressure valve cartridges.

This same code is also used on the power limiter valves. The code number is stamped on the end of the valve cartridge. (Power limiter valves must be removed to view pressure code.) To determine the pressure setting of each valve, add a zero to the right of the stamped coded number.

### Charge Pressure Valve Examples

016 = 11,0 bar [160 PSI] Setting  
022 = 15,2 bar [220 PSI] Setting

### System and Power Limiter Valve Pressure Examples

400 = 275 bar [4000 PSI] Setting  
500 = 345 bar [5000 PSI] Setting

# Hydraulic Fluid Recommendations

## Introduction

The ability of Eaton hydraulic components to provide desired performance and life expectancy depends largely on the fluid used. The purpose of this document is to provide readers with the knowledge required to select the appropriate fluids for use in systems that employ Eaton hydraulic components.

One of the most important characteristic to consider when choosing a fluid to be used in a hydraulic system is **viscosity**. Viscosity choice is always a compromise; the fluid must be thin enough to flow easily but thick enough to seal and maintain a lubricating film between bearing and sealing surfaces. Viscosity requirements for each of Eaton's product lines are given on the back of this document.

## Viscosity and Temperature

Fluid temperature affects viscosity. In general, as the fluid warms it gets thinner and its viscosity decreases. The opposite is true when fluid cools. When choosing a fluid, it is important to consider the start-up and operating temperatures of the hydraulic system. Generally, the fluid is thick when the hydraulic system is started. With movement, the fluid warms to a point where a cooling system begins to operate. From then on, the fluid is maintained at the temperature for which the hydraulic system was designed. In actual applications this sequence varies; hydraulic systems are used in many environments from very cold to very hot. Cooling systems also vary from very elaborate to very simple, so ambient temperature may affect operating temperature. Equipment manufacturers who use Eaton hydraulic components in their products should anticipate temperature in their designs and make the appropriate fluid recommendations to their customers.

## Cleanliness

Cleanliness of the fluid in a hydraulic system is extremely important. Eaton recommends that the fluid used in its hydraulic components be maintained at ISO Cleanliness Code 18/13 per SAE J1165. This code allows a maximum of 2500 particles per milliliter greater than 5  $\mu\text{m}$  and a maximum of 80 particles per milliliter greater than 15  $\mu\text{m}$ . When components with different cleanliness requirements are used in the same system, the cleanest standard should be applied. OEM's and distributors who use Eaton hydraulic components in their products should provide for these requirements in their designs. A reputable filter supplier can supply filter information.

## Fluid Maintenance

Maintaining correct fluid viscosity and cleanliness level is essential for all hydraulic systems. Since Eaton hydraulic components are used in a wide variety of applications it is impossible for Eaton to publish a fluid maintenance schedule that would cover every situation. Field testing and monitoring are the only ways to get accurate measurements of system cleanliness. OEM's and distributors who use Eaton hydraulic components should test and establish fluid maintenance schedules for their products. These maintenance schedules should be designed to meet the viscosity and cleanliness requirements laid out in this document.

## Fluid Selection

Premium grade petroleum based hydraulic fluids will provide the best performance in Eaton hydraulic components. These fluids typically contain additives that are beneficial to hydraulic systems. Eaton recommends fluids that contain anti-wear agents, rust inhibitors, anti-foaming agents, and oxidation inhibitors. Premium grade petroleum based hydraulic fluids carry an ISO VG rating.

SAE grade crankcase oils may be used in systems that employ Eaton hydraulic components, but it should be noted that these oils may not contain all of the recommended additives. This means using crankcase oils may increase fluid maintenance requirements.

Hydraulic fluids that contain V.I. (viscosity index) improvers, sometimes called multi-viscosity oils, may be used in systems that employ Eaton hydraulic components. These V.I. improved fluids are known to "shear-down" with use. This means that their actual viscosity drops below the rated value. Fluid maintenance must be increased if V.I. improved fluids are used. Automotive automatic transmission fluids contain V.I. improvers.

Synthetic fluids may be used in Eaton hydraulic components. A reputable fluid supplier can provide information on synthetic fluids. Review applications that require the use of synthetic fluids with your Eaton representative.

## Viscosity Requirements

Product Line	Minimum	Optimum Range	Maximum	ISO Cleanliness Requirements	Comments
Heavy Duty Piston Pumps and Motors	60 SUS [10 cSt]	80 - 180 SUS [16 - 39 cSt]	10,000 SUS [2158 cSt]	18/13	

### Additional Notes:

- Fluids too thick to flow in cold weather start-ups will cause pump cavitation and possible damage. Motor cavitation is not a problem during cold start-ups, except for two speed motors. Thick oil can cause high case pressures which in turn can blow motor shaft seals.
- When choosing a hydraulic fluid, all the components in the system must be considered and the optimum viscosity range adjusted accordingly. For example, when a medium duty piston pump is combined with a Geroler motor the optimum viscosity range becomes 100 - 150 SUS [20 - 32 cSt] and viscosity should never fall below 70 SUS [13 cSt].
- If the natural color of the fluid has become black it is possible that an overheating problem exists.
- If the fluid becomes milky, water contamination may be a problem.
- Take fluid level reading when the system is cold.
- Contact your Eaton representative if you have specific questions about the fluid requirements of Eaton hydraulic components.

**Eaton**  
Fluid Power Group  
Hydraulics Business USA  
14615 Lone Oak Road  
Eden Prairie, MN 55344  
USA  
Tel: 952-937-9800  
Fax: 952-294-7722  
[www.eaton.com/hydraulics](http://www.eaton.com/hydraulics)

**Eaton**  
Fluid Power Group  
Hydraulics Business Europe  
Route de la Longeraie 7  
1110 Morges  
Switzerland  
Tel: +41 (0) 21 811 4600  
Fax: +41 (0) 21 811 4601

**Eaton**  
Fluid Power Group  
Hydraulics Business Asia Pacific  
11th Floor Hong Kong New World Tower  
300 Huaihai Zhong Road  
Shanghai 200021  
China  
Tel: 86-21-6387-9988  
Fax: 86-21-6335-3912