

Char-Lynn[®]

General Purpose Hydraulic Motors

March, 1996



Repair Information

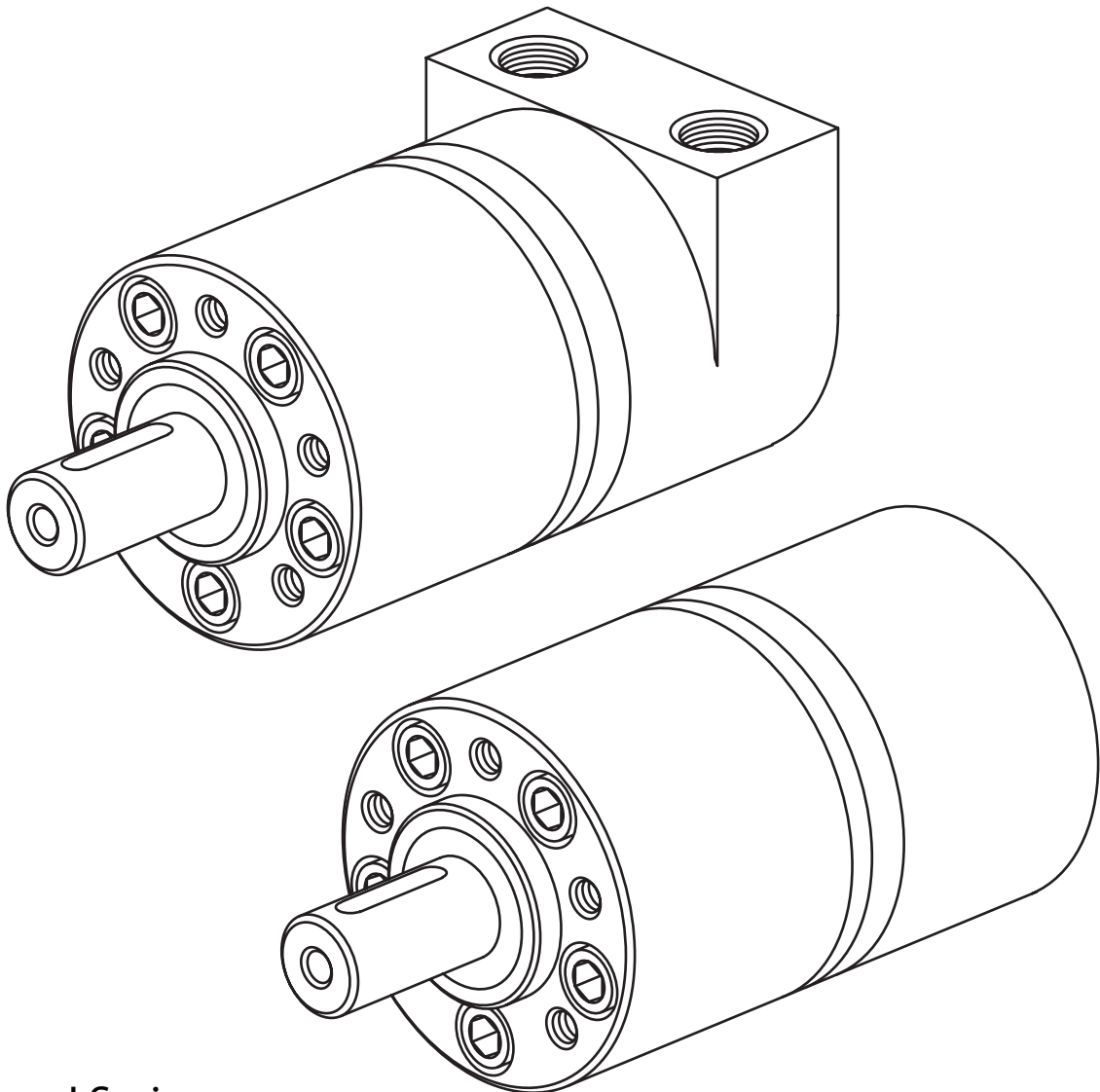

J Series
Geroler[®] Motor

001 002

J Series Geroler Motors

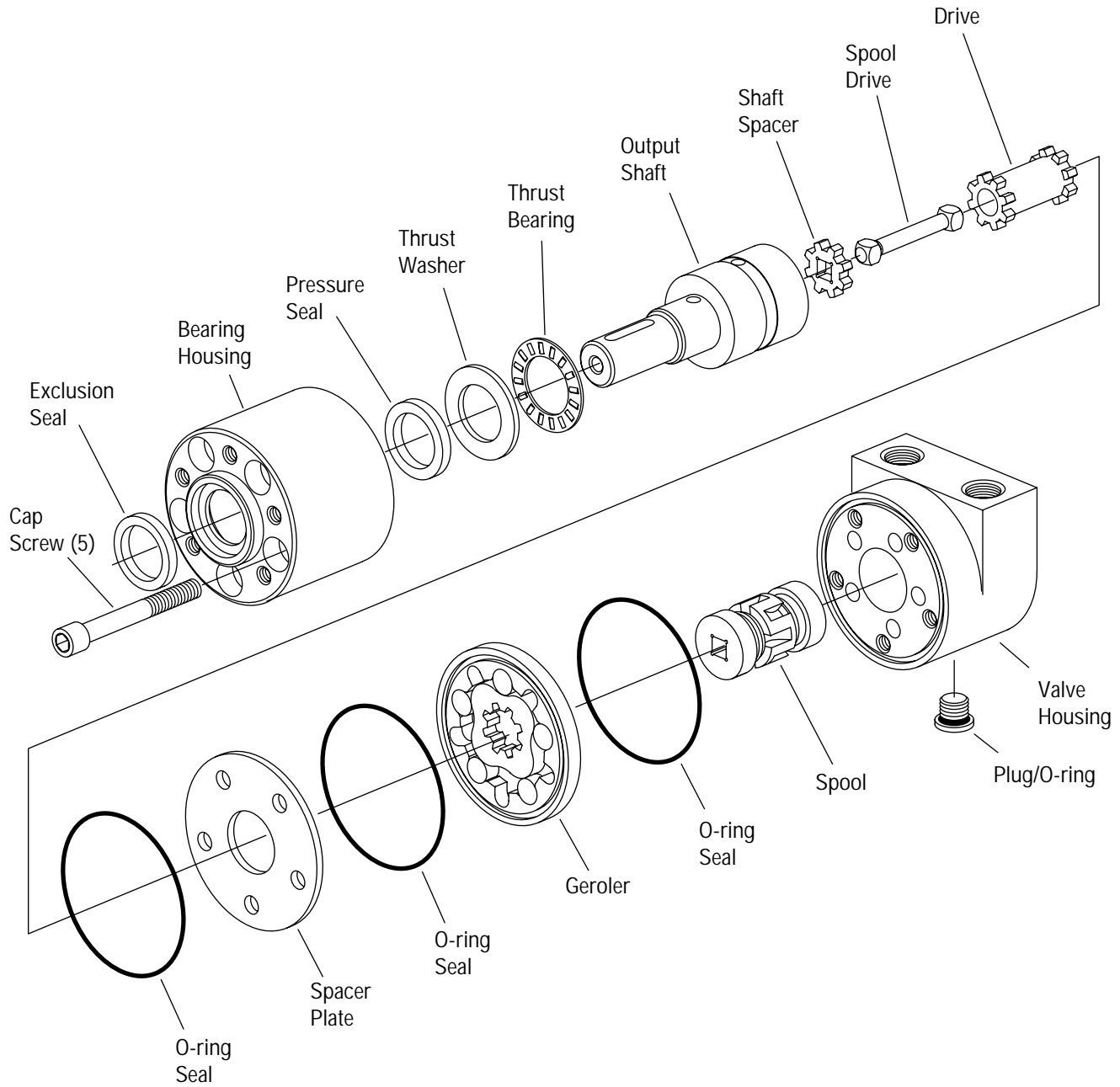

Required Tools

- 1/8 in. hex key
- 3/16 in. hex key
- 5 mm hex key (for motors with metric ports)
- Torque wrench - 17 Nm [150 lb-in.] capacity

J Series Geroler Motors

1 Cleanliness is extremely important when repairing hydraulic motors. Work in a clean area. Before disconnecting the hydraulic lines, clean the port area of the motor. Before disassembly, drain the oil from the motor. Then plug the ports and thoroughly clean the exterior of the motor. Check the output shaft, remove any burrs, nicks, or sharp edges.

2 Make a scribe mark across the motor sections. This will help get the correct alignment when the motor is reassembled.

3 Remove the five cap screws and disassemble the motor as shown in the parts drawing.

Note: Do not remove the retaining rings and check balls from the spool.

4 Carefully remove the exclusion seal and pressure seal from the bearing housing. A seal removal tool may be fabricated by bending and rounding the end of a small blade screwdriver, see figure 1.

Important: Do not damage the bearing housing.

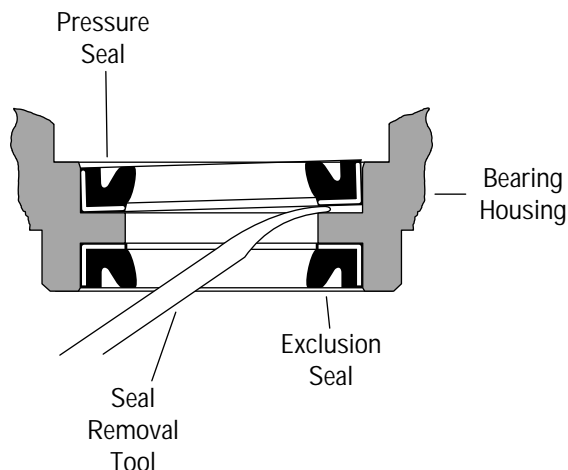

Figure 1

5 Check all mating surfaces. Replace any parts with scratches or burrs that could cause leakage. Wash all metal parts in clean solvent. Blow them dry with pressurized air. Do not wipe parts dry with paper towels or cloth. Lint in a hydraulic system will cause damage. Check the key way and chamfered area of the output shaft; remove any nicks, burrs, or sharp edges that could damage the shaft seals during reassembly.

Note: Always use new seals when reassembling hydraulic motors. Refer to Parts List 6-147 for seal kit part numbers, replacement parts, and ordering information.

Important: During reassembly lubricate the new seals with a petroleum jelly like Vaseline. Also lubricate machined surfaces and bearings with clean hydraulic fluid.

6 Put the thrust bearing and thrust washer on the output shaft.

7 Apply a light coating of hydraulic fluid to the outside diameter of the pressure seal and carefully slide it onto the shaft so that it is next to the thrust washer. See figure 1 for the correct seal orientation.

Note: The pressure seal is slightly thicker than the exclusion seal.

8 Slide the shaft into the bearing housing and press the pressure seal into its seat.

9 Remove the shaft, and thrust bearing and washer.

10 Using a 1 inch diameter dowel, press the pressure seal all the way into its seat. Be careful, do not damage the seal.

11 Install the exclusion seal. Be sure to press it all the way into the seat. See figure 1 for the correct seal orientation.

12 Apply a coating of Mobilith SCH 220, or equivalent to inner edges of the shaft seals.

13 Install the thrust bearing and washer onto the output shaft. Dip the bearing end of the output shaft, thrust bearing and washer in clean hydraulic fluid. Then carefully slide the output shaft into the bearing housing.

Important: Do not damage the shaft seals, use of a protective bullet is recommended.

14 Install the shaft spacer, spool drive, and drive. The end of the drive with the small opening goes into the output shaft.

15 Lightly lubricate and install an o-ring seal in the groove in the bearing housing.

16 Install the spacer plate and align the screw holes.

17 Lightly lubricate and install an o-ring seal in the groove in the Geroler.

J Series Geroler Motors

18 Install the Geroler and time the motor.

- Align the corners of the spool drive end with the star points for standard timing, see figure 2.
- Align the corners of the spool drive end with the star valleys for reverse timing, see figure 2.

19 Align the screw holes in the geroler with the screw holes in the bearing housing and spacer plate.

20 Lubricate the spool and slide it into the valve housing.

Note: The spool is match fit to the valve housing, replace them as a subassembly.

21 Lubricate and install an o-ring seal in the groove in the valve housing.

22 Carefully install the valve housing and spool. Engage the spool with the spool drive, then rotate the valve housing until the scribe marks on the bearing and valve housings align.

23 Install the five cap screws and pretorque them in a criss-cross pattern to 9-10 Nm [80-90 lb-in.]. Final torque in a crisscross pattern to 14-15 Nm [120-130 lb-in.].

22 If no case drain is used, Install the plug in the valve housing. Use a new o-ring and tighten it to 7 Nm [60 lb-in.].

23 If a 2 bolt mounting flange is used, install the flange and tighten the screws, in a criss-cross pattern, to 8 - 10 Nm [71 - 89 lb-in.].

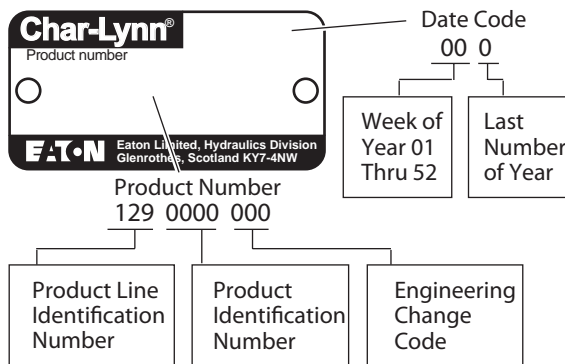
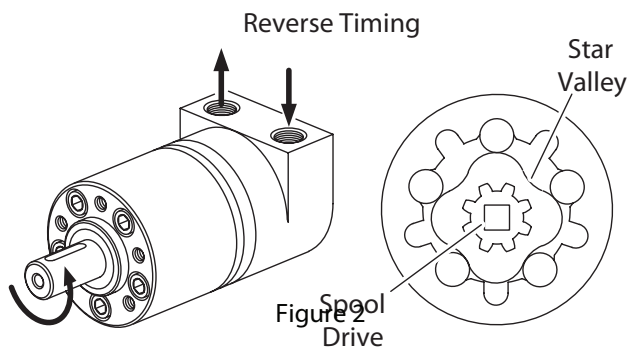
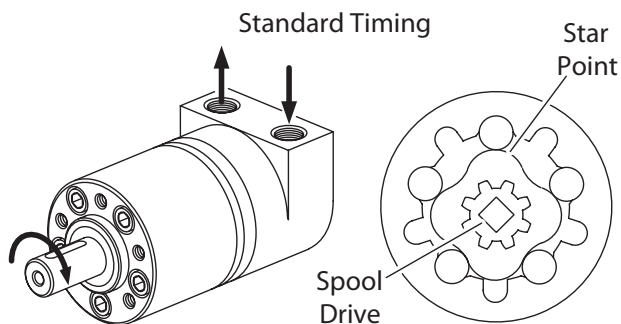

How to Order Parts

Each order must include the following information:

- 1 Product Number
- 2 Date Code
- 3 Part Name
- 4 Part Number
- 5 Quantity

Eaton
Fluid Power Group
Hydraulics Business USA
14615 Lone Oak Road
Eden Prairie, MN 55344
USA
Tel: 952-937-9800
Fax: 952-294-7722
www.eaton.com/hydraulics

Eaton
Fluid Power Group
Hydraulics Business Europe
Route de la Longeraie 7
1110 Morges
Switzerland
Tel: +41 (0) 21 811 4600
Fax: +41 (0) 21 811 4601

Eaton
Fluid Power Group
Hydraulics Business Asia Pacific
11th Floor Hong Kong New World Tower
300 Huaihai Zhong Road
Shanghai 200021
China
Tel: 86-21-6387-9988
Fax: 86-21-6335-3912