

**EAT•N**

**Char-Lynn**

**Disc Valve Motors**

Integral Cross Over Relief Valve

Technical Manual

2000 Series



**Char-Lynn®**

# Introduction



Eaton Char-Lynn®, your proven low speed high torque motor supplier, now offers the Char-Lynn® 2000 Series motor with our proven Eaton Vickers® Screw-in Cartridge Valves integral to the motor. This compact and efficient package offers increased value and cost effectiveness to designing Eaton into your applications. Minimizing the use of hoses, tubing, and fittings will reduce production and assembly time significantly.

## 2000 Series

|                         |                                       |
|-------------------------|---------------------------------------|
| Geroler® Element .....  | 9 Displacements                       |
| Flow LPM [GPM].....     | 75 [20] Cont.**<br>115 [30] Inter.*   |
| Speed .....             | Up to 924 RPM                         |
| Pressure Bar [PSI]..... | 200 [3000] Cont.<br>300 [4500] Inter. |
| Torque Nm [lb-in] ..... | 845 [7470] Cont.<br>930 [8225] Inter. |

\*\* Continuous— (Cont.) Continuous rating, motor may be run continuously at these ratings.

\* Intermittent— (Inter.) Intermittent operation, 10% of every minute.

## Features and Benefits

- Complete packaged system solution, single source for motor with relief valve capability
- Relief valves as close to the Geroler® as possible, providing added protection.
- Eliminate leak points from in-line or bolt-on relief's
- Valves capable of full motor flow and full motor pressure.
- Provides added flexibility to system design by allowing motors to have individual relief valve settings.
- Simplifies assembly, purchasing, and system design requirements

## Applications

- Skid Steer Attachments
- Swing Motor
- Brush Cutters & Mowers
- Harvesting Equipment
- Directional Boring

Any place pressure relief protection is optimal for system or motor performance and life

Replacement cartridges can be obtained by ordering the Item Part Number as listed below.

| ITEM PART # | ITEM DESC.          | RELIEF VALVE SETTING |
|-------------|---------------------|----------------------|
| 02-199291   | RV5A-10-F-0-35/15   | 1500 PSI             |
| 02-199292   | RV5A-10-F-0-35/17.5 | 1750 PSI             |
| 02-199293   | RV5A-10-F-0-35/20   | 2000 PSI             |
| 02-199295   | RV5A-10-F-0-35/22.5 | 2250 PSI             |
| 02-198563   | RV5A-10-F-0-35/25   | 2500 PSI             |
| 02-199294   | RV5A-10-F-0-35/27.5 | 2750 PSI             |
| 02-199296   | RV5A-10-F-0-35/30   | 3000 PSI             |

# Standard Mount Motors

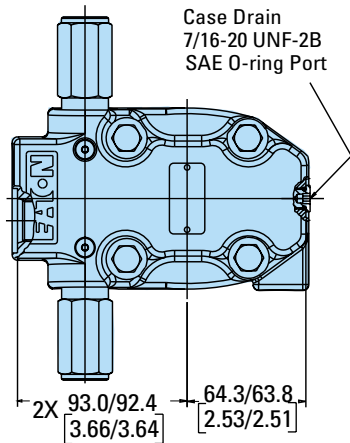
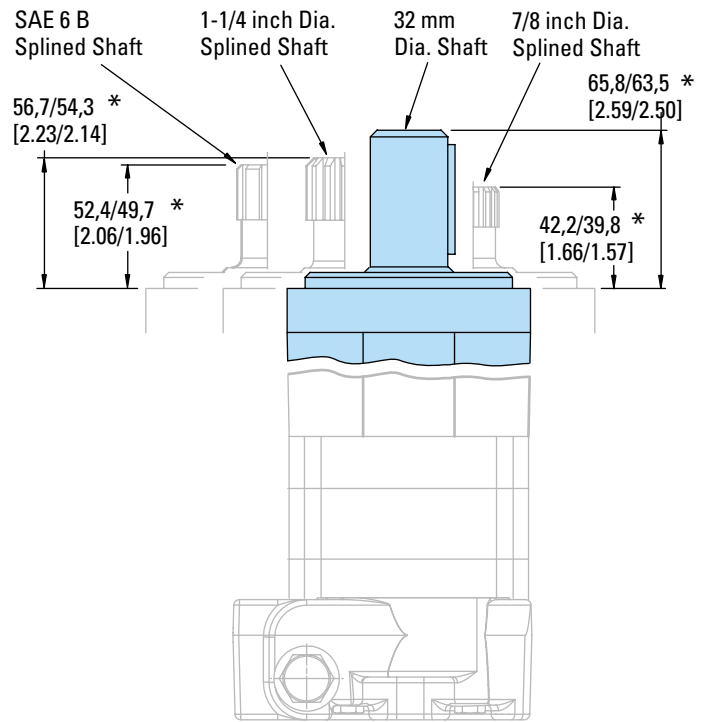
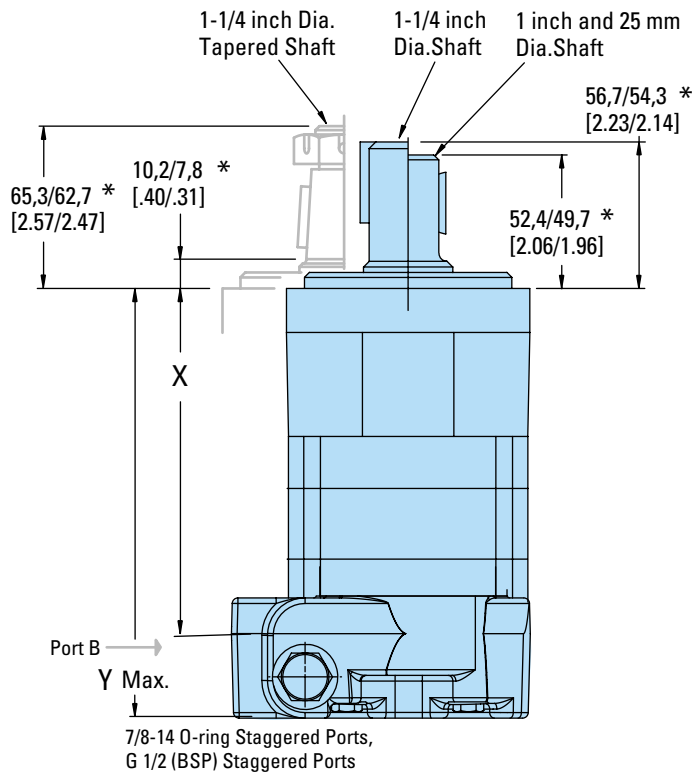

Standard Rotation  
Viewed from Shaft End  
Port A Pressurized — CW  
Port B Pressurized — CCW

\*Subtract 4,1/3,6 [1.16/1.14] when ordering motor with 4-bolt magneto flange

2000 Series Standard Motor  
with 7/8-14 O-Ring Staggered  
Ports or G1/2 (BSP)  
Staggered Ports

## DISPLACEMENT

| cm <sup>3</sup> /r [in <sup>3</sup> /r] | 80 [4.9]     | 100 [6.2]    | 130 [8.0]    | 160 [9.6]    | 195 [11.9]   | 245 [14.9]   | 305 [18.7]   | 395 [24.0]   | 490 [29.8]    |
|---|--------------|--------------|--------------|--------------|--------------|--------------|--------------|--------------|---------------|
| Dim. X mm [in]                          | 137,0 [5.40] | 141,6 [5.58] | 147,9 [5.83] | 147,9 [5.83] | 154,8 [6.10] | 163,7 [6.45] | 175,1 [6.90] | 191,1 [7.53] | 208,4 [8.21]  |
| Dim. Y mm [in]                          | 184,5 [7.26] | 189,0 [7.44] | 195,4 [7.69] | 195,4 [7.69] | 202,2 [7.96] | 211,1 [8.31] | 222,6 [8.76] | 238,6 [9.39] | 255,8 [10.07] |

# Wheel Mount Motors

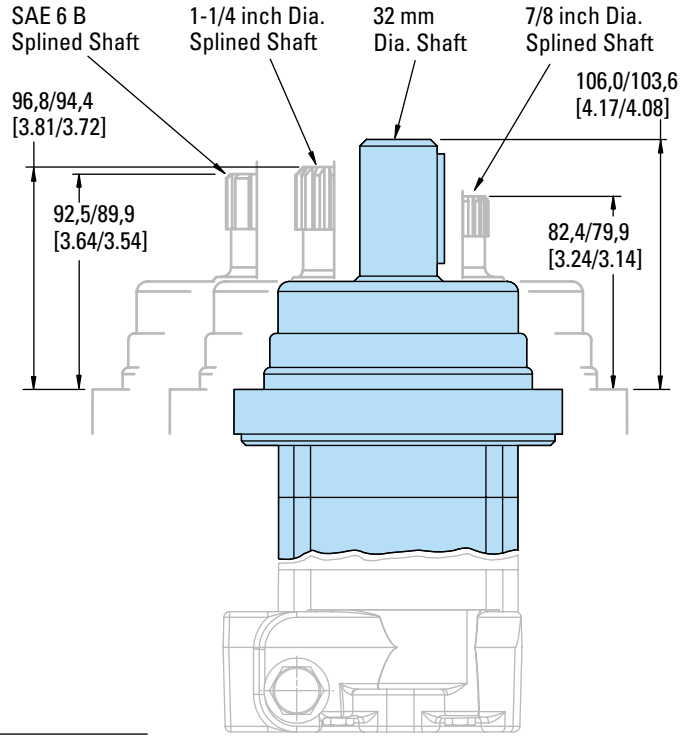
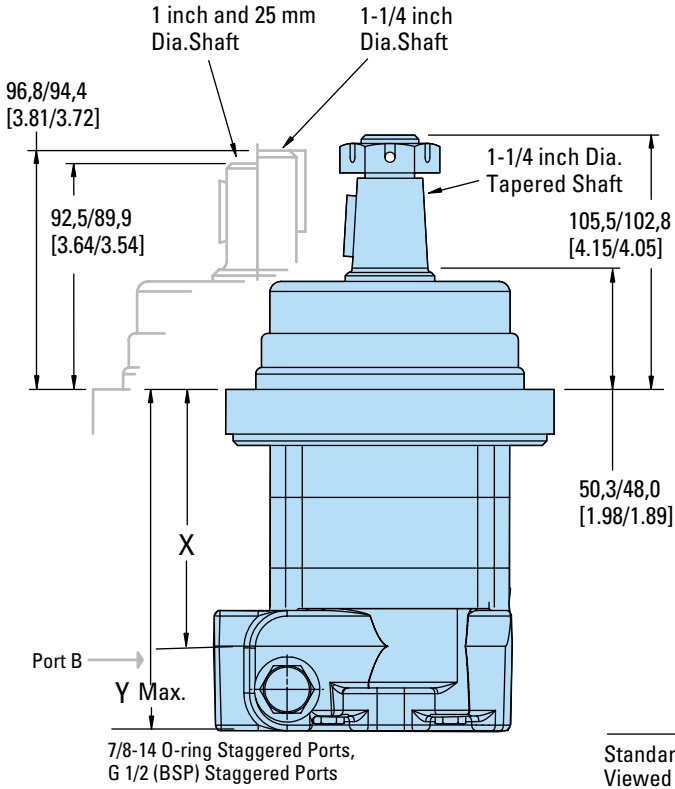

Standard Rotation  
Viewed from Shaft End  
Port A Pressurized — CW  
Port B Pressurized — CCW

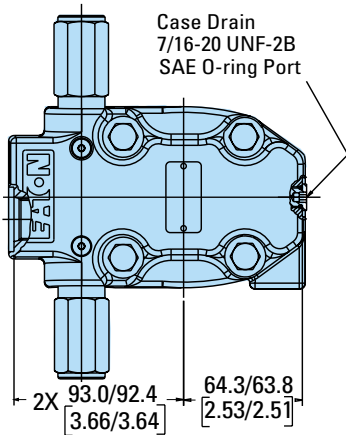

2000 Series Wheel Motor  
with 7/8-14 O-Ring Staggered  
Ports or G1/2 (BSP)  
Staggered Ports

## DISPLACEMENT

| cm <sup>3</sup> /r [in <sup>3</sup> /r] | 80 [4.9]     | 100 [6.2]    | 130 [8.0]    | 160 [9.6]    | 195 [11.9]   | 245 [14.9]   | 305 [18.7]   | 395 [24.0]   | 490 [29.8]   |
|---|--------------|--------------|--------------|--------------|--------------|--------------|--------------|--------------|--------------|
| Dim. X mm [in]                          | 96,9 [3.82]  | 101,4 [4.00] | 107,8 [4.25] | 107,8 [4.25] | 114,6 [4.52] | 123,5 [4.87] | 135,0 [5.32] | 151,0 [5.95] | 168,2 [6.63] |
| Dim. Y mm [in]                          | 144,3 [5.68] | 148,9 [5.86] | 155,2 [6.11] | 155,2 [6.11] | 162,1 [6.38] | 171,0 [6.73] | 182,4 [7.18] | 198,4 [7.81] | 215,7 [8.49] |

# Bearingless Motors

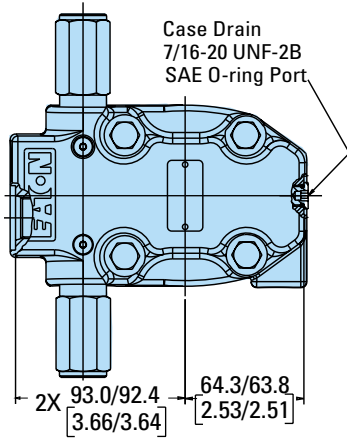
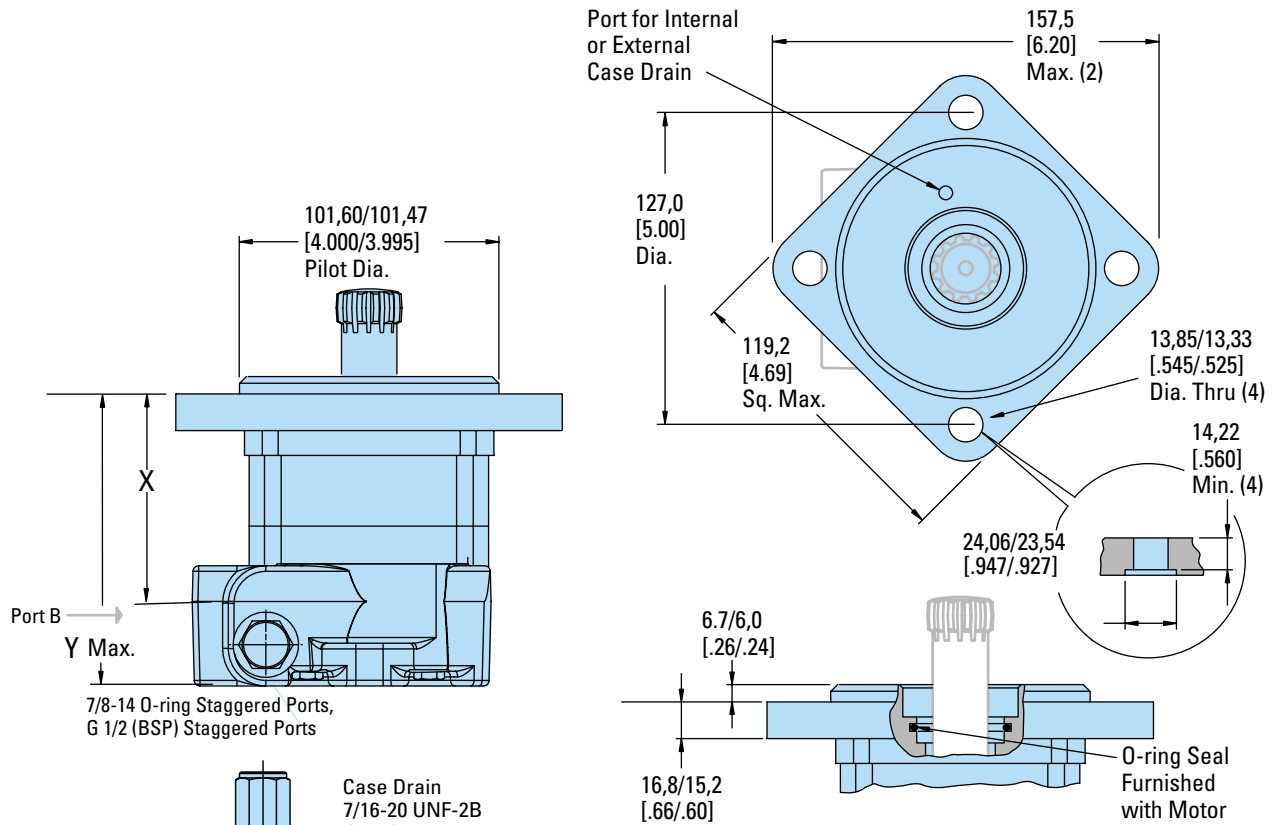

Standard Rotation  
Viewed from Drive End  
Port A Pressurized — CW  
Port B Pressurized — CCW

- C 35,86 [1.412] Dia.
- D 34,04 [1.340] Dia.
- E 81,0 [3.19] Min. Full Form Dia.
- F 86,1 [3.39] Max.
- G 62,10 [2.445] Full Form Dia.
- H 38,40 [1.512] Dia.
- J 43,7 [1.72] Dia.
- K 25,91 [1.020]
- L 8,25 [.325]
- M 0,89 [.035]
- N 15°

Mating Coupling Blank  
Eaton Part No. 13307-003

For 2000 Series Bearingless Motor application information contact your Eaton representative (mating coupling blanks available from Eaton Hydraulics). Note: After machining blank, part must be hardened per Eaton specification.

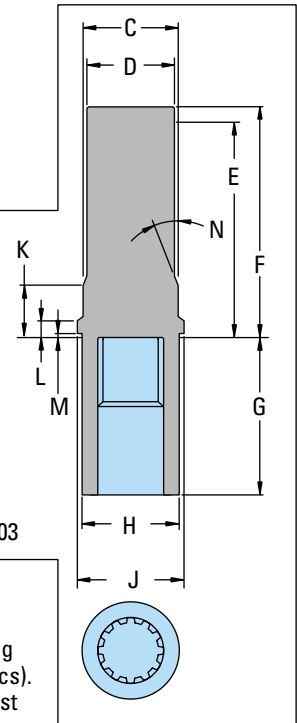

2000 Series Bearingless Motor with 7/8-14 O-Ring Staggered Ports or G1/2 (BSP) Staggered Ports

## DISPLACEMENT

| cm <sup>3</sup> /r [in <sup>3</sup> /r] | 80 [4.9]     | 100 [6.2]    | 130 [8.0]    | 160 [9.6]    | 195 [11.9]   | 245 [14.9]   | 305 [18.7]   | 395 [24.0]   | 490 [29.8]   |
|---|--------------|--------------|--------------|--------------|--------------|--------------|--------------|--------------|--------------|
| Dim. X mm [in]                          | 79,0 [3.11]  | 83,5 [3.29]  | 89,9 [3.54]  | 89,9 [3.54]  | 96,8 [3.81]  | 105,6 [4.16] | 117,1 [4.61] | 133,1 [5.24] | 150,3 [5.92] |
| Dim. Y mm [in]                          | 126,8 [4.99] | 131,4 [5.17] | 137,7 [5.42] | 137,7 [5.42] | 144,6 [5.69] | 153,5 [6.04] | 164,9 [6.49] | 180,9 [7.12] | 198,2 [7.80] |

# Model Code

## Model Code for 2000 Series Motors

The following 24-digit coding system has been developed to identify all of the configuration options for the 2000 Series motor

Use this model code to specify a motor with the desired features. All 24-digits of the code must be present when ordering.

You may want to photocopy the matrix below to ensure that each number is entered in the correct box.

### Sample Model Code:

#### Model Code — 2000 Series Disc Valve Motors

|   |   |   |   |   |   |   |   |   |    |    |    |    |    |    |    |    |    |    |    |    |    |    |    |
|---|---|---|---|---|---|---|---|---|----|----|----|----|----|----|----|----|----|----|----|----|----|----|----|
| 1 | 2 | 3 | 4 | 5 | 6 | 7 | 8 | 9 | 10 | 11 | 12 | 13 | 14 | 15 | 16 | 17 | 18 | 19 | 20 | 21 | 22 | 23 | 24 |
| M | 0 | 2 |   |   |   |   |   |   |    |    |    |    |    | 0  | 0  |    |    |    |    |    |    | 0  | 0  |

| Nos  | Feature  | Code | Description   | Nos  | Feature      | Code | Description   |
|------|--|------|---|------|--------------|------|---|
| 1    | Product Series                                       | M    | Motor   | 8, 9 | Output Shaft | 00   | Bearingless   |
| 2, 3 | 2000 Series  | 02   | 2000 Series   |      |              | 01   | 1 inch Dia. Straight with Woodruff Key, 1/4-20 Threaded Hole and 38,4 [1.51] Max. Coupling Length                               |
| 4, 5 | Displacement cm <sup>3</sup> /r [in <sup>3</sup> /r] |      |   |      |              | 02   | 1-1/4 inch Dia. Straight with Straight Key, 3/8-16 Threaded Hole and 47,3 [1.86] Max. Coupling Length                           |
|      |  | 05   | 80 [ 4.9]   |      |              | 23   | 32 mm dia. Straight with Straight Key, M8 x 1,25 -6H Threaded Hole and 56,4 [2.22] Max. Coupling Length                         |
|      |  | 06   | 100 [ 6.2]  |      |              | 04   | 1-1/4 inch Dia. Splined 14 T, 3/8-16 Threaded Hole and 33,0 [1.30] Min. Full Spline Length and 45,5 [1.79] Max. Coupling Length |
|      |  | 08   | 130 [ 8.0]  |      |              | 03   | 1-1/4 inch Dia. Tapered with Straight Key and Nut   |
|      |  | 10   | 160 [ 9.6]  |      |              | 05   | 1 inch SAE 6B Splined 6T, 1/4-20 Threaded Hole and 22,8 [.90] Min. Full Spline Length and 28,8 [1.13] Max. Coupling Length      |
|      |  | 12   | 195 [11.9]  |      |              | 07   | 7/8 inch Dia. Splined 13T, 15,2 [.60] Min. Full Spline Length and 30,8 [1.21] Max. Coupling Length                              |
|      |  | 15   | 245 [14.9]  |      |              | 24   | 1-1/4 inch Dia. Straight with Straight Key, 3/8-16 Threaded Hole and Corrosion Resistant (seal area to shaft end)               |
|      |  | 19   | 305 [18.7]  |      |              | 25   | 1-1/4 inch Dia. Tapered with Straight Key and Nut, Corrosion Resistant (under seal area only)                                   |
|      |  | 24   | 395 [24.0]  |      |              | 26   | 25 mm Dia. Straight with Straight Key, M8 x 1,25 -6H Threaded Hole and 38,4 [1.51] Max. Coupling Length                         |
|      |  | 30   | 490 [29.8]  |      |              |      |   |
| 6, 7 | Mounting Flange                                      |      |   |      |              |      |   |
|      |  | AD   | 4 Bolt (Bearingless) 101,6 [4.00] Pilot Dia. and 13,59 [.535] Dia. Mounting Holes on 127,0 [5.00] Dia. B.C.   |      |              |      |   |
|      |  | AC   | 2 Bolt SAE A (Std.) 82,5 [3.25] Pilot Dia. and 13,59 [.535] Dia. Mtg. Holes on 106,4 [4.19] Dia. B.C.   |      |              |      |   |
|      |  | AB   | 4 Bolt (Wheel) 108,0 [4.25] Pilot Dia. and 13,59 [.535] Dia. Mounting Holes on 147,6 [5.81] Dia. B.C.   |      |              |      |   |
|      |  | AH   | 4 Bolt (Standard) 82,5 [3.25] Pilot Dia. and 14,59 [.535] Dia. Mounting Holes on 106,4 [4.19] Dia. B.C.   |      |              |      |   |
|      |  | AJ   | 4 Bolt Magneto (Std.) 82,5 [3.25] Pilot Dia. and 13,59 [.535] Dia. Mtg. Holes on 106,4 [4.19] Dia. B.C.   |      |              |      |   |
|      |  | AF   | 2 Bolt SAE B (Std.) 101,6 [4.00] Pilot Dia. and 14,35 [.565] Dia. Mtg. Holes on 146,0 [5.75] Dia. B.C.  |      |              |      |   |
|      |  | AP   | 4 Bolt (wheel compatible for HAYES BRAKE) 107,9 [4.25] Pilot Dia. and 13,59 [.535] Dia. Mounting Holes on 147,6 [5.81] Dia. B.C. with Turned Down Housing to 88,9 [3.50] Dia. |      |              |      |   |

# Model Code

Sample Model Code:

## Model Code — 2000 Series Disc Valve Motors

|   |   |   |   |   |   |   |   |   |    |    |    |    |    |    |    |    |    |    |    |    |    |    |    |
|---|---|---|---|---|---|---|---|---|----|----|----|----|----|----|----|----|----|----|----|----|----|----|----|
| 1 | 2 | 3 | 4 | 5 | 6 | 7 | 8 | 9 | 10 | 11 | 12 | 13 | 14 | 15 | 16 | 17 | 18 | 19 | 20 | 21 | 22 | 23 | 24 |
| M | 0 | 2 |   |   |   |   |   |   |    |    |    |    |    | 0  | 0  |    |    |    |    |    |    | 0  | 0  |

| Nos    | Feature  | Code | Description  | Nos    | Feature                             | Code | Description  |
|--------|--|------|--|--------|-------------------------------------|------|--|
| 10, 11 | Port Type  | AA   | 7/8-14 UNF –2B SAE O-ring (Staggered)                            | 19, 20 | Special Features (Hardware)         | 00   | None   |
|        |  | AG   | G 1/2 BSP Straight Thread ports (Staggered)                      |        |                                     | 01   | Viton Seals  |
|        |  | AB   | Manifold Mount with 3/8-16 UNC Mounting Threads (3)              |        |                                     | 10   | Viton Shaft Seal   |
|        |  | AE   | Manifold Mount with M10 x 1,5 -6H Mounting Threads (3)           |        |                                     | 57   | 105 bar [1500 psi] Internal Cross Over Relief Valve (staggered 7/8" o-ring ports only) |
|        |  | AD   | 7/8-14 UNF –2B SAE O-ring (End Ports)                            |        |                                     | 58   | 120 bar [1750 psi] Internal Cross Over Relief Valve (staggered 7/8" o-ring ports only) |
|        |  | AF   | 1–1/16 - 12 UN-2B O-ring ports (Positioned 180° Apart)           |        |                                     | 59   | 140 bar [2000 psi] Internal Cross Over Relief Valve (staggered 7/8" o-ring ports only) |
| 12, 13 | Case Flow<br>(Shuttles available with port code AA or AD only)   | 01   | 7/16-20 UNF –2B SAE O-ring (Case Drain)                          |        |                                     | 60   | 155 bar [2250 psi] Internal Cross Over Relief Valve (staggered 7/8" o-ring ports only) |
|        |  | 02   | G 1/4 (BSP) straight thread port (Case Drain)                    |        |                                     | 61   | 170 bar [2500 psi] Internal Cross Over Relief Valve (staggered 7/8" o-ring ports only) |
|        |  | 04   | Shuttle Valve with 7/16-20 UNF –2B SAE O-ring (Case Drain)       |        |                                     | 62   | 190 bar [2750 psi] Internal Cross Over Relief Valve (staggered 7/8" o-ring ports only) |
|        |  | 05   | Shuttle Valve with G 1/4 (BSP) straight thread port (Case Drain) |        |                                     | 63   | 205 bar [3000 psi] Internal Cross Over Relief Valve (staggered 7/8" o-ring ports only) |
| 14     | Low Pressure Relief<br>(LPR available with a combination of case flow code 04 or 05 and port code AA or AD only) | 0    | None   | 21     | Special Features (Assembly)         | 0    | None   |
|        |  | A    | Set @ 4,5 bar [65 psi]∞  |        |                                     | A    | Flange Rotated 90°   |
|        |  | B    | Set @ 15,2 bar [220 psi]∞  |        |                                     | B    | Reverse Rotation   |
|        |  | C    | Set @ 20,7 bar [300 psi]∞  |        |                                     |      |  |
| 15, 16 | Valve Option   | 00   | None   | 22     | Paint/Special Packaging             | 0    | No Paint   |
| 17, 18 | Accessories  | 00   | None   |        |                                     | A    | Painted Low Gloss Black  |
|        |  | AA   | Seal Guard   |        |                                     | B    | Corrosion Protected  |
|        |  | AB   | Speed Sensor (Std. With Weatherpack shroud connector)            | 23     | Eaton Assigned Code when Applicable | 0    | Assigned Code  |
|        |  | AH   | Speed Sensor (Std. With M12 connector)                           |        |                                     | 24   | Eaton Assigned Design Code   |
|        |  | AL   | Quadrature Speed Sensor Version 2 with M12                       |        |                                     | 0    | Assigned Design Code   |

**Eaton**  
14615 Lone Oak Road  
Eden Prairie, MN 55344  
USA  
Tel: 952 937-9800  
Fax: 952 974-7722  
[www.hydraulics.eaton.com](http://www.hydraulics.eaton.com)

**Eaton**  
20 Rosamond Road  
Footscray  
Victoria 3011  
Australia  
Tel: (61) 3 9319 8222  
Fax: (61) 3 9318 5714

**Eaton**  
Eaton Fluid Power GmbH  
Dr.-Reckeweg-Str. 1  
D-76532 Baden-Baden, Germany  
Tel: +49 (0) 7221 682-0  
Fax: +49 (0) 7221 682-788

**Char-Lynn®**



**Char-Lynn**

© 2003 Eaton Corporation  
All Rights Reserved  
Printed in USA  
Document No. C-MOLO-TM001-E  
September 2003