

# QD8 Quik-Drive Tap-Changer Motor Replacement Kit 57A63675100A Installation Instructions



## **DISCLAIMER OF WARRANTIES AND LIMITATION OF LIABILITY**

The information, recommendations, descriptions and safety notations in this document are based on Eaton Corporation's ("Eaton") experience and judgment and may not cover all contingencies. If further information is required, an Eaton sales office should be consulted. Sale of the product shown in this literature is subject to the terms and conditions outlined in appropriate Eaton selling policies or other contractual agreement between Eaton and the purchaser.

THERE ARE NO UNDERSTANDINGS, AGREEMENTS, WARRANTIES, EXPRESSED OR IMPLIED, INCLUDING WARRANTIES OF FITNESS FOR A PARTICULAR PURPOSE OR MERCHANTABILITY, OTHER THAN THOSE SPECIFICALLY SET OUT IN ANY EXISTING CONTRACT BETWEEN THE PARTIES. ANY SUCH CONTRACT STATES THE ENTIRE OBLIGATION OF EATON. THE CONTENTS OF THIS DOCUMENT SHALL NOT BECOME PART OF OR MODIFY ANY CONTRACT BETWEEN THE PARTIES.

In no event will Eaton be responsible to the purchaser or user in contract, in tort (including negligence), strict liability or otherwise for any special, indirect, incidental or consequential damage or loss whatsoever, including but not limited to damage or loss of use of equipment, plant or power system, cost of capital, loss of power, additional expenses in the use of existing power facilities, or claims against the purchaser or user by its customers resulting from the use of the information, recommendations and descriptions contained herein. The information contained in this manual is subject to change without notice.

## Contents

<b>DISCLAIMER OF WARRANTIES AND LIMITATION OF LIABILITY</b> .....	<b>II</b>
<b>SAFETY FOR LIFE</b> .....	<b>IV</b>
<b>SAFETY INFORMATION</b> .....	<b>IV</b>
Safety instructions .....	iv
<b>PRODUCT INFORMATION</b> .....	<b>1</b>
Introduction .....	1
Read this manual first .....	1
Acceptance and initial inspection .....	1
Handling and storage .....	1
Quality standards .....	1
Additional information .....	1
Parts supplied .....	1
Tools required .....	1
<b>REMOVAL AND DISASSEMBLY PROCEDURE</b> .....	<b>2</b>
<b>REASSEMBLY AND INSTALLATION PROCEDURE</b> .....	<b>4</b>
<b>PLACING TAP-CHANGER INTO NEUTRAL</b> .....	<b>7</b>



## Safety for life



Eaton meets or exceeds all applicable industry standards relating to product safety in its Cooper Power™ series products. We actively promote safe practices in the use and maintenance of our products through our service literature, instructional training programs, and the continuous efforts of all Eaton employees involved in product design, manufacture, marketing, and service.

We strongly urge that you always follow all locally approved safety procedures and safety instructions when working around high voltage lines and equipment, and support our “Safety For Life” mission.

## Safety information

The instructions in this manual are not intended as a substitute for proper training or adequate experience in the safe operation of the equipment described. Only competent technicians who are familiar with this equipment should install, operate, and service it.

A competent technician has these qualifications:

- Is thoroughly familiar with these instructions.
- Is trained in industry-accepted high and low-voltage safe operating practices and procedures.
- Is trained and authorized to energize, de-energize, clear, and ground power distribution equipment.
- Is trained in the care and use of protective equipment such as arc flash clothing, safety glasses, face shield, hard hat, rubber gloves, clampstick, hotstick, etc.

Following is important safety information. For safe installation and operation of this equipment, be sure to read and understand all cautions and warnings.

### Hazard Statement Definitions

This manual may contain four types of hazard statements:

---

#### DANGER

Indicates an imminently hazardous situation which, if not avoided, will result in death or serious injury.

---

#### WARNING

Indicates a potentially hazardous situation which, if not avoided, could result in death or serious injury.

---

#### CAUTION

Indicates a potentially hazardous situation which, if not avoided, may result in minor or moderate injury.

---

#### CAUTION

Indicates a potentially hazardous situation which, if not avoided, may result in equipment damage only.

---

### Safety instructions

Following are general caution and warning statements that apply to this equipment. Additional statements, related to specific tasks and procedures, are located throughout the manual.

---

#### DANGER

**Hazardous voltage. Contact with hazardous voltage will cause death or severe personal injury. Follow all locally approved safety procedures when working around high- and low-voltage lines and equipment.**

G103.3

---

#### WARNING

**Before installing, operating, maintaining, or testing this equipment, carefully read and understand the contents of this manual. Improper operation, handling or maintenance can result in death, severe personal injury, and equipment damage.**

G101.0

---

#### WARNING

**This equipment is not intended to protect human life. Follow all locally approved procedures and safety practices when installing or operating this equipment. Failure to comply can result in death, severe personal injury and equipment damage.**

G102.1

---

#### WARNING

**Power distribution and transmission equipment must be properly selected for the intended application. It must be installed and serviced by competent personnel who have been trained and understand proper safety procedures. These instructions are written for such personnel and are not a substitute for adequate training and experience in safety procedures. Failure to properly select, install or maintain power distribution and transmission equipment can result in death, severe personal injury, and equipment damage.**

G122.2

## Product information

### Introduction

Eaton's Cooper Power™ series QD8 Quik-Drive tap-changer motor replacement kit includes instructions for replacing the motor on the polymer model of the QD8 Quik-Drive tap-changer.

### Read this manual first

Read and understand the contents of this manual and follow all locally approved procedures and safety practices before installing or operating this equipment.

### Acceptance and initial inspection

Each kit is in good condition when accepted by the carrier for shipment. Upon receipt, inspect the shipping container for signs of damage. Unpack the kit and inspect it thoroughly for damage incurred during shipment. If damaged is discovered, file a claim with the carrier immediately.

### Handling and storage

Be careful during handling and storage of the kit to minimize the possibility of damage. If the kit is to be stored for any length of time prior to installation, provide a clean, dry storage area.

### Quality standards

ISO 9001 Certified Quality Management System

### Additional information

These instructions cannot cover all details or variations in the equipment, procedures, or process described nor provide directions for meeting every possible contingency during installation, operation, or maintenance. For additional information, contact your representative.

### Parts supplied

Table 1. Tap-Changer Motor Replacement Kit			
Item	Part Number	Description	Qty
1	2242190B01	Motor	1
2	TAA114651003	Ring Terminal	3
3	0800011079Z	Wire Tie	3
4	2240787B34	Sprocket, 12-tooth (black)	1
5	2291647A34	Woodruff Key	1
6	0800073173Z	Retaining Ring	2
7	0800073190Z	Machine Screw, 8-32X0.5	4
8	2240787B44	Sprocket, 11-tooth (silver)	1

### Tools required

- 3/8 inch drive ratchet wrench
- 3/8 inch drive ratchet extension
- 1/4 inch socket
- 3/8 inch socket
- 7/16 inch socket
- 9/16 inch ratcheting box end wrench
- Phillips head screwdriver #2
- Standard blade screwdriver
- Diagonal cutters
- External snap ring pliers
- Torque wrench for in-lbs
- Crimping tool
- Pliers



Figure 1. Tap-changer motor replacement kit

## Removal and disassembly procedure

1. This procedure may be completed without removal of the tap changer from the voltage regulator. Carefully follow the procedures for partially untanking a voltage regulator in the document MN225008EN, VR-32 voltage regulator with Quik-Drive tap-changer installation, operation, and maintenance instructions.
2. It is recommended to start this procedure with the tap changer in the neutral position. See the section **Placing Tap-Changer into Neutral** located after the installation procedure.
3. Use diagonal cutters to cut the wire ties from the motor wires. Refer to Figure 2.

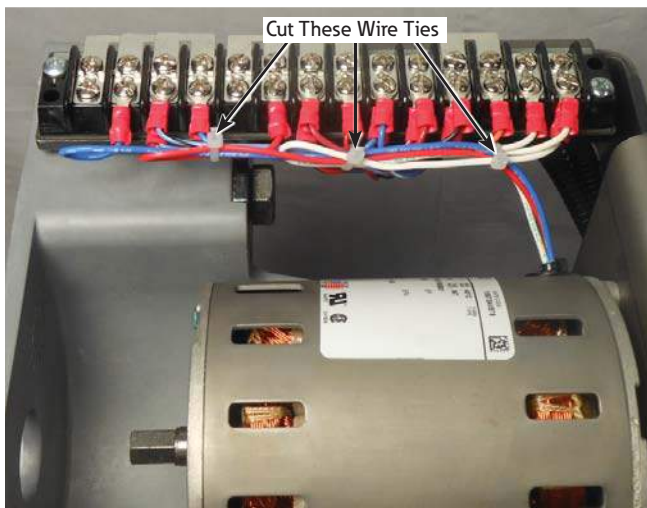

Figure 2. Removal of wire ties

4. Use a Phillips screwdriver to disconnect the white motor wire located on terminal "G," the red motor wire located on terminal #6 and the blue motor wire located on terminal #2. Refer to Figure 3.

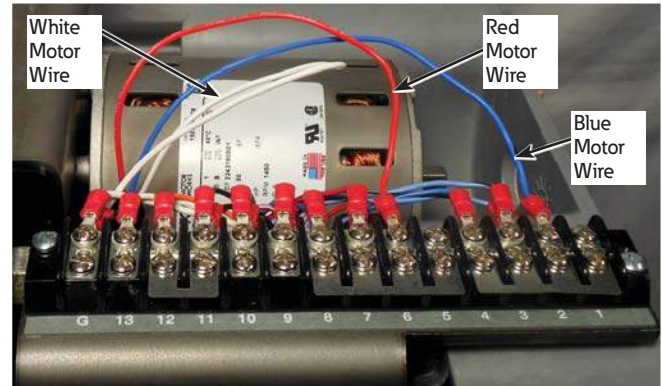

Figure 3. Disconnection of wires

5. Loosen the locknut on the chain tension screw with a 7/16" wrench. Loosen the chain tension screw with a screwdriver until the rubber bumper is against the motor mounting bracket. Refer to Figure 4.

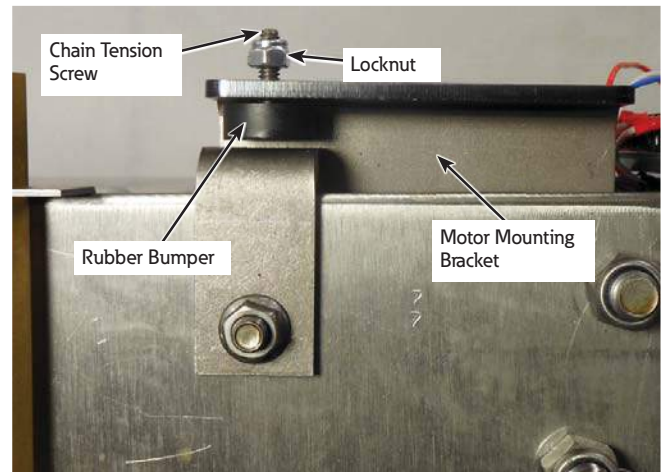

Figure 4. Loosening the chain tension

6. Remove the motor pivot stud locknut with a 9/16" ratcheting wrench. Pull the motor off of the motor pivot stud; make sure the Belleville washer stays on the motor pivot stud and does not fall into the tank. Set the motor in the motor relief area of the molded back panel. Refer to Figure 5 and Figure 6.



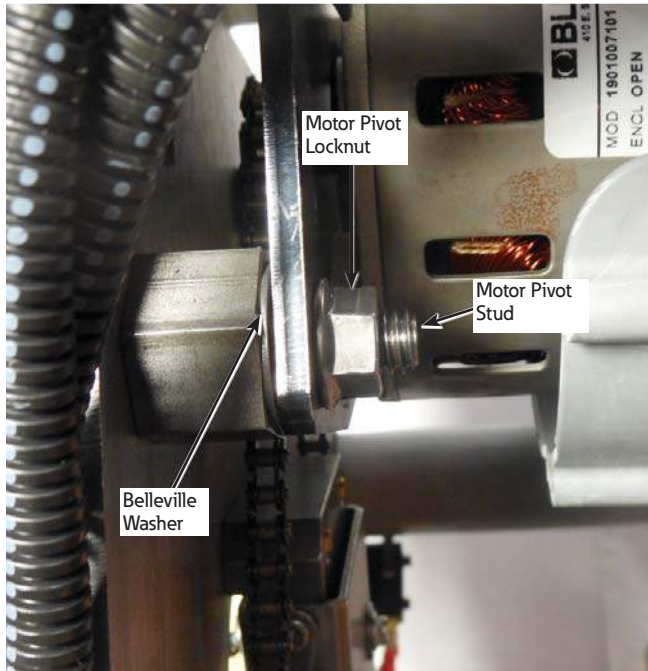

Figure 5. Motor pivot stud

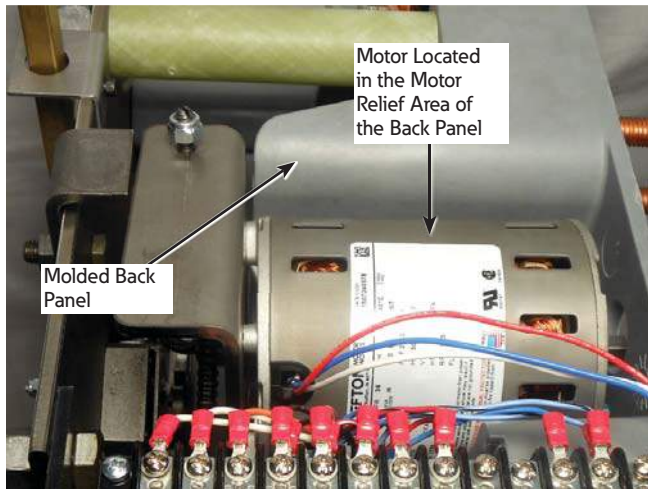

Figure 6. Removal of the motor

7. Remove the chain from the motor sprocket and set it on the brake assembly as shown in Figure 7. Lift the motor out of the relief area.

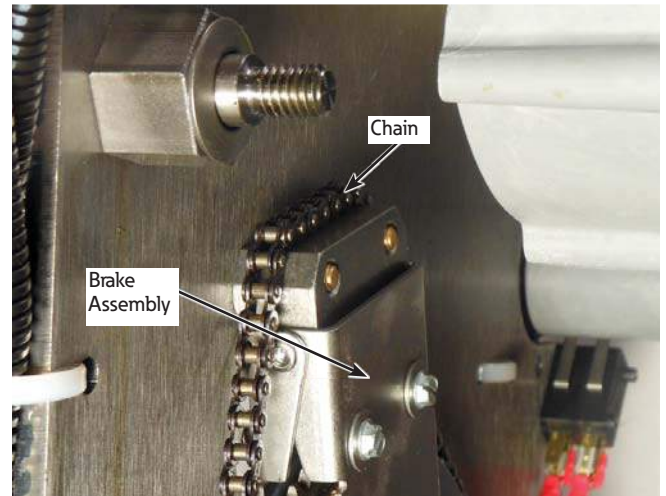

Figure 7. Removal of the chain

8. Remove the four screws securing the motor to the motor mounting plate using a 1/4" socket on a ratchet. Remove the motor mounting plate from the old motor. Refer to Figure 8.

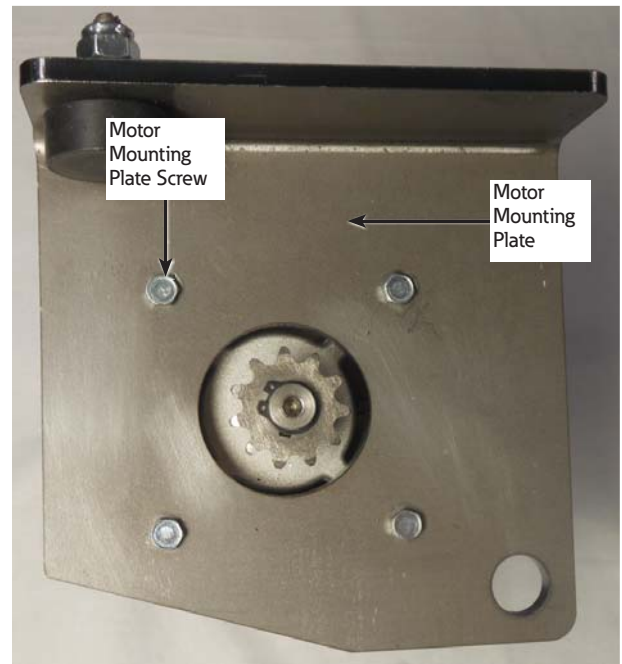

Figure 8. Removal of the motor plate

### Reassembly and installation procedure

9. The new motor kit has a 12-tooth sprocket (black) for the phenolic QD8 tap-changer and an 11-tooth sprocket (silver) for the polymer QD8 tap-changer. The motor shaft has two snap ring grooves and a Woodruff keyway. Install a snap ring with a snap ring pliers into the inner snap ring groove behind the Woodruff keyway. Using a pliers, squeeze the Woodruff key into the keyway with the Woodruff key tilted slightly down towards the end of the motor shaft. Refer to Figure 9.

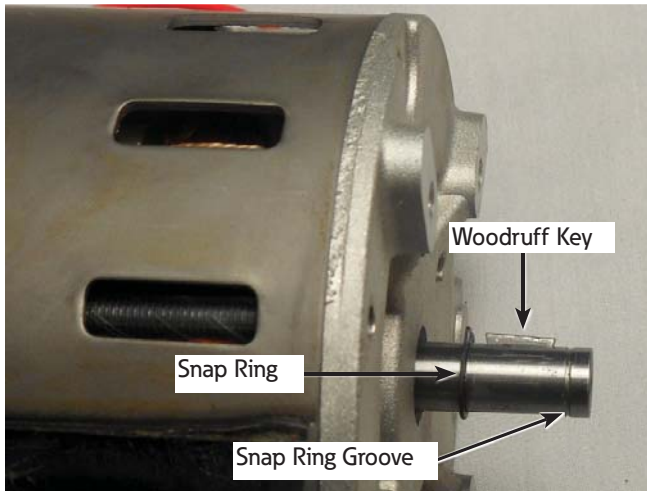

Figure 9. Woodruff key placement

10. Align the sprocket keyway with the Woodruff key on the motor shaft. Slide the sprocket onto the motor shaft with the sprocket hub end towards the motor. Install the second snap ring into the outer snap ring groove using a snap ring pliers. Refer to Figure 10.

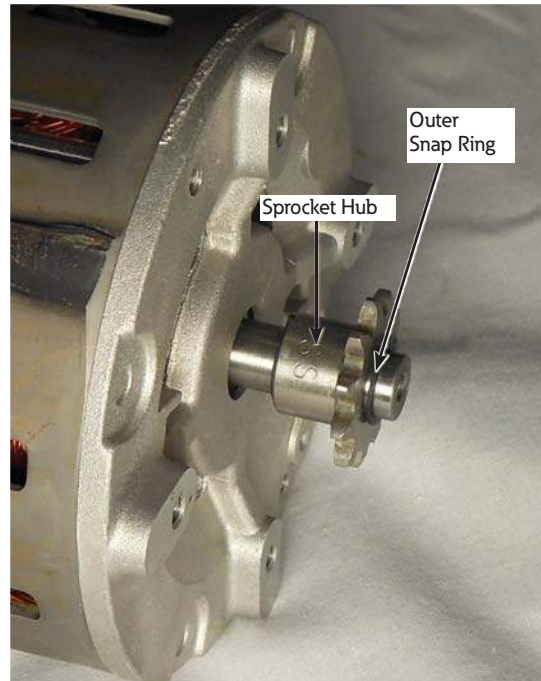

Figure 10. Placement of the sprocket

11. Use a 1/4" socket on a ratchet attach the motor mounting plate to the new motor using the new motor mounting plate screws provided in the motor replacement kit. Do not fully tighten. Make sure the motor wires are extending out of the top right of the motor when looking at the motor from the sprocket end. Refer to Figure 11. Using a torque wrench, tighten the motor plate mounting screws to 18–20 in-lbs (2.0–2.2 Nm).

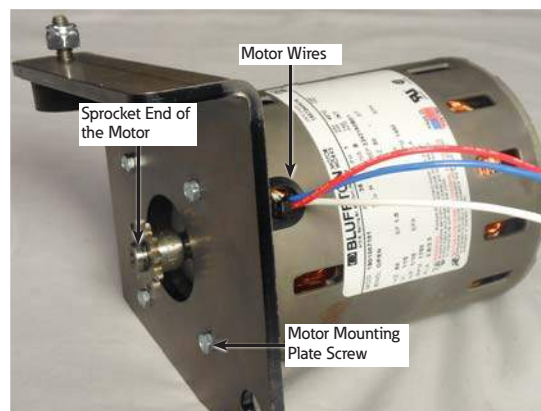

Figure 11. Motor mounting plate



12. Place the motor into the motor relief area of the molded back panel. Pull the chain under the drive sprocket gear insuring that the chain fully engages the sprocket teeth. Pull the chain up and onto the motor sprocket teeth. If there are any loose links around the bottom of the drive sprocket gear, the motor will not fit properly. Refer to Figure 12.

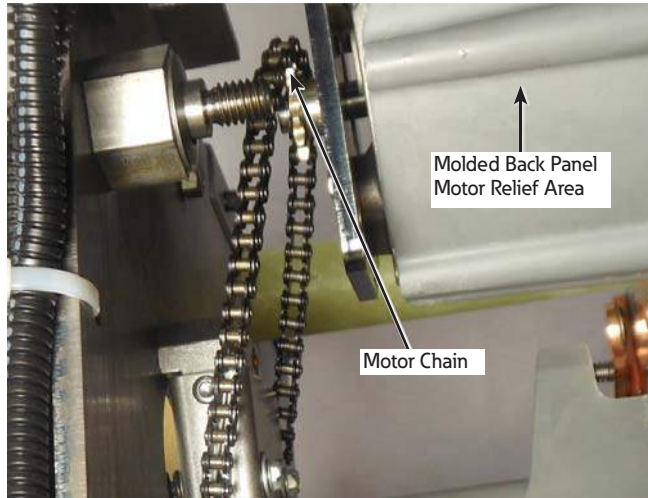

Figure 12. Locating motor

13. Insure that the Belleville washer is installed over the motor-mount stud with the cupped side facing in. See Figure 13.

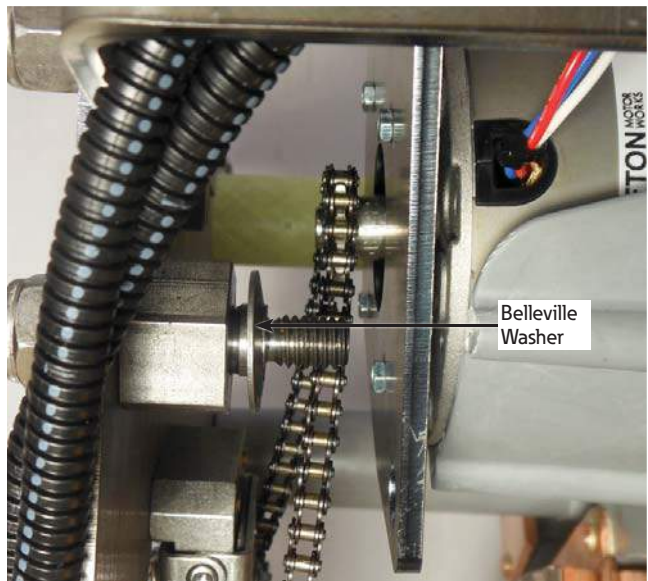

Figure 13. Belleville washer on the motor mounting stud

---

## IMPORTANT

---

Make sure that the mounting hole in the motor mounting bracket is fully seated on the shoulder of the mounting stud. If it is not fully seated, the chain may bind and fall off. See Figure 14 and Figure 15.

---

14. Move the motor assembly into position with the motor chain adjustment screw bumper located on top of the adjustment bracket and the motor pivot stud inserted through the mounting hole in the motor mounting plate. Secure the motor mounting plate to the motor pivot stud with the locknut removed in Step 6. Refer to Figure 14 and Figure 15. Tighten the nut snugly, but not tightly.

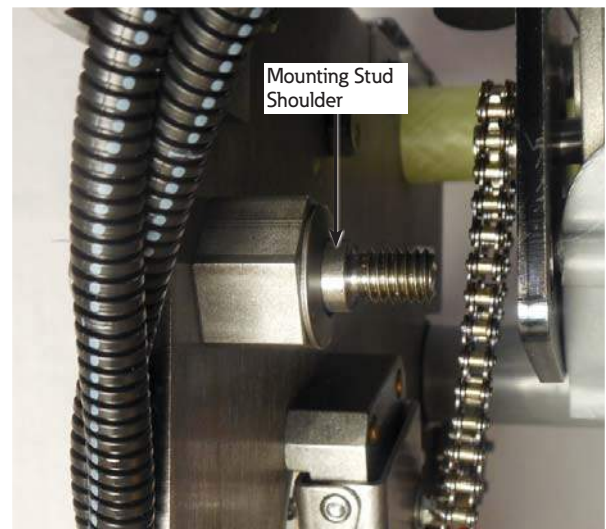

Figure 14. Belleville washer on the motor mounting stud

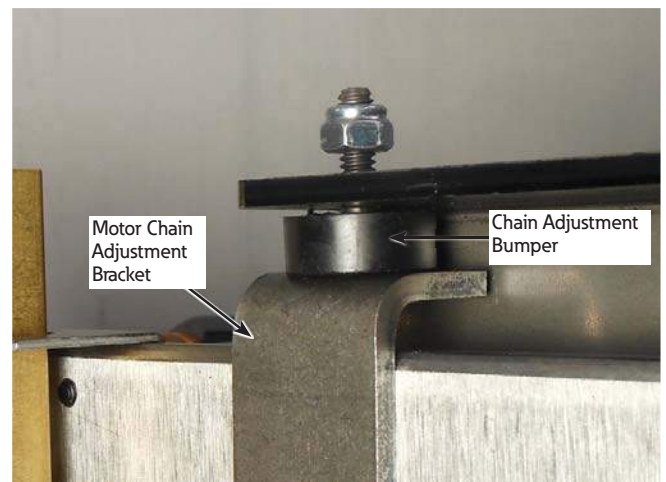
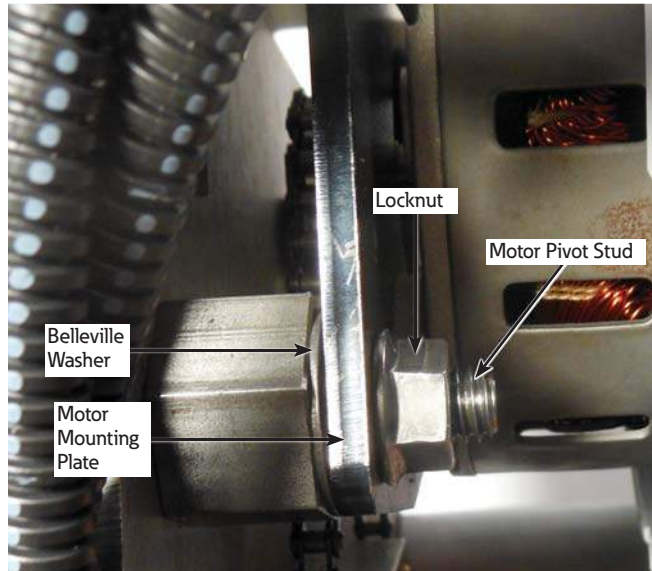

Figure 15. Motor positioning

## QD8 Quik-Drive Tap-Changer Motor Replacement Kit 57A63675100A



**Figure 16. Motor mounting plate properly seated on the mounting stud shoulder. Notice that there is no gap between the motor mounting plate and Belleville washer.**

15. Adjust the chain tension by turning the motor bumper screw with a blade screw driver. Adjust the motor mount bumper screw until 1/4" deflection exists when exerting pressure on the chain. Secure the motor mount bumper screw in place with the locknut using a 7/16" wrench. Refer to Figure 17.

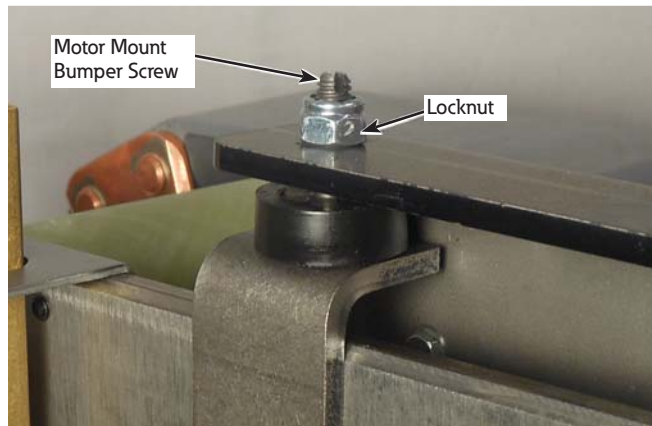

**Figure 17. Chain tension**

16. Using a torque wrench tighten the pivot motor stud locknut to 180–192 in-lbs (20.0–21.1 Nm). See Figure 16.
17. Trim the motor wires with a diagonal cutter to a length of 8 inches. Crimp one of the supplied ring tongue connectors to the end of each wire.

18. Attach the terminals to the motor connection points on the terminal board as follows:

- White wire connects to terminal G
- Red wire connects to terminal #6
- Blue wire connects to terminal #2

Refer to Figure 18.

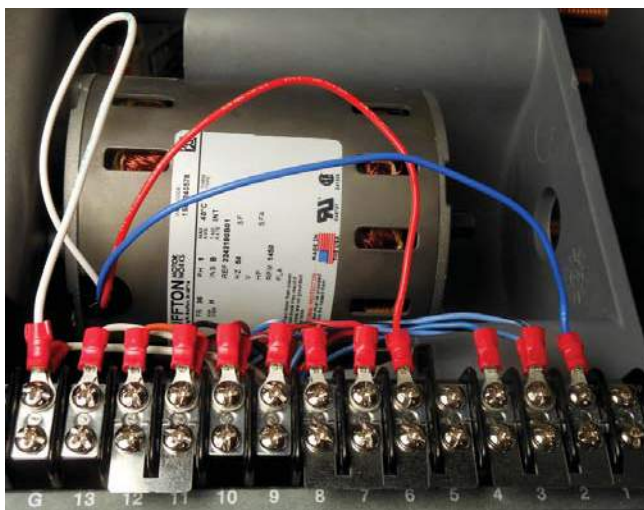

**Figure 18. Wiring connections**

19. Use the wire ties provided in the motor replacement kit to bundle all the wires near the terminal board. Trim the excess length of the wire ties. Refer to Figure 19.



**Figure 19. Wire fastening**

20. Ensure that the tap-changer is in the neutral position when the work is completed.



### Placing tap-changer into neutral

1. Place a 3/8" socket with extension and ratchet on the output shaft of the motor; rotate the motor until the contacts and other components are aligned in the neutral position. See Figure 20.

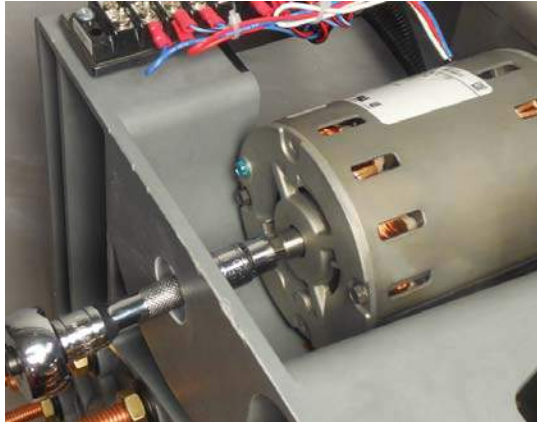

**Figure 20. Rotating the motor shaft**

2. Confirm that the regulator is in the neutral position:
  - A. Main movable contacts are located on the neutral stationary contact, which is located at the 11 o'clock position. See Figure 21.

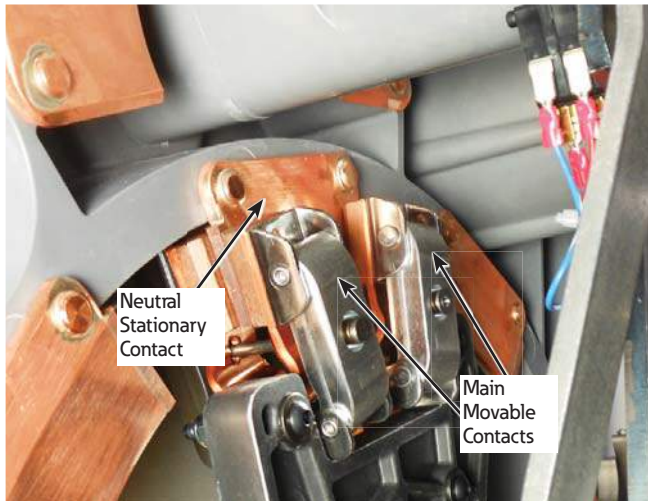

**Figure 21. Neutral stationary contact position for main movable contacts**

- B. The reversing movable contact is located on the reversing neutral stationary contact. See Figure 22.

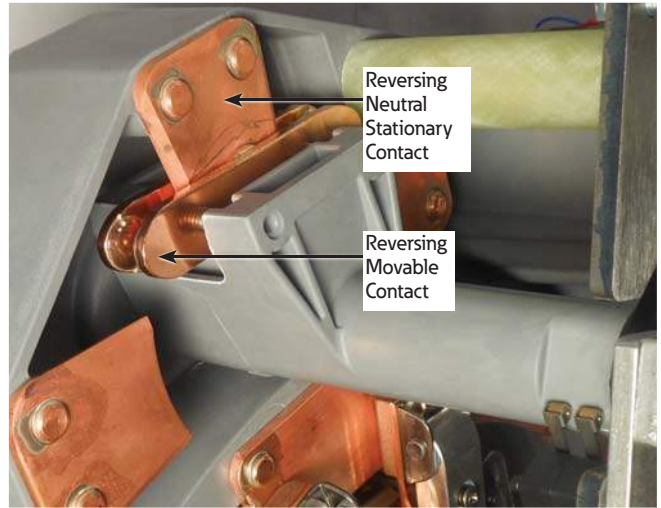

**Figure 22. Neutral position for reversing movable**

- C. The pinion cam is pointing to the right over the holding switch actuator. See Figure 23.

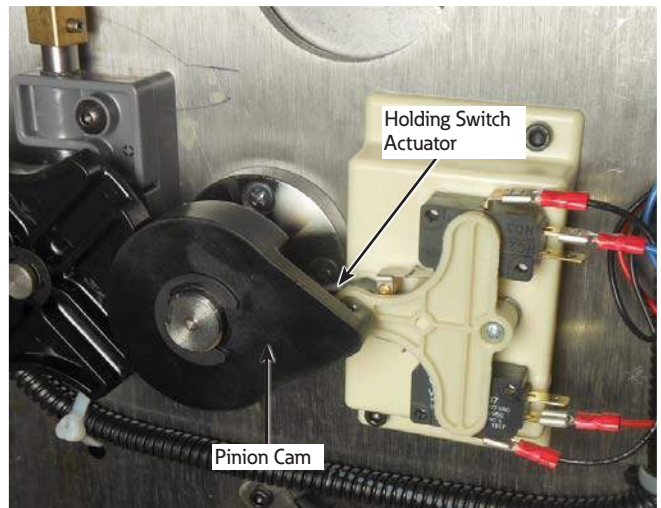

**Figure 23. Neutral position for position indicator pinion cam and holding switch**

D. The neutral switch will be depressed with the switch lever. See Figure 24.

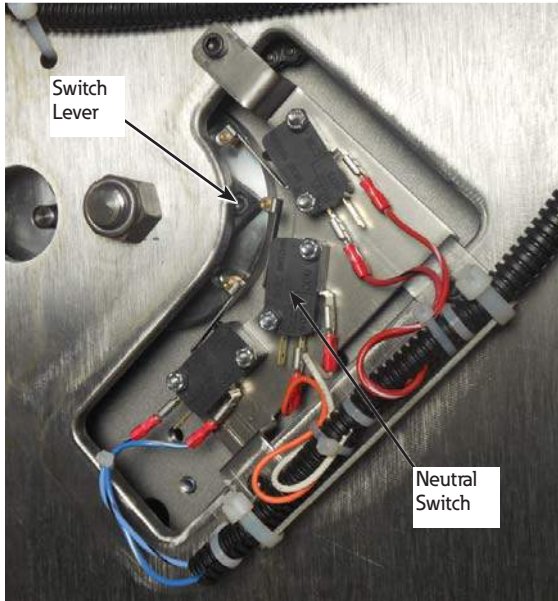

Figure 24. Neutral switch is depressed



**Eaton**  
1000 Eaton Boulevard  
Cleveland, OH 44122  
United States  
Eaton.com

**Eaton's Power Systems Division**  
2300 Badger Drive  
Waukesha, WI 53188  
United States  
Eaton.com/cooperpowerseries

© 2016 Eaton  
All Rights Reserved  
Printed in USA  
Publication No. MN225038EN  
June 2016  
57A63675100A Rev 06

Eaton is a registered trademark.

All trademarks are property  
of their respective owners.

For Eaton's Cooper Power series product  
information  
call 1-877-277-4636 or visit:  
[www.eaton.com/cooperpowerseries](http://www.eaton.com/cooperpowerseries).