

## QD8 Quik-Drive tap-changer micro-switch replacement kit 5740794B05 installation instructions



## **DISCLAIMER OF WARRANTIES AND LIMITATION OF LIABILITY**

The information, recommendations, descriptions and safety notations in this document are based on Eaton Corporation's ("Eaton") experience and judgment and may not cover all contingencies. If further information is required, an Eaton sales office should be consulted. Sale of the product shown in this literature is subject to the terms and conditions outlined in appropriate Eaton selling policies or other contractual agreement between Eaton and the purchaser.

THERE ARE NO UNDERSTANDINGS, AGREEMENTS, WARRANTIES, EXPRESSED OR IMPLIED, INCLUDING WARRANTIES OF FITNESS FOR A PARTICULAR PURPOSE OR MERCHANTABILITY, OTHER THAN THOSE SPECIFICALLY SET OUT IN ANY EXISTING CONTRACT BETWEEN THE PARTIES. ANY SUCH CONTRACT STATES THE ENTIRE OBLIGATION OF EATON. THE CONTENTS OF THIS DOCUMENT SHALL NOT BECOME PART OF OR MODIFY ANY CONTRACT BETWEEN THE PARTIES.

In no event will Eaton be responsible to the purchaser or user in contract, in tort (including negligence), strict liability or otherwise for any special, indirect, incidental or consequential damage or loss whatsoever, including but not limited to damage or loss of use of equipment, plant or power system, cost of capital, loss of power, additional expenses in the use of existing power facilities, or claims against the purchaser or user by its customers resulting from the use of the information, recommendations and descriptions contained herein. The information contained in this manual is subject to change without notice.

## Contents

<b>DISCLAIMER OF WARRANTIES AND LIMITATION OF LIABILITY</b> .....	<b>II</b>
<b>SAFETY FOR LIFE</b> .....	<b>IV</b>
<b>SAFETY INFORMATION</b> .....	<b>IV</b>
Safety instructions .....	iv
<b>PRODUCT INFORMATION</b> .....	<b>1</b>
Introduction .....	1
Read this manual first .....	1
Acceptance and initial inspection .....	1
Handling and storage .....	1
Quality standards .....	1
Additional information .....	1
Tools required .....	1
<b>INSTALLATION PROCEDURE</b> .....	<b>2</b>
Neutral and safety switches .....	2
Logic switches .....	3
<b>PLACING TAP-CHANGER INTO NEUTRAL</b> .....	<b>4</b>



## Safety for life



Eaton meets or exceeds all applicable industry standards relating to product safety in its Cooper Power™ series products. We actively promote safe practices in the use and maintenance of our products through our service literature, instructional training programs, and the continuous efforts of all Eaton employees involved in product design, manufacture, marketing, and service.

We strongly urge that you always follow all locally approved safety procedures and safety instructions when working around high voltage lines and equipment, and support our “Safety For Life” mission.

## Safety information

The instructions in this manual are not intended as a substitute for proper training or adequate experience in the safe operation of the equipment described. Only competent technicians who are familiar with this equipment should install, operate, and service it.

A competent technician has these qualifications:

- Is thoroughly familiar with these instructions.
- Is trained in industry-accepted high and low-voltage safe operating practices and procedures.
- Is trained and authorized to energize, de-energize, clear, and ground power distribution equipment.
- Is trained in the care and use of protective equipment such as arc flash clothing, safety glasses, face shield, hard hat, rubber gloves, clampstick, hotstick, etc.

Following is important safety information. For safe installation and operation of this equipment, be sure to read and understand all cautions and warnings.

### Hazard Statement Definitions

This manual may contain four types of hazard statements:

---

#### **DANGER**

Indicates an imminently hazardous situation which, if not avoided, will result in death or serious injury.

---

#### **WARNING**

Indicates a potentially hazardous situation which, if not avoided, could result in death or serious injury.

---

#### **CAUTION**

Indicates a potentially hazardous situation which, if not avoided, may result in minor or moderate injury.

---

#### **CAUTION**

Indicates a potentially hazardous situation which, if not avoided, may result in equipment damage only.

### Safety instructions

Following are general caution and warning statements that apply to this equipment. Additional statements, related to specific tasks and procedures, are located throughout the manual.

---

#### **DANGER**

**Hazardous voltage. Contact with hazardous voltage will cause death or severe personal injury. Follow all locally approved safety procedures when working around high- and low-voltage lines and equipment.**

G103.3

---

#### **WARNING**

**Before installing, operating, maintaining, or testing this equipment, carefully read and understand the contents of this manual. Improper operation, handling or maintenance can result in death, severe personal injury, and equipment damage.**

G101.0

---

#### **WARNING**

**This equipment is not intended to protect human life. Follow all locally approved procedures and safety practices when installing or operating this equipment. Failure to comply can result in death, severe personal injury and equipment damage.**

G102.1

---

#### **WARNING**

**Power distribution and transmission equipment must be properly selected for the intended application. It must be installed and serviced by competent personnel who have been trained and understand proper safety procedures. These instructions are written for such personnel and are not a substitute for adequate training and experience in safety procedures. Failure to properly select, install or maintain power distribution and transmission equipment can result in death, severe personal injury, and equipment damage.**

G122.2

## Product information

### Introduction

Eaton's Cooper Power™ series QD8 Quik-Drive tap-changer micro-switch replacement kit provides the parts and installation instructions for replacing the micro-switches on the polymer version of the QD8 Quik-Drive tap-changer. There are seven micro-switches found on the QD8 tap-changer; a neutral switch, two logic switches, two safety (limit) switches, and two holding switches. See Service Information MN225009EN for holding switch replacement instructions.

### Read this manual first

Read and understand the contents of this manual and follow all locally approved procedures and safety practices before installing or operating this equipment.

### Acceptance and initial inspection

Each kit is in good condition when accepted by the carrier for shipment. Upon receipt, inspect the shipping container for signs of damage. Unpack the kit and inspect it thoroughly for damage incurred during shipment. If damaged is discovered, file a claim with the carrier immediately.

### Handling and storage

Be careful during handling and storage of the kit to minimize the possibility of damage. If the kit is to be stored for any length of time prior to installation, provide a clean, dry storage area.

### Quality standards

ISO 9001 Certified Quality Management System

### Additional information

These instructions cannot cover all details or variations in the equipment, procedures, or process described nor provide directions for meeting every possible contingency during installation, operation, or maintenance. For additional information, contact your representative.

## Parts supplied

Item	Part Number	Description	Qty
1	2291660A01	Micro-switch	1

## Tools required

- 5/32 inch Allen wrench
- 9/64 inch Allen wrench
- 1/4 inch combination wrench
- 3/16 inch nut driver
- Needle-nose pliers
- Torque wrench
- Loctite® 243 Threadlocker



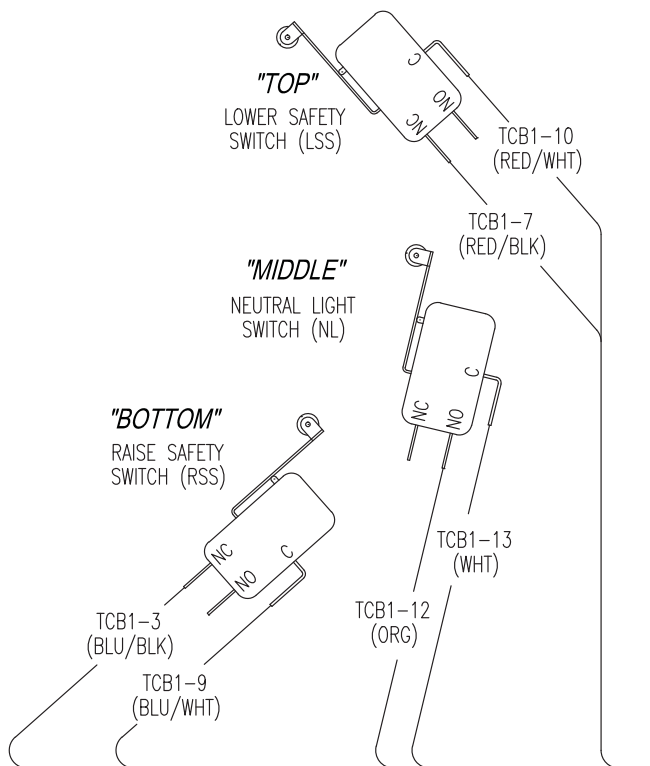
Figure 1. QD8 Micro-switch

## Installation procedure

1. This procedure may be completed without removal of the tap-changer from the voltage regulator. Carefully follow the procedures for partially untanking a voltage regulator in *Service Information MN225008EN, VR-32 Voltage Regulator with Quik-Drive Tap-Changer Installation, Operation, and Maintenance Instructions*.

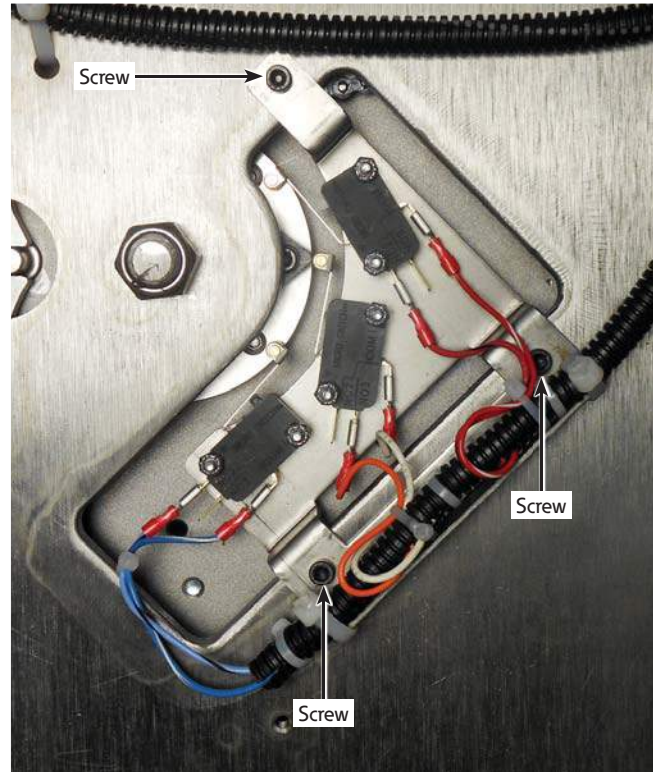
## Neutral and safety switches

2. Identify the switches to be replaced and the position of these switches on the tap changer. See Figure 2 for neutral and safety switch replacement and Figure 5 for logic switch replacement.



**Figure 2. QD8 neutral and safety micro-switches placement and connections**

3. Using a 9/64" Allen wrench, remove the three screws holding the switch bracket to the front of the tap changer. See Figure 3.



**Figure 3. Remove screws holding the bracket**

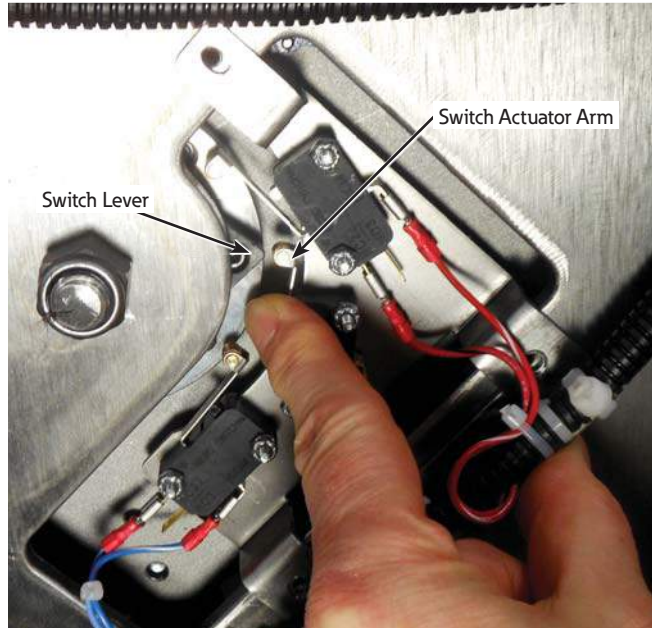
4. Remove the two screws attaching the switch to the bracket using 3/16" nut driver and 1/4" wrench.
5. Disconnect the wires, using a needle-nose pliers by pulling the connectors from the blade terminals on the removed switch.
6. Connect the wires to the new switch by sliding the connectors onto the bladed terminals. Make sure the wires are connected to the correct terminals. View Figure 2 as a guide for the wire connections.
7. Install the new switch on the bracket using the screws removed in step 4, the 3/16" nut driver, and 1/4" wrench. Make sure the switches are oriented correctly. Tighten the screws and nuts to a torque of 4–5 in-lbs. (0.5–0.6 Nm).
8. Repeat steps 4–7 for each switch being replaced.
9. Apply a small amount of Loctite® 243 Threadlocker on each of the bracket screws removed in step 3.

## IMPORTANT

**Take care when installing the switch assembly to avoid damaging the switch actuator arm.**



- Position the switch bracket in place while depressing any switch that may come in contact with the switch lever. If the tap changer is in the neutral position, it will be the neutral switch that must be depressed so that it is not damaged. See Figure 4.

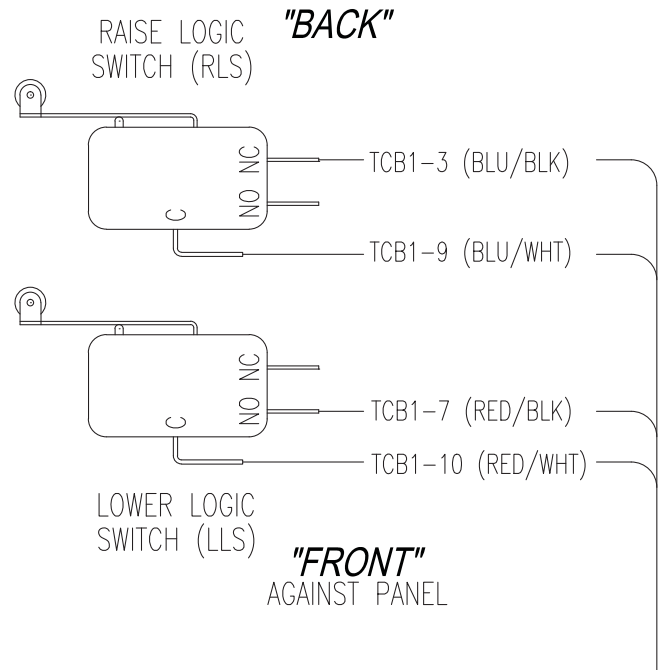


**Figure 4. Depressing the neutral switch actuator arm so that it is not damaged by the switch lever**

- Install the three screws to attach the switch bracket and tighten them to a torque of 18–20 in-lbs. (2.0–2.3 Nm).
- Insure that the tap changer is in the neutral position after completing the installation. See the section **Placing tap-changer into neutral** located after the installation procedures.

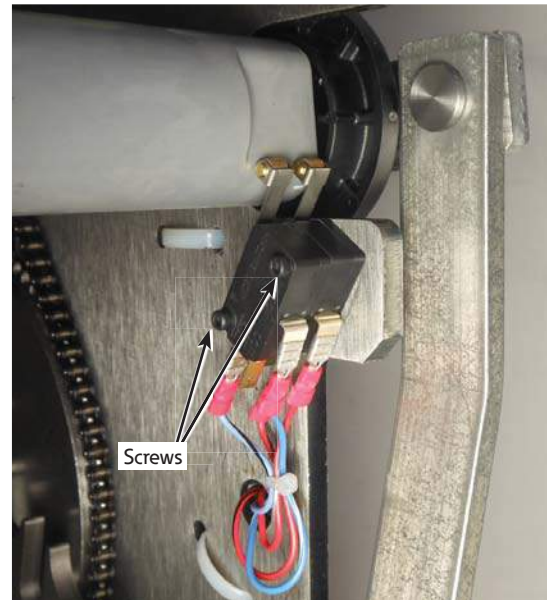
**Logic switches**

- Identify the switches to be replaced and the position of these switches on the tap changer. See Figure 5.

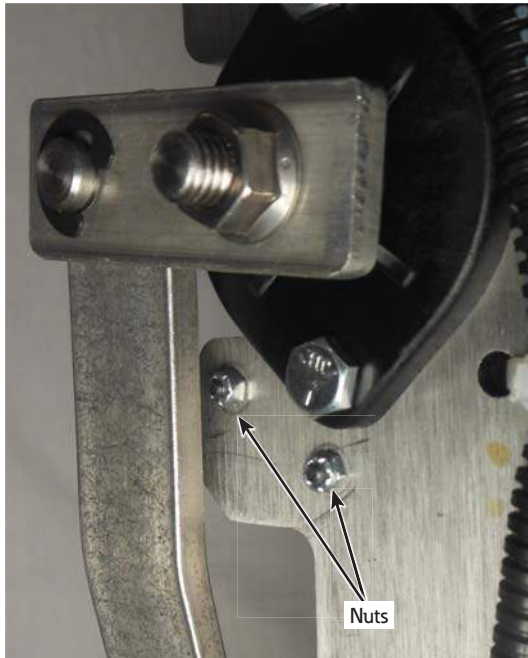


**Figure 5. QD8 logic micro-switches placement connections**

- Using a 5/32" Allen wrench and 1/4" wrench, remove the screw attaching the switches to the tap changer. See Figure 6 and Figure 7. Take care to avoid dropping hardware into the tank.



**Figure 6. QD8 logic micro-switch screws**

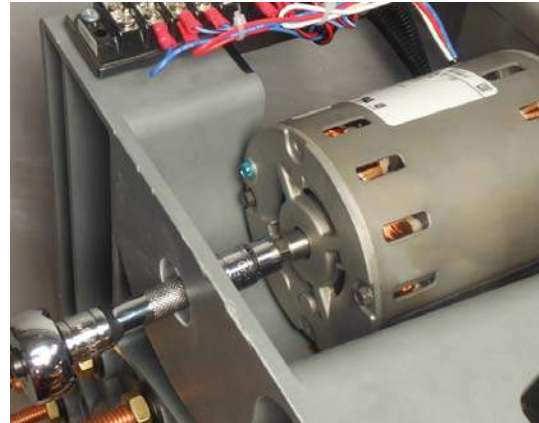


**Figure 7. QD8 logic micro-switch nuts**

15. Disconnect the wires using a needle-nose pliers by pulling the connectors from the blade terminals on the removed switch. Repeat for each switch being replaced.
16. Connect the wires to the new switch by sliding the connectors onto the bladed terminals. Make sure the wires are connected to the correct terminals. View Figure 5 as a guide for the wire connections. Repeat for each switch being replaced.
17. Insert the screws through the pair of switches and then through the holes in the steel tap-changer plate.
18. Reinstall the nuts onto the ends of the screws. It may be necessary to hold the nut behind the reversing segment actuator arm with a needle-nose pliers to get it started. Take care to avoid dropping hardware into the tank.
19. Tighten the screws and nuts to a torque of 4–5 in-lbs. (0.5–0.6 Nm).
20. Insure that the tap changer is in the neutral position when finished with the installation. See the section **Placing tap-changer into neutral** located after the installation procedures.

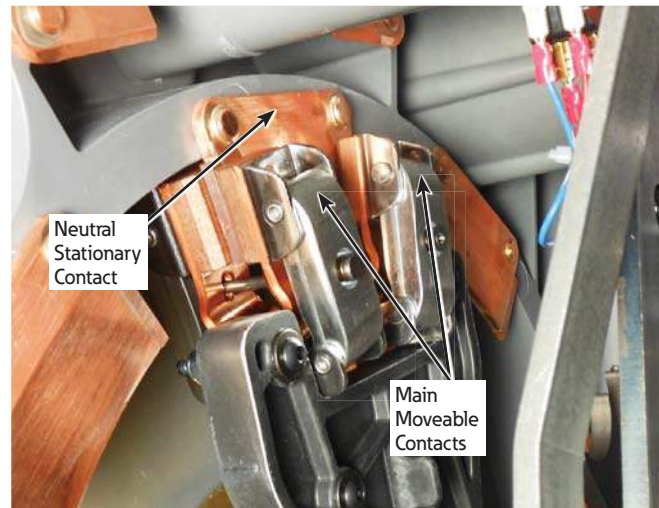
## Placing tap-changer into neutral

1. Place a 3/8" socket with extension and ratchet on the output shaft of the motor; rotate the motor until the contacts and other components are aligned in the neutral position. See Figure 8.



**Figure 8. Rotating the motor shaft**

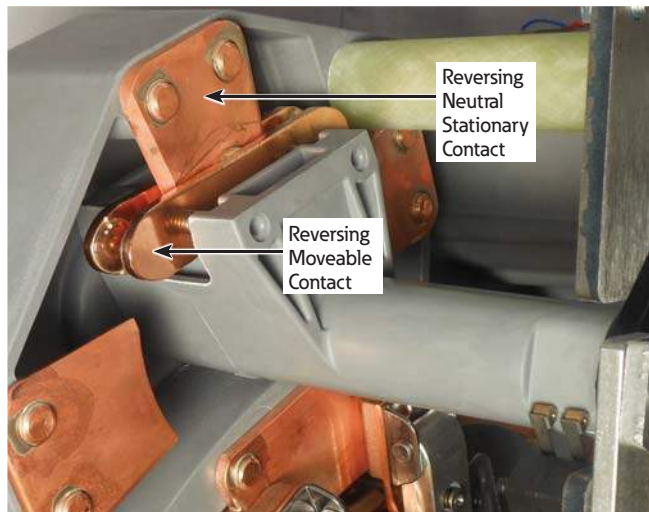
2. Confirm that the regulator is in the neutral position:
  - A. Main movable contacts are located on the neutral stationary contact, which is located at the 11 o'clock position. See Figure 9.



**Figure 9. Neutral stationary contact position for main moveable contacts**

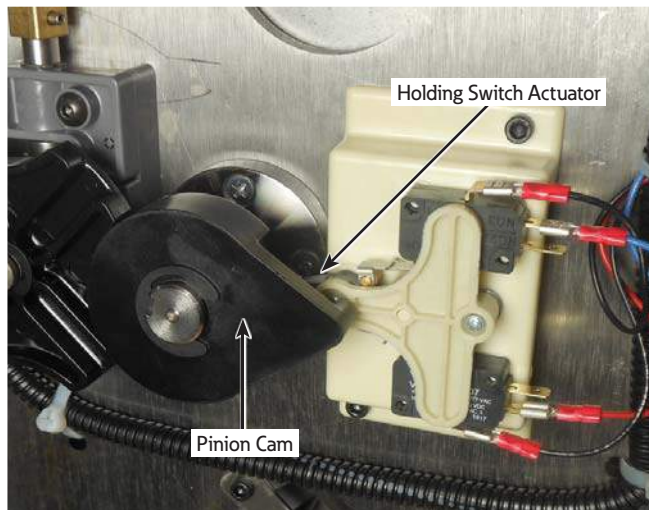


- B. The reversing movable contact is located on the reversing neutral stationary contact. See Figure 10.



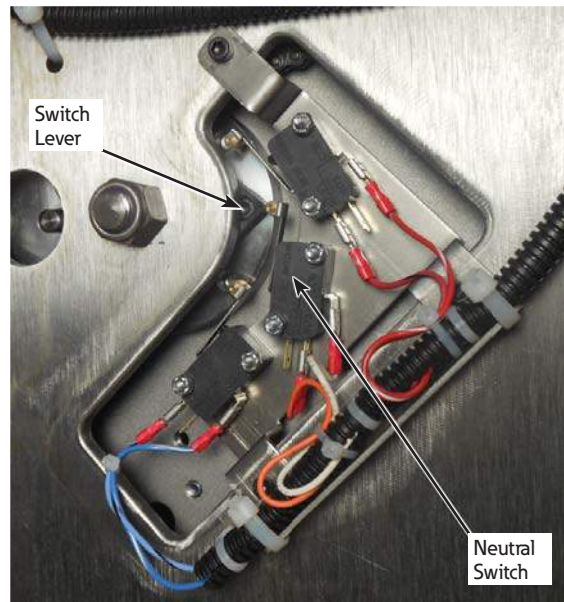
**Figure 10. Neutral position for reversing movable**

- C. The pinion cam is pointing to the right over the holding switch actuator. See Figure 11.



**Figure 11. Neutral position for position indicator pinion cam and holding switch**

- D. The neutral switch will be depressed with the switch lever. See Figure 12.



**Figure 12. Neutral switch is depressed**

This page is intentionally left blank.

This page is intentionally left blank.



**Eaton**  
1000 Eaton Boulevard  
Cleveland, OH 44122  
United States  
Eaton.com

**Eaton's Power Systems Division**  
2300 Badger Drive  
Waukesha, WI 53188  
United States  
Eaton.com/cooperpowerseries

**EAT•N**  
*Powering Business Worldwide*

© 2016 Eaton  
All Rights Reserved  
Printed in USA  
Publication No. MN225040EN/July 2016  
5740794B05 Rev 0

Eaton is a registered trademark.

All trademarks are property  
of their respective owners.

For Eaton's Cooper Power series product  
information  
call 1-877-277-4636 or visit:  
[www.eaton.com/cooperpowerseries](http://www.eaton.com/cooperpowerseries).