

QD5 Quik-Drive tap-changer main stationary contact assembly kit 5791646A24 installation instructions



DISCLAIMER OF WARRANTIES AND LIMITATION OF LIABILITY

The information, recommendations, descriptions and safety notations in this document are based on Eaton Corporation's ("Eaton") experience and judgment and may not cover all contingencies. If further information is required, an Eaton sales office should be consulted. Sale of the product shown in this literature is subject to the terms and conditions outlined in appropriate Eaton selling policies or other contractual agreement between Eaton and the purchaser.

THERE ARE NO UNDERSTANDINGS, AGREEMENTS, WARRANTIES, EXPRESSED OR IMPLIED, INCLUDING WARRANTIES OF FITNESS FOR A PARTICULAR PURPOSE OR MERCHANTABILITY, OTHER THAN THOSE SPECIFICALLY SET OUT IN ANY EXISTING CONTRACT BETWEEN THE PARTIES. ANY SUCH CONTRACT STATES THE ENTIRE OBLIGATION OF EATON. THE CONTENTS OF THIS DOCUMENT SHALL NOT BECOME PART OF OR MODIFY ANY CONTRACT BETWEEN THE PARTIES.

In no event will Eaton be responsible to the purchaser or user in contract, in tort (including negligence), strict liability or otherwise for any special, indirect, incidental or consequential damage or loss whatsoever, including but not limited to damage or loss of use of equipment, plant or power system, cost of capital, loss of power, additional expenses in the use of existing power facilities, or claims against the purchaser or user by its customers resulting from the use of the information, recommendations and descriptions contained herein. The information contained in this manual is subject to change without notice.

Contents

SAFETY INFORMATION

Safety information	iv
--------------------------	----

PRODUCT INFORMATION

Introduction	1
Acceptance and initial inspection	1
Handling and storage	1
Standards	1
Parts supplied	1
Tools required	1

INSTALLATION PROCEDURE

Stationary contact removal and installation instructions	2
Placing tap-changer into neutral	4



Safety for life



Eaton meets or exceeds all applicable industry standards relating to product safety in its Cooper Power™ series products. We actively promote safe practices in the use and maintenance of our products through our service literature, instructional training programs, and the continuous efforts of all Eaton employees involved in product design, manufacture, marketing, and service.

We strongly urge that you always follow all locally approved safety procedures and safety instructions when working around high voltage lines and equipment, and support our “Safety For Life” mission.

Safety information

The instructions in this manual are not intended as a substitute for proper training or adequate experience in the safe operation of the equipment described. Only competent technicians who are familiar with this equipment should install, operate, and service it.

A competent technician has these qualifications:

- Is thoroughly familiar with these instructions.
- Is trained in industry-accepted high and low-voltage safe operating practices and procedures.
- Is trained and authorized to energize, de-energize, clear, and ground power distribution equipment.
- Is trained in the care and use of protective equipment such as arc flash clothing, safety glasses, face shield, hard hat, rubber gloves, clampstick, hotstick, etc.

Following is important safety information. For safe installation and operation of this equipment, be sure to read and understand all cautions and warnings.

Hazard Statement Definitions

This manual may contain four types of hazard statements:

DANGER

Indicates an imminently hazardous situation which, if not avoided, will result in death or serious injury.

WARNING

Indicates a potentially hazardous situation which, if not avoided, could result in death or serious injury.

CAUTION

Indicates a potentially hazardous situation which, if not avoided, may result in minor or moderate injury.

CAUTION

Indicates a potentially hazardous situation which, if not avoided, may result in equipment damage only.

Safety instructions

Following are general caution and warning statements that apply to this equipment. Additional statements, related to specific tasks and procedures, are located throughout the manual.

DANGER

Hazardous voltage. Contact with hazardous voltage will cause death or severe personal injury. Follow all locally approved safety procedures when working around high- and low-voltage lines and equipment.

G103.3

WARNING

Before installing, operating, maintaining, or testing this equipment, carefully read and understand the contents of this manual. Improper operation, handling or maintenance can result in death, severe personal injury, and equipment damage.

G101.0

WARNING

This equipment is not intended to protect human life. Follow all locally approved procedures and safety practices when installing or operating this equipment. Failure to comply can result in death, severe personal injury and equipment damage.

G102.1

WARNING

Power distribution and transmission equipment must be properly selected for the intended application. It must be installed and serviced by competent personnel who have been trained and understand proper safety procedures. These instructions are written for such personnel and are not a substitute for adequate training and experience in safety procedures. Failure to properly select, install or maintain power distribution and transmission equipment can result in death, severe personal injury, and equipment damage.

G122.3

Product information

Introduction

Eaton's Cooper Power™ series QD5 Quik-Drive tap-changer main stationary contact assembly kit and installation instructions gives customers the ability and guidance to replace the main stationary contacts during maintenance cycles when contact erosion has occurred to the point of needing replacement.

Refer to *Service Information MN225003EN CL-7 Series Control Installation, Operation, and Maintenance Instructions* for information on the CL-6 voltage regulator control. Refer to *Service Information MN225016EN CL-6 Series Control Installation, Operation, and Maintenance Instructions* for information on the CL-6 voltage regulator control. Refer to *Service Information MN225008EN VR-32 Voltage Regulator with Quik-Drive Tap-Changer Installation, Operation, and Maintenance Instructions* for information on Eaton's voltage regulator with Quik-Drive tap-changer.

Read This Manual First

Read and understand the contents of this manual and follow all locally approved procedures and safety practices before installing or operating this equipment.

Additional Information

These instructions cannot cover all details or variations in the equipment, procedures, or process described nor provide directions for meeting every possible contingency during installation, operation, or maintenance. For additional information, contact your Eaton representative.

Acceptance and Initial Inspection

Each stationary contact assembly kit is in good condition when accepted by the carrier for shipment. Upon receipt, inspect the shipping container for signs of damage. Unpack the stationary contact assembly kit and inspect it thoroughly for damage incurred during shipment. If damaged is discovered, file a claim with the carrier immediately.

Handling and Storage

Be careful during handling and storage of the stationary contact assembly kit to minimize the possibility of damage. If the stationary contact assembly kit is to be stored for any length of time prior to installation, provide a clean, dry storage area.

Standards

ISO 9001 Certified Quality Management System

Parts supplied

Item	Part Number	Description	Qty
1	0791646A24	Stationary Contact	1

Tools required

- Ratchet Wrench
- 9/16 inch Deep-well Socket
- Torque Wrench in-lbs
- 3/8 inch Socket



Figure 1. Main stationary contact.

Installation procedure

Stationary contact removal and installation instructions

1. Each QD5 tap-changer has nine main stationary contacts. Of these, eight are tap contacts and one is the neutral stationary contact. See Figure 2.

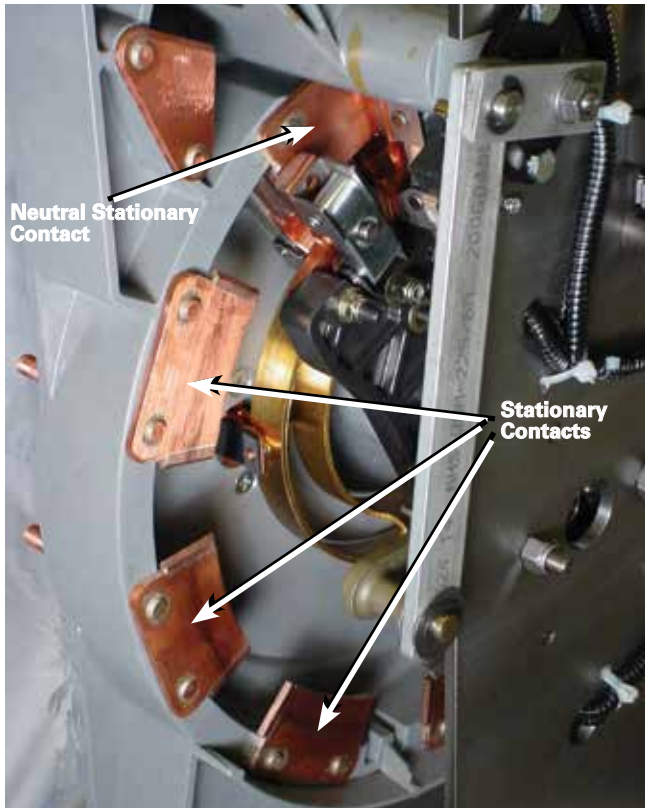

Figure 2. Stationary contacts.

2. Use a 9/16" deep-well socket and ratchet to loosen and remove the nuts and washers from each stationary contact stud. See Figure 3.



Figure 3. Removal of contact hardware.

3. Remove the stationary contact from the contact assembly panel. See Figure 3.

4. Install the new stationary contact into the mounting holes in the contact assembly board for the contact being replaced. See Figure 4.



Figure 4. Stationary contact removal.

5. Place a flat washer and nut on each stud. Use a 9/16" deep-well socket and ratchet to tighten the nuts. Using a torque wrench, tighten the nuts to a torque of 80–90 in-lbs (9.0–10.2 Nm). See Figure 5.



Figure 5. Contact hardware installation.

6. Repeat Steps 1 through 5 for each stationary contact to be replaced.
7. When the movable contacts are located on the stationary contact to be replaced, the movable contacts must be moved. Place a 3/8" socket onto the rear shaft of the motor. See Figure 6. Using a ratchet, rotate the motor to position the movable contacts off of the contact to be replaced.

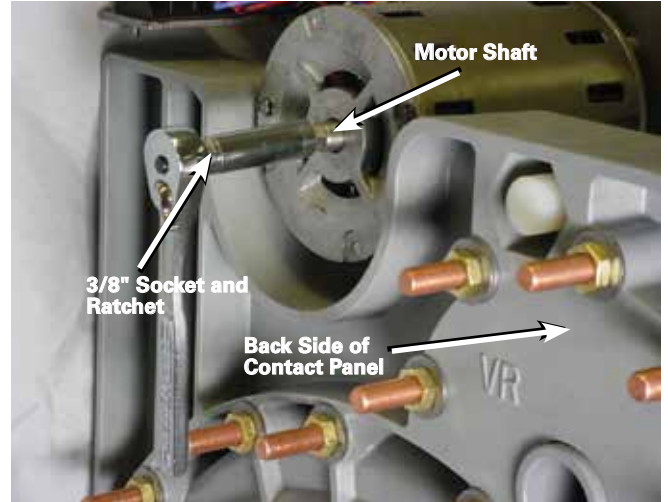

Figure 6. Motor and movable contact rotation.

8. Once the work has been completed, place the tap-changer in the neutral position.

Placing tap-changer into neutral

1. Place a 3/8" socket and ratchet on the output shaft of the motor; rotate the motor so that the contacts and other components are aligned in the neutral position
2. Confirm that the regulator is in the neutral position.
 - A. Main movable contacts are located on the neutral stationary contact, which is located at the 11 o'clock position and under the reversing switch movable contact assembly. See Figure 7.

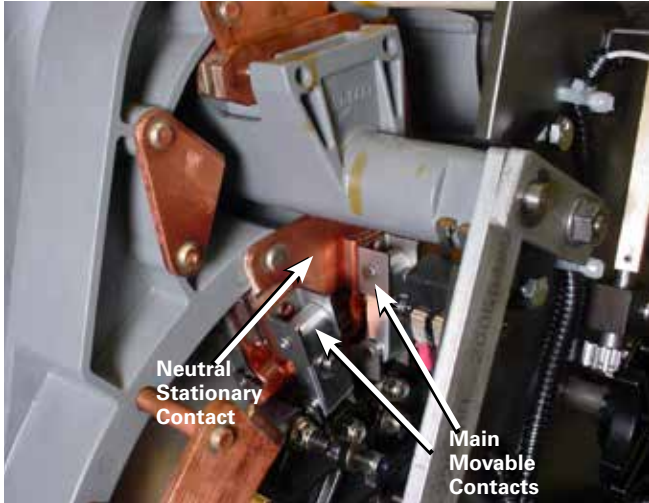

Figure 7. Neutral position for main movable contacts.

- B. The reversing movable contact is located on the reversing neutral stationary contact. See Figure 8.

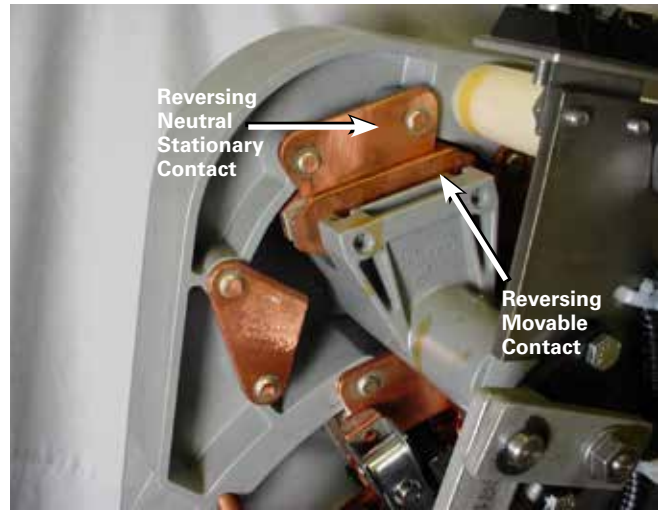

Figure 8. Neutral position for reversing movable.

- C. The pinion cam is pointing to the right over the holding switch actuator. See Figure 9.

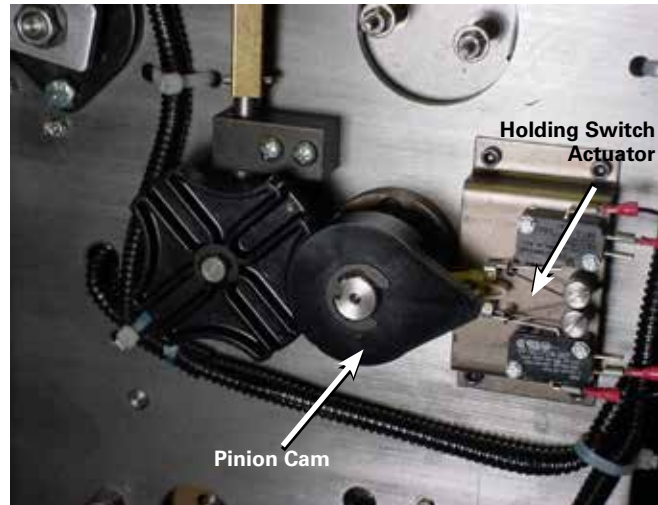

Figure 9. Neutral position for position indicator pinion cam and holding switch.



Eaton
1000 Eaton Boulevard
Cleveland, OH 44122
United States
Eaton.com

**Eaton's Cooper Power Systems
Division**
2300 Badger Drive
Waukesha, WI 53188
United States
Eaton.com/cooperpowerseries

EATON
Powering Business Worldwide

© 2016 Eaton
All Rights Reserved
Printed in USA
Publication No. MN225026EN/March 2016

Eaton is a registered trademark.

All trademarks are property
of their respective owners.

For Eaton's Cooper Power series product
information call 1-877-277-4636 or visit:
www.eaton.com/cooperpowerseries.