

Forced-air cooling accessory, operation and maintenance instructions/parts information



EATON

Powering Business Worldwide

DISCLAIMER OF WARRANTIES AND LIMITATION OF LIABILITY

The information, recommendations, descriptions and safety notations in this document are based on Eaton Corporation's ("Eaton") experience and judgment and may not cover all contingencies. If further information is required, an Eaton sales office should be consulted. Sale of the product shown in this literature is subject to the terms and conditions outlined in appropriate Eaton selling policies or other contractual agreement between Eaton and the purchaser.

THERE ARE NO UNDERSTANDINGS, AGREEMENTS, WARRANTIES, EXPRESSED OR IMPLIED, INCLUDING WARRANTIES OF FITNESS FOR A PARTICULAR PURPOSE OR MERCHANTABILITY, OTHER THAN THOSE SPECIFICALLY SET OUT IN ANY EXISTING CONTRACT BETWEEN THE PARTIES. ANY SUCH CONTRACT STATES THE ENTIRE OBLIGATION OF EATON. THE CONTENTS OF THIS DOCUMENT SHALL NOT BECOME PART OF OR MODIFY ANY CONTRACT BETWEEN THE PARTIES.

In no event will Eaton be responsible to the purchaser or user in contract, in tort (including negligence), strict liability or otherwise for any special, indirect, incidental or consequential damage or loss whatsoever, including but not limited to damage or loss of use of equipment, plant or power system, cost of capital, loss of power, additional expenses in the use of existing power facilities, or claims against the purchaser or user by its customers resulting from the use of the information, recommendations and descriptions contained herein. The information contained in this manual is subject to change without notice.

Contents

DISCLAIMER OF WARRANTIES AND LIMITATION OF LIABILITY I

SAFETY FOR LIFE III

SAFETY INFORMATION III
 Safety instructions iii

PRODUCT INFORMATION 1
 Acceptance and initial inspection 1
 Handling and storage 1

OPERATION AND MAINTENANCE 1

PARTS INFORMATION 2



Safety for life



Eaton's Cooper Power series products meet or exceed all applicable industry standards relating to product safety. We actively promote safe practices in the use and maintenance of our products through our service literature, instructional training programs, and the continuous efforts of all Eaton employees involved in product design, manufacture, marketing and service.

We strongly urge that you always follow all locally approved safety procedures and safety instructions when working around high-voltage lines and equipment and support our "Safety For Life" mission.

Safety information

The instructions in this manual are not intended as a substitute for proper training or adequate experience in the safe operation of the equipment described. Only competent technicians, who are familiar with this equipment should install, operate and service it.

A competent technician has these qualifications:

- Is thoroughly familiar with these instructions.
- Is trained in industry-accepted high- and low-voltage safe operating practices and procedures.
- Is trained and authorized to energize, de-energize, clear, and ground power distribution equipment.
- Is trained in the care and use of protective equipment such as flash clothing, safety glasses, face shield, hard hat, rubber gloves, clampstick, hotstick, etc.

Following is important safety information. For safe installation and operation of this equipment, be sure to read and understand all cautions and warnings.

Hazard Statement Definitions

This manual may contain four types of hazard statements:

DANGER

Indicates a hazardous situation which, if not avoided, will result in death or serious injury.

WARNING

Indicates a hazardous situation which, if not avoided, could result in death or serious injury.

CAUTION

Indicates a hazardous situation which, if not avoided, may result in minor or moderate injury.

CAUTION

Indicates a hazardous situation which, if not avoided, may result in equipment damage only.

Safety instructions

Following are general caution and warning statements that apply to this equipment. Additional statements, related to specific tasks and procedures, are located throughout the manual.

DANGER

Hazardous voltage. Contact with high voltage will cause death or severe personal injury. Follow all locally approved safety procedures when working around high- and low-voltage lines and equipment.

WARNING

Before installing, operating, maintaining, or testing this equipment, carefully read and understand the contents of this manual. Improper operation, handling or maintenance can result in death, severe personal injury, and equipment damage.

WARNING

This equipment is not intended to protect human life. Follow all locally approved procedures and safety practices when installing or operating this equipment. Failure to comply may result in death, severe personal injury and equipment damage.

WARNING

Power distribution and transmission equipment must be properly selected for the intended application. It must be installed and serviced by competent personnel who have been trained and understand proper safety procedures. These instructions are written for such personnel and are not a substitute for adequate training and experience in safety procedures. Failure to properly select, install or maintain power distribution and transmission equipment can result in death, severe personal injury, and equipment damage.

Product information

Introduction

Eaton's Cooper Power series forced-air cooling accessory, operation and maintenance instructions/parts information, provides basic information pertaining to the operation, physical layout, wiring schematic and parts for a forced-air cooling package. The forced-air cooling package may be factory or field installed. For field installation, factory installed provisions are required.

Read this manual first

Read and understand the contents of this manual and follow all locally approved procedures and safety practices before operating or maintaining this equipment.

Additional information

These instructions cannot cover all details or variations in the equipment, procedures, or process described nor provide directions for meeting every possible contingency during operation or maintenance. For additional information, contact your representative.

Acceptance and initial inspection

Each forced-air cooling accessory is in good condition when accepted by the carrier for shipment. Upon receipt, inspect the shipping container for signs of damage. Unpack the forced air cooling accessory and inspect it thoroughly for damage incurred during shipment. If damaged is discovered, file a claim with the carrier immediately.

Handling and storage

Be careful during handling and storage of the forced-air cooling accessory to minimize the possibility of damage. If the forced-air cooling accessory is to be stored for any length of time prior to operation and maintenance, provide a clean, dry storage area.

Standards

ISO 9001 Certified Quality Management System

Operation and maintenance

VR-32 voltage regulators, 333 kVA and larger, can be equipped with forced-air cooling. This allows their load capacity to be increased to 133% of their 55/65 °C rise ONAN rating as shown on the nameplate.

The forced-air-cooling equipment consists of:

- Fan control main power switch
- Top oil thermometer with two sets of normally open and normally closed contacts
- Manual-off-automatic fan control switch
- Fan control relay
- Fan with a 230 VAC 1 phase motor
- MOV (metal-oxide-varistor) arrester protection
- 6.25-amp fuse circuit protection
- Auxiliary control enclosure

Being completely self contained, the forced-air cooling on Cooper Power series regulators from Eaton requires no external source voltage. The power for forced-air-cooling is derived from a 230 VAC tertiary winding located on the regulator main core and coil assembly.

CAUTION

Equipment Damage. Forced-air cooling is operational only if the voltage regulator is applied at the nameplate nominal rated voltage. Operating the voltage regulator at any other voltage will result in a voltage other than the 230 VAC required by the fan motor. This could result in fan motor failure and overheating of the voltage regulator.

The main power switch for the forced-air cooling equipment is located in the voltage regulator main control enclosure and is identified on the schematic (Figure 2) as "V2". An MOV (metal oxide varistor) arrester provides overvoltage protection to the fan control circuit and is also located in the regulator main control enclosure. All of the other fan control components, 6 amp fuse, off-manual-automatic switch, and fan control relay, are located in an auxiliary control enclosure. The auxiliary control enclosure is attached to the bottom side of the regulator main control enclosure.

Forced-air cooling accessory, operation and maintenance instructions/parts information

The top oil thermometer provided with forced-air cooling is equipped with two switches, each having a normally open and normally closed contact. These switches are identified as "S1" and "S2" on the control schematic. Automatic control of the forced-air cooling is accomplished by the operation of switch "S1", which is factory preset to close at 75 °C. The differential temperature from make to break is 6-10 °C. The closing of switch "S1" energizes fan control relay "FR", closing the relay contacts, applying power to the fan motor. Switch "S2" is an alarm contact and is factory preset to close at 90 °C top oil temperature.

A manually operated "manual-off-automatic" fan control switch "FS" is located in the auxiliary control enclosure. This switch allows the forced-air cooling to be operated manually (fan on continuously), turned off, or operated in the automatic mode.

The cooling fan is equipped with a 230 VAC, single-phase, thermally protected motor and is attached to the voltage regulator panel type radiators using T-bolts.

Note: T-bolts are not used in a vertical installation of the motor.



CAUTION

Equipment Damage. Before un tanking the regulator, the oil level must be lowered below the level of the thermometer and the thermometer and well removed. Failure to remove the thermometer and well prior to lifting the regulator from the tank will cause damage to these parts.

A physical wiring diagram is shown in Figure 3 and the associated wiring color coding chart is shown in Table 1.

Parts information

Parts information is provided in Table 2, Figures 4 through 7.

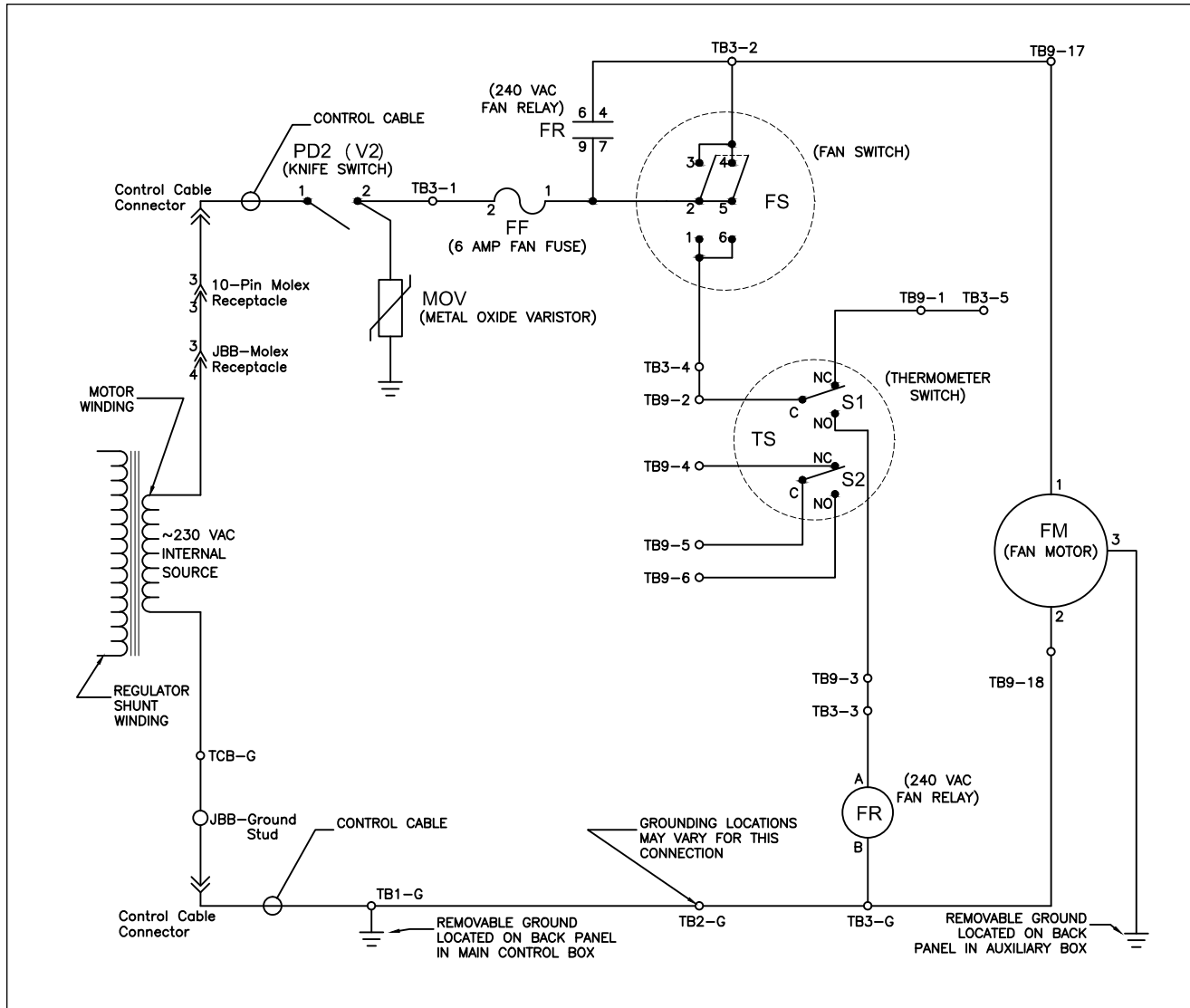

Figure 1. Schematic diagram

Forced-air cooling accessory, operation and maintenance instructions/parts information

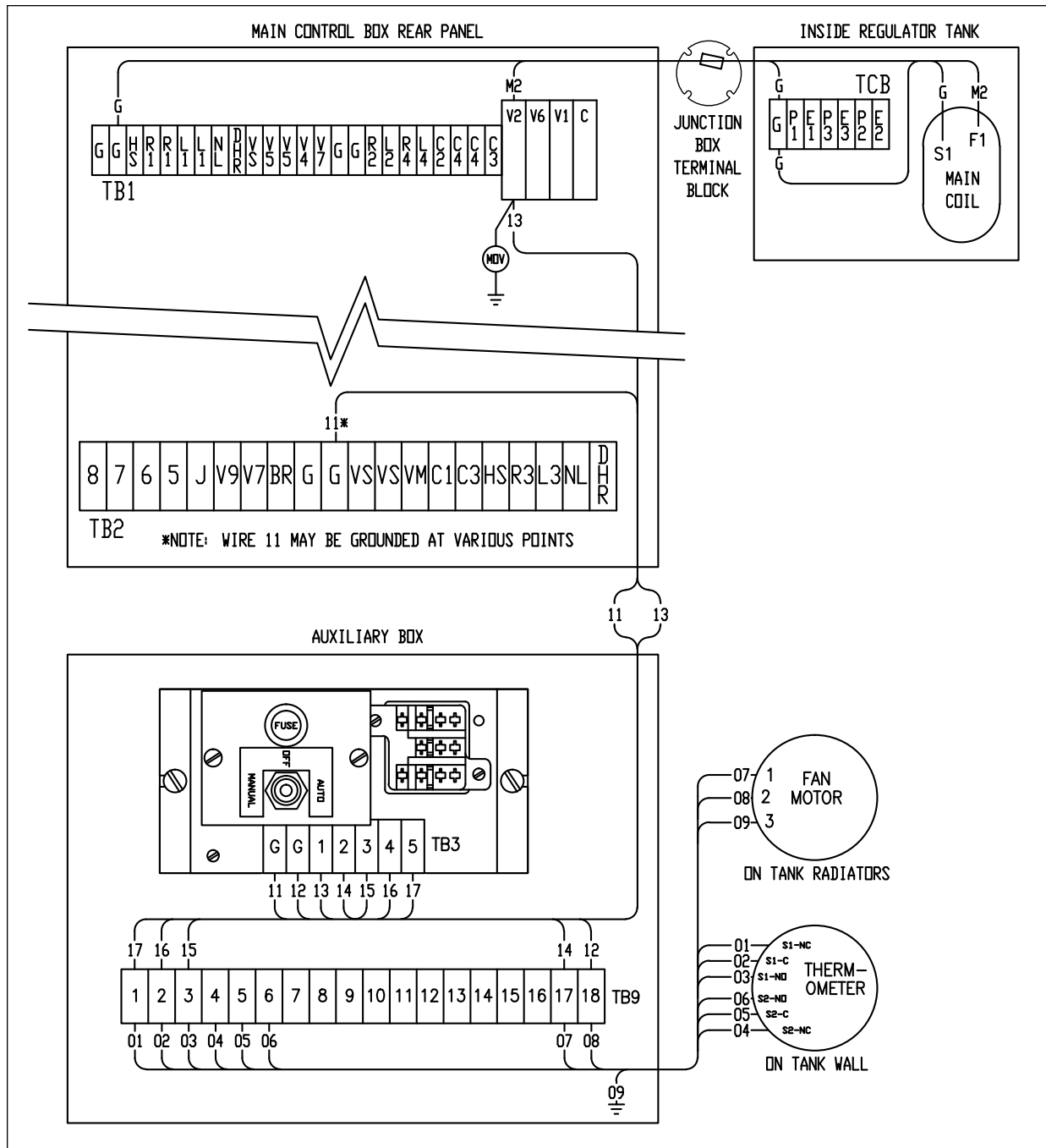

Figure 2. Physical diagram. Variations exist for control back panel arrangements, but connections are the same for all variations.

Forced-air cooling accessory, operation and maintenance instructions/parts information

Table 1. Wire color code chart

Wire number	Color	Wire number	Color	Wire number	Color
01	BLUE	07	BLACK	14	BLACK
02	RED	08	WHITE	15	BLACK
03	BLACK	09	GREEN	16	RED
04	ORANGE	11	WHITE	17	BLUE
05	YELLOW	12	WHITE	G	WHITE
06	BROWN	13	BROWN	M2	LT BLUE/BLACK

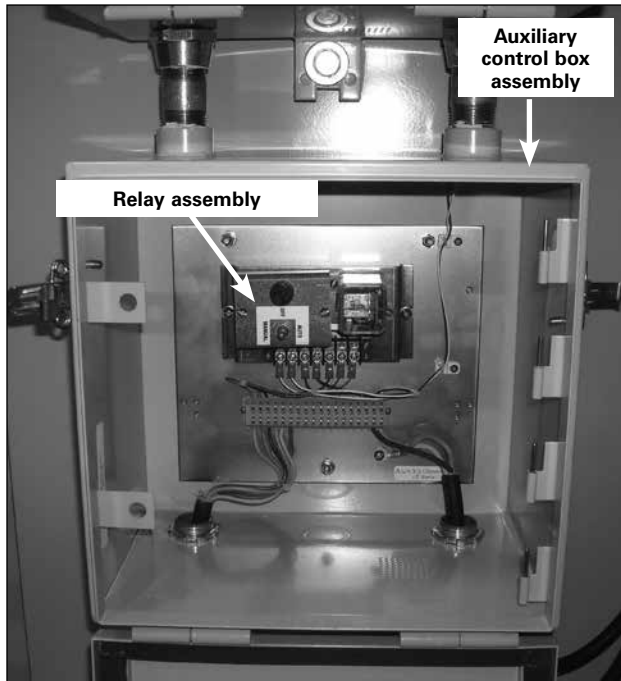

Figure 3. Relay and auxiliary control box assemblies

Table 2. Parts list for cooling accessory

Item number	Description
1	Relay Assembly
2	Auxiliary Control Box Assembly
3	MOV Surge Arrester
4	Knife Switch (3-blade, not shown) Knife Switch (4-blade)
5	Fan and Male Receptacle
6	Female Plug and 10-ft. Cable*
7	Thermometer with 5-ft Cable*
8	Fan Mounting Kit

* Other cable lengths available

Note: Parts and assemblies may vary slightly depending upon specific applications. Force air provisions required for installation of forced air package.

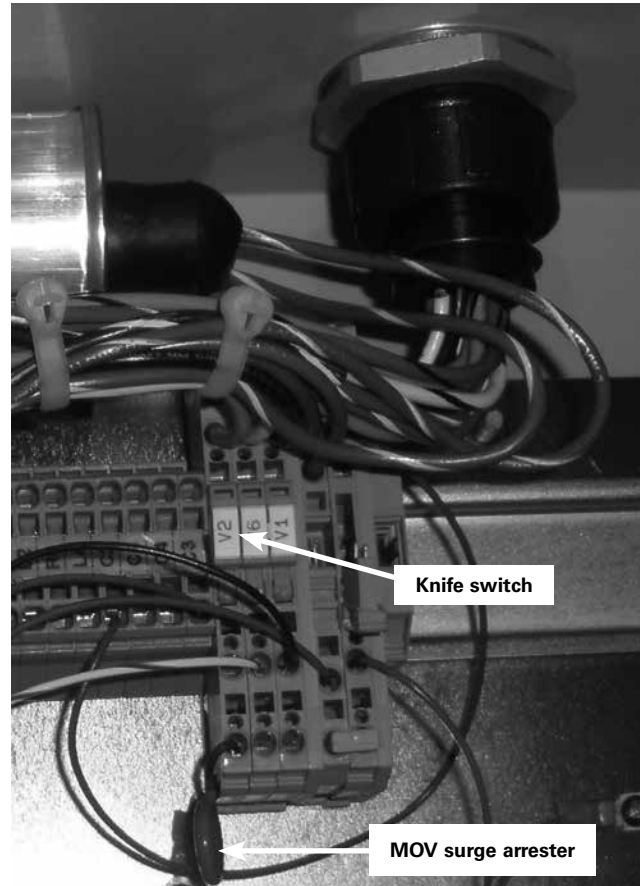

Figure 4. Mov surge arrester and knife switches

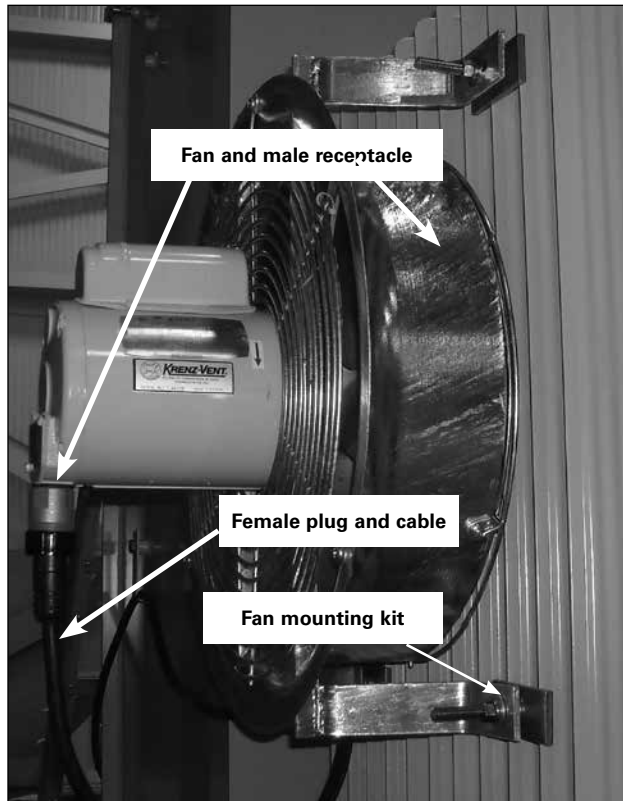

Figure 5. Fan and male receptacle with cables



Figure 6. Thermometer with cable

This page intentionally left blank.



Eaton
1000 Eaton Boulevard
Cleveland, OH 44122
United States
Eaton.com

Eaton's Power Systems Division
2300 Badger Drive
Waukesha, WI 53188
United States
Eaton.com/cooperpowerseries

EATON
Powering Business Worldwide

© 2017 Eaton
All Rights Reserved
Printed in USA
Publication No. MN225070EN
March 2017

Eaton is a registered trademark.

All trademarks are property
of their respective owners.

For Eaton's Cooper Power series product
information
call 1-877-277-4636 or visit:
www.eaton.com/cooperpowerseries.