

Instructions for Duct and Plenum Installation for Eaton 5/15 kV Type VacClad-W Arc Resistant Metal-Clad Switchgear and AMPGARD Arc Resistant Motor Control Centers



Contents

Description	Page
1: Introduction	2
2: Receiving, Handling, and Storage	4
3: Plenum Installation	5
4: Duct Installation	17
5: Inspection and Maintenance	22
6: Renewal Parts	22



Powering Business Worldwide

Read and understand these instructions before attempting installation, operation, or maintenance of this equipment. This equipment must be installed and serviced only by qualified electrical personnel. Retain this document for future use.

⚠ WARNING

HAZARD OF ELECTRICAL SHOCK OR BURN. OPERATING THE EQUIPMENT OUTSIDE OF ITS RATINGS MAY CAUSE FAILURE RESULTING IN PROPERTY DAMAGE, SEVERE PERSONAL INJURY, OR DEATH. THE EQUIPMENT MUST BE OPERATED WITHIN ITS NAMEPLATE RATINGS.

⚠ DANGER

ALL APPLICABLE SAFETY CODES, SAFETY STANDARDS, AND SAFETY REGULATIONS MUST BE STRICTLY ADHERED TO WHEN INSTALLING, OPERATING, OR MAINTAINING THIS EQUIPMENT.

Section 1: Introduction

1.1 Purpose

This instruction bulletin covers the installation of the plenum and duct for 5/15 kV Type VacClad-W Arc Resistant Metal-Clad Switchgear and AMPGARD Arc Resistant Motor Control Centers. It does not cover all possible contingencies, variations, and details that may arise during installation of this equipment.

1.2 Application and Description

Eaton supplied plenum and duct provides containment for arc exhaust due to an internal arcing fault in VCP-W Switchgear and/or AMPGARD Motor Controls. The plenum may be installed on switchgear only, motor control only, or on both assemblies. The plenum and duct are not compatible with any other product. See **Figure 1**.

1.3 Documentation Reference

For further information on installation and application, refer to the applicable technical data, publications, and/or industry standards.

For VC-W Arc Resistant Switchgear: IB02201001E

For AMPGARD Arc Resistant Motor Control Centers: IB48076

Download Eaton electronic information from www.eaton.com/electrical.

1.4 Eaton Contact Information

For the location of your nearest Eaton sales office or distributor, call toll-free 1-800-525-2000 or log onto www.eaton.com/electrical. Eaton Services and Systems (EESS) can be reached at 1-800-498-2678.

1.5 Modifications to Plenum and Duct

ANY MODIFICATIONS TO THE PLENUM AND DUCT OUTSIDE OF ASSEMBLY INSTRUCTIONS IN THIS DOCUMENT COMPROMISES COMPLIANCE WITH ANSI/IEEE C37.20.7. Please contact the factory with any related questions.

1.6 Safety Precautions

Only qualified electrical personnel with training and experience on high-voltage apparatus shall be permitted to work on this equipment. They shall be familiar with the work to be performed, as well as industry and local safety procedures and standards.

1. Read and understand these instructions before attempting installation, operation, or maintenance of the switchgear assembly.
2. Disconnect all low voltage and medium voltage power sources to the switchgear assembly before working on the equipment per Occupational Safety and Health Act (OSHA) and lockout procedures. Verify that the voltage has been removed. Ground load and line side connections. Observe National Electrical Code (NEC), OSHA, and local procedures and standards. This includes visual inspections while the door is open, making any adjustments inside or outside the enclosure, performing maintenance, or installing replacement parts.
3. Never leave a breaker in an intermediate position in its compartment. Always continue to lever the breaker to the fully connected or withdrawn / test position.
4. Never try to disconnect or open the secondary circuit of a current transformer that is carrying load current. In this situation, the transformer can develop a dangerous high voltage.
5. The user is responsible for conforming to all applicable code requirements with respect to grounding the switchgear assembly.

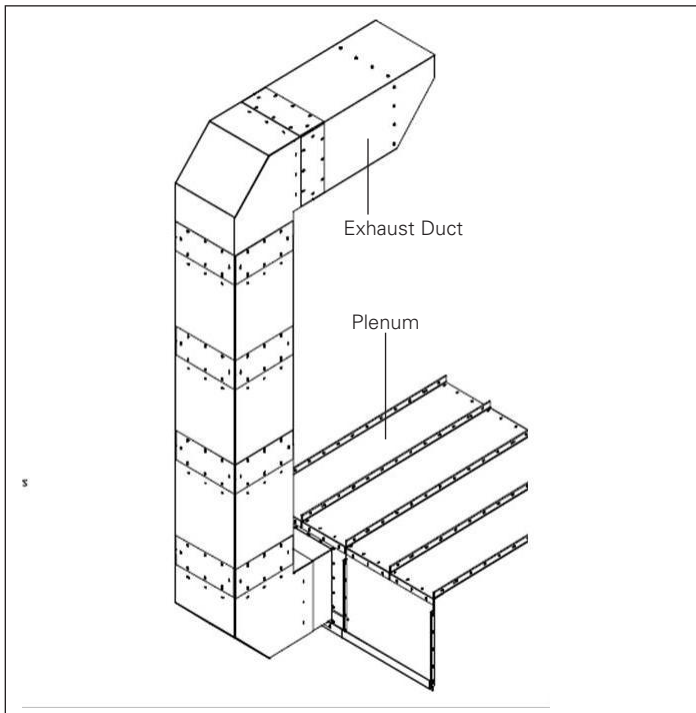

Figure 1. Plenum and Duct

⚠ CAUTION

**BEFORE ATTEMPTING ANY WORK, EITHER DE-ENERGIZE THE CIRCUIT
BY OPENING THE BREAKER OR SHORT-CIRCUIT THE SECONDARY OF THE
CURRENT TRANSFORMER**

⚠ CAUTION

BEFORE ENERGIZING THE SWITCHGEAR ASSEMBLY, ENSURE THAT:

- The switchgear assembly is secured on a true and level surface.
 - All hardware is in place and torqued per Section 3.1, Table 4.
 - No tools or objects are left inside the enclosure.
 - All devices, covers, doors, panels, etc., are secured.
 - Use adequate fall protection when working above ground level.
-

1.7 Lineup depth

Arc resistant VacClad may vary in depth from 96" to 120" due to cable entry and component content. Standard plenum designs will not cover the front module of the switchgear and will be flush with the rear of the 96" deep design. The rear of the plenum for the 108" and 120" deep designs will be set forward 12" and 24" respectively from the back of the switchgear. The only exception is for transition sections that connect to AMPGARD. These vertical sections will be completely covered by the plenum up to 108" deep. See the figures below for details.

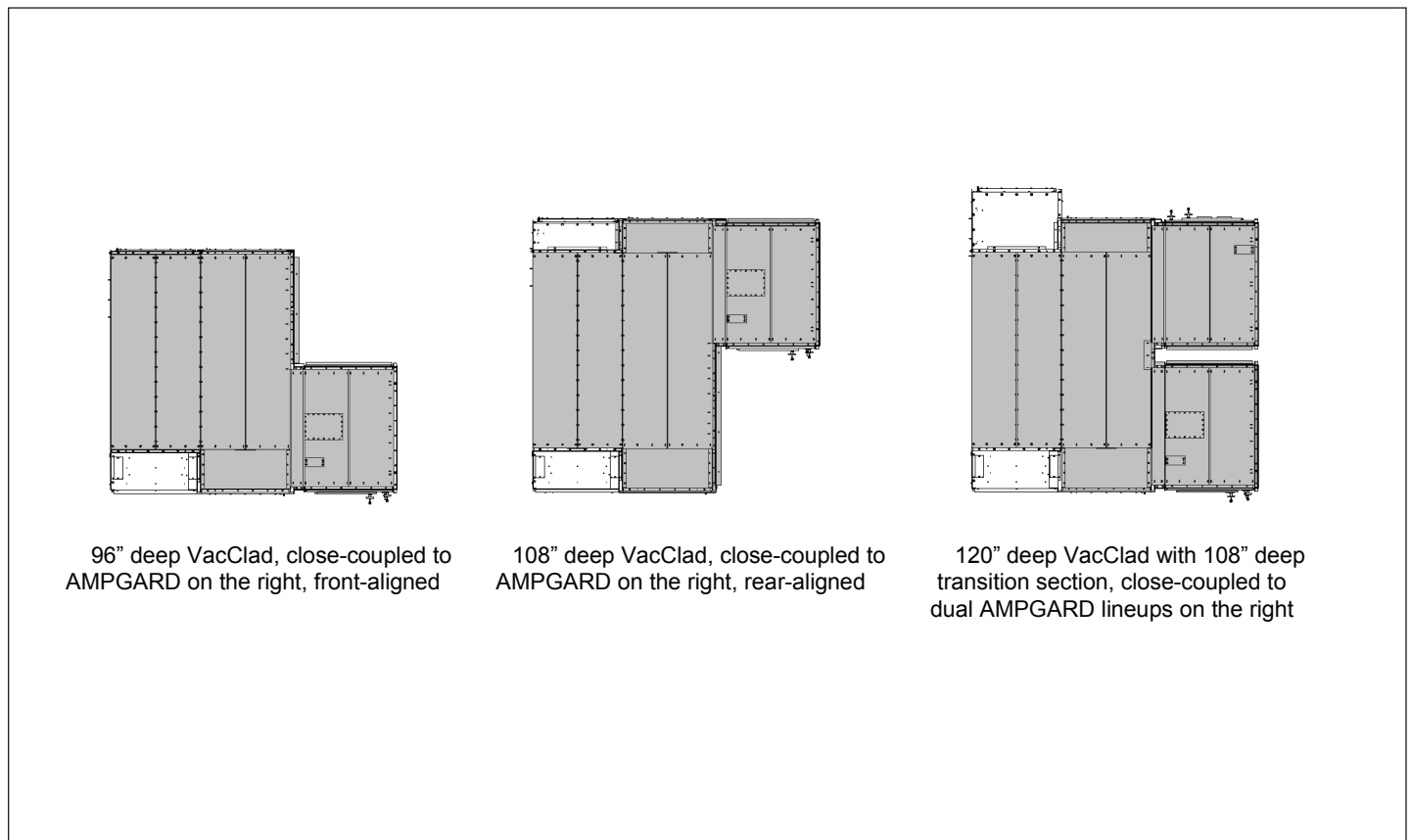

Figure 2. VacClad close-coupled to AMPGARD Lineup Depths - plan view

Section 2: Receiving, Handling, and Storing Plenum and Duct

2.1 Receiving

The plenum and duct are usually shipped to the customer assembled in shipping splits usually two or three sections wide. Refer to drawings for the location of each shipping split on the lineup.

Each order ships with a box labeled "Installation Parts". This box contains the packing list. The packing list identifies all cartons and crates. Each carton and crate is labeled with the shop order number and a shipping weight.

Accept items from shipping carrier if all items described on the packing list have been received. If the switchgear has been damaged, file a claim as soon as possible with the carrier and notify the nearest Eaton representative.

If the plenum and duct are to be installed upon receipt, unpack and handle according to Section 2.2. If the plenum and duct are to be stored, see Section 2.3.

2.2 Handling

Refer to Table 1 for the approximate weights of the various plenum and duct groups.

Plenum will arrive on a pallet as shown in **Figure 3**. Use a fork truck to maneuver the pallet into the desired position and remove packaging. Many openings in the plenum will have shipping braces across them for rigidity. Leave these in place until the plenum is placed onto the switchgear.

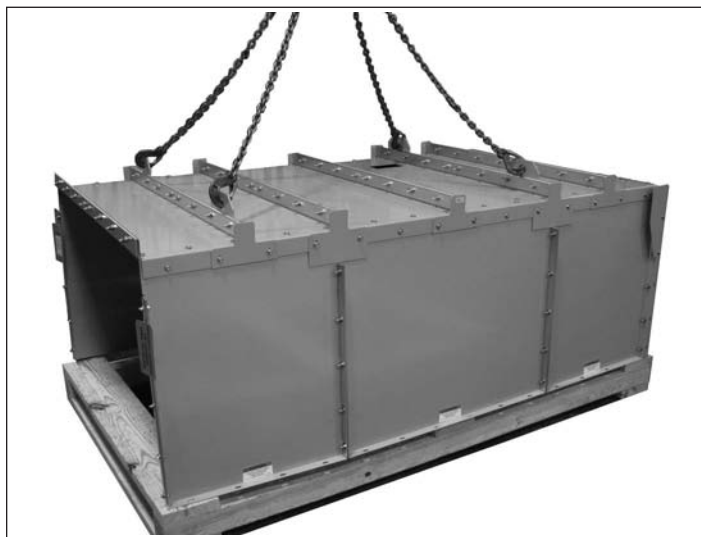

Figure 3. Handling Plenum.

Table 1. Plenum and Duct Weights

Equipment Type	Section	Section Width Inches (mm)	Arc Resistant Rating			
			30 kA	50 kA	49 kA	63 kA
			Lbs (kg)	Lbs (kg)	Lbs (kg)	Lbs (kg)
VacClad	lineup end	36 (910)	–	–	–	264 (120)
VacClad	within lineup	36 (910)	–	–	–	183 (83.2)
MVC	lineup end	36 (910)	216 (98.2)	244 (110.9)	164 (74.5)	–
MVC	within lineup	36 (910)	171 (77.7)	188 (85.5)	117 (53.2)	–
MVC	lineup end	24 (610)	168 (76.4)	179 (81.4)	134 (60.9)	–
MVC	within lineup	24 (610)	123 (55.9)	124 (56.4)	88 (40)	–

The preferred method of lifting and maneuvering shipping sections into their final position is with an overhead crane. Lifting eyes are bolted to the top of each shipping group. Using a 4-leg bridle sling chain, place one hook through each of the four eyes as shown in **Figure 3** to lift and move the group. No leg of the sling shall be at an angle greater than 45 degrees from the vertical – use a spreader beam if necessary to correct this condition. Make sure the shipping braces are left in place while lifting the plenum. After the group has been moved into installation position, remove the lifting members and shipping braces, and discard them.

⚠ DANGER

THE PLENUM LIFTING EYES ARE MEANT FOR LIFTING THE PLENUM ONLY. DO NOT USE THEM TO LIFT A COMPLETE VERTICAL SECTION WITH THE PLENUM ATTACHED. PERSONNEL INJURY OR EQUIPMENT DAMAGE WILL LIKELY RESULT.

⚠ DANGER

FAILURE TO FOLLOW ALL THE INSTRUCTIONS IN THIS DOCUMENT MAY RESULT IN PERSONNEL INJURY OR EQUIPMENT DAMAGE.

If a crane is not available, the plenum may be lifted by another means, taking care to prevent deformation of the assembly during lifting. Shipping braces should be left in place until the plenum is in position.

If equipment or space restrictions prevent the use of power equipment to lift the plenum assemblies, they must be installed manually. To do this, select a single plenum assembly and disassemble it into component pieces, saving all parts and hardware. Then install the plenum on top of the equipment one piece at a time, reassembling with the same hardware. It is strongly recommended that only one assembly is disassembled at a time, so the others may be used as a reference during reassembly, and parts are not confused.

2.3 Storing

If it is necessary to store the equipment before installation, place the equipment on a true and level surface in order to reduce strain and distortion in the equipment. Cover the equipment and keep it in a clean and dry location with ample air circulation and heat to prevent condensation.

IMPORTANT

STORING THE PLENUM OR DUCT OUTDOORS IS NOT RECOMMENDED.

Section 3: Plenum Installation

⚠ WARNING

DO NOT OVER-TIGHTEN SELF-TAPPING SCREWS. IF ANY SELF TAPPING SCREWS STRIP DURING INSTALLATION, THEY MUST HAVE A NUT INSTALLED ON THE INSIDE TO SECURE THEM. THE NUT SHOULD BE INSTALLED ON THE SAME TORQUE VALUE AS THE SELF-TAPPING SCREW. FOR THIS REASON, AIR-POWERED IMPACT TOOLS ARE NOT RECOMMENDED.

ALL SCREWS MUST BE INSTALLED WITH A FLAT WASHER UNDER THE HEAD OF THE SCREW.

CONNECTIONS USING A STANDARD SCREW AND NUT MUST HAVE A FLAT WASHER UNDER THE SCREW HEAD AND BOTH FLAT- AND LOCK-WASHERS UNDER THE NUT. IF USING KEPS NUTS, THE FLAT- AND LOCK-WASHERS SHOULD BE OMITTED FROM THE NUT.

Table 2. Bolt Torque Values for All Hardware Connections

Bolt Size in (mm)	0.25 (6.35)	0.31 (7.87)	0.38 (9.65)
Bolt Material	Torque in Foot-Pounds (N-m)		
High Strength Steel	5 (6.78)	12 (16.27)	20 (27.12)
Silicon Bronze	5 (6.78)	10 (13.56)	15 (20.34)
Stainless Steel	5 (6.78)	12 (16.27)	20 (27.12)

NOTICE

SELF-TAPPING SCREWS ARE USED FOR ALL "BLIND" INSTALLATIONS, WHERE THE BACK SIDE OF THE JOINT IS NOT EASILY ACCESSED. ANY JOINTS WHERE THE SHAFT OF THE SCREW IS EASILY ACCESSIBLE ARE SECURED WITH STANDARD SCREWS AND A NUT ON THE BACK SIDE.

3.1 VacClad only

Step 1

Ensure all shipping splits of the switchgear are installed, coupled, and bolts are torqued.

Step 2

Installation of Plenum Spacer Plates.

- A Remove the existing hardware from the rear of the front module roof sheet and place two plenum spacer plates over the holes where the hardware was removed (See **Figure 4**). Set aside the hardware for use later to install the plenum. Repeat this operation for all front modules in the lineup.

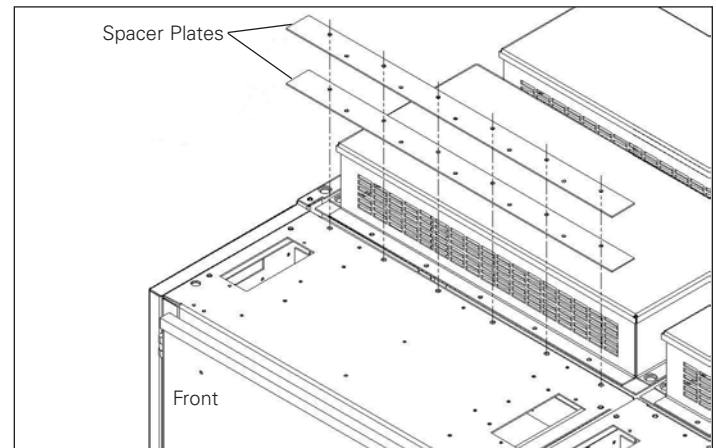

Figure 4. Installation of the Front Module Spacer Plates

- B. For the 96-inch deep switchgear designs only: Remove the existing hardware from the rear of the rear module roof sheet. Where the hardware was removed, place a single plenum spacer plate over the holes where the hardware was removed and replace hardware (See **Figure 5**). Repeat this operation for all rear modules in the lineup.

For the 108-inch deep switchgear designs only: The arc spacer plate was installed by the factory and no action is required at this time (any spare plenum spacer plates can be discarded).

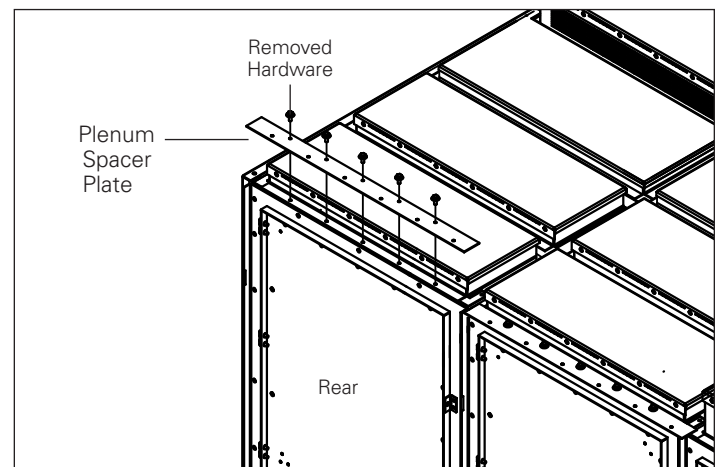

Figure 5. Installation of Rear Module Plates (96-Inch Deep Switchgear Only)

Step 3

Install the first plenum section.

Note: At least 2 sections in every lineup will have an exhaust duct exiting from the side of the plenum. These sections can be identified either because they have an exhaust duct collar already installed, or there is a square opening for the duct collar. Identify these sections and install them first, for ease of assembly. If possible, install the duct collar before moving the plenum into position (refer to section 4 for instructions). If this is not possible, first install the plenum sections which have ducts, then lift the duct collar inside the plenum and install it before installing additional plenum sections. **The duct collars can ONLY be installed from the INSIDE of the plenum, so it is critical that they are not left until the end.**

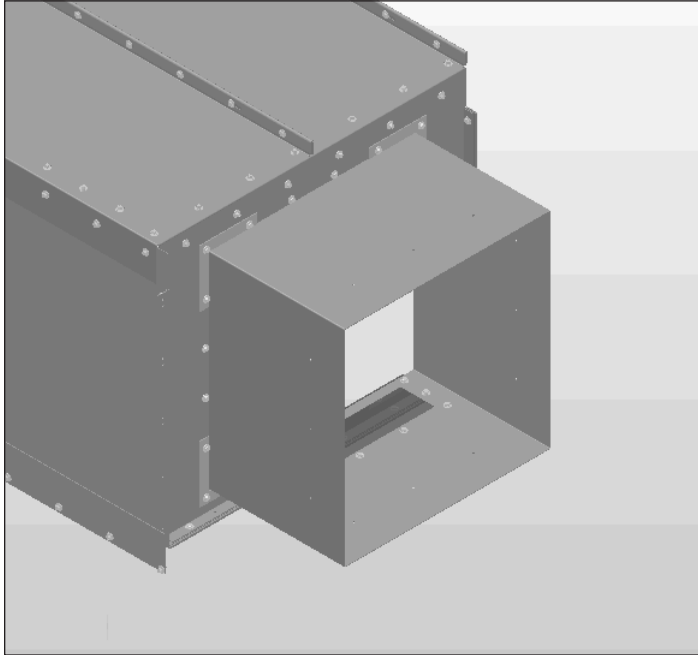

Figure 6. Plenum Section with Exhaust Duct Collar

A Use an overhead crane to lift the first plenum group onto the switchgear. Install washer plates onto the flanges around the entire perimeter of the plenum. (See **Figure 7**).

Table 3. Washer Plates

Description	Style number
36" exhaust wall washer plate	69C4245H01
Left hand / right hand exhaust wall washer plate	69C4245H02
Plenum extension end washer plate	69C4367H02
Plenum extension intermediate washer plate	69C4367H03
Plenum extension rear washer plate	69C4367H04

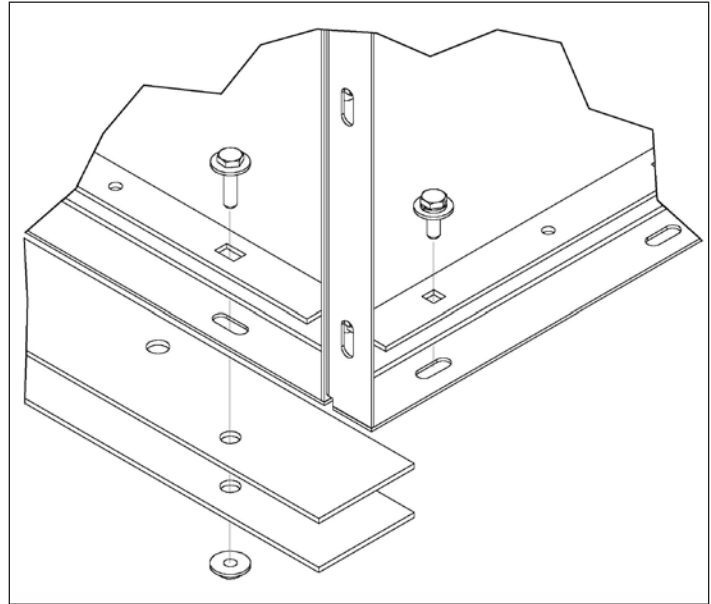

Figure 7. Installing Washer Plates

B Ensuring that all washer plates are in place, Loosely attach the plenum to the gear with ¼"-20 self tapping screws. For ease of assembly, make snug but do not torque screws until all plenum groups are attached and connected; this will allow parts to shift and eliminate hole-alignment problems.

Step 4:

Installing additional plenum sections

A Lift and place the next plenum section adjacent to the one already installed. ENSURE WASHER PLATES ARE IN PLACE. Fasten the plenum to the top of the gear with ¼-20 self-tapping screws and snug but do not torque all fasteners.

B Install vertical seam covers (69C4080H01) over adjoining vertical flanges, using ¼-20 standard screws and nuts. (See **Figure 8**).

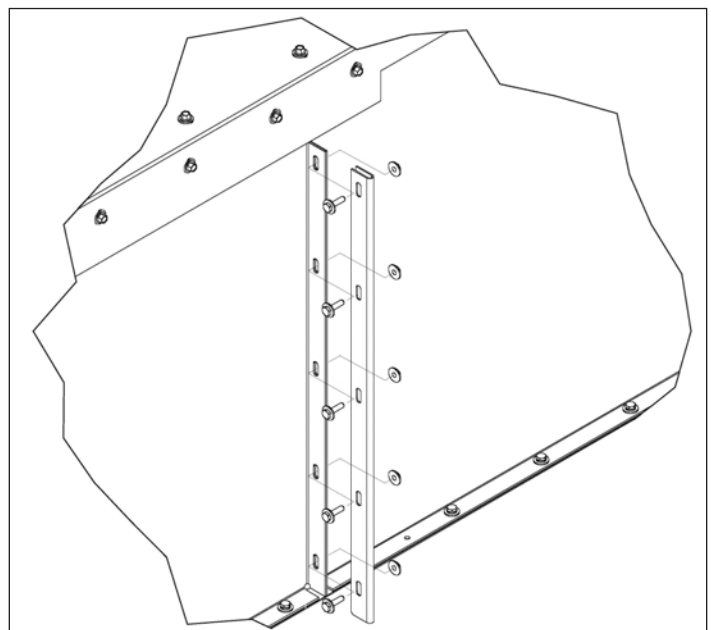

Figure 8. Installing vertical seam covers

C Install a roof seam cover (69C4311H01) over the roof flanges using 5/16-18 standard screws and nuts. (See **Figure 9**)

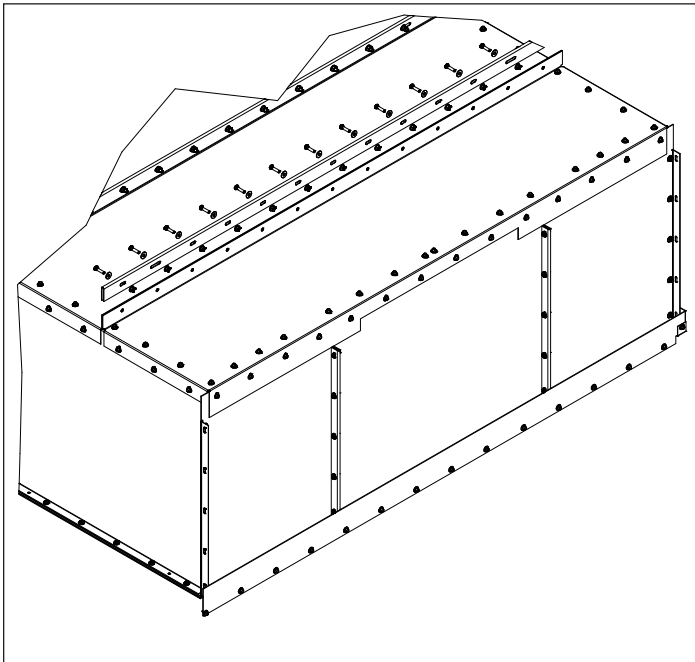

Figure 9. Installing Roof Seam Covers

D Once all plenum sections are installed on top of the lineup, torque all fasteners per Table 2.

Step 5:

Plenum sections with exhaust ducts

Plenum sections with exhaust ducts have an access port to allow the screws directly beneath the collar to be installed. After securing all the plenum sections and before proceeding to install the gas deflectors, ensure the screws behind this access port are torqued, and then install the access cover (68B4280H01) in the collar using ¼-20 standard screws with nuts.

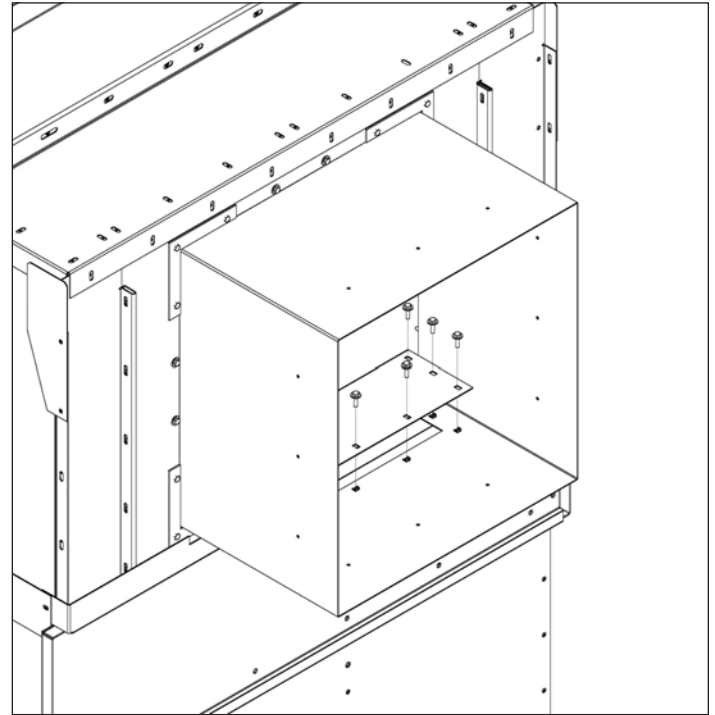

Figure 10. Duct Collar Access Plate Installation

Step 6

Once all plenum groups are attached to the gear and to one another via seam covers, torque all hardware per Table 2.

Step 7

Install gas deflectors

Note: All seam connections in the plenum must be covered by seam covers or gas deflectors. Failure to install these covers and deflectors will void compliance with ANSI/IEEE CS37.20.7. Please contact the factory with any questions.

Mounting the Z Gas Deflector: 96-inch switchgear and bus transition to AMPGARD

A. Remove the three self-tapping screws from the top vertical face of the rear module.

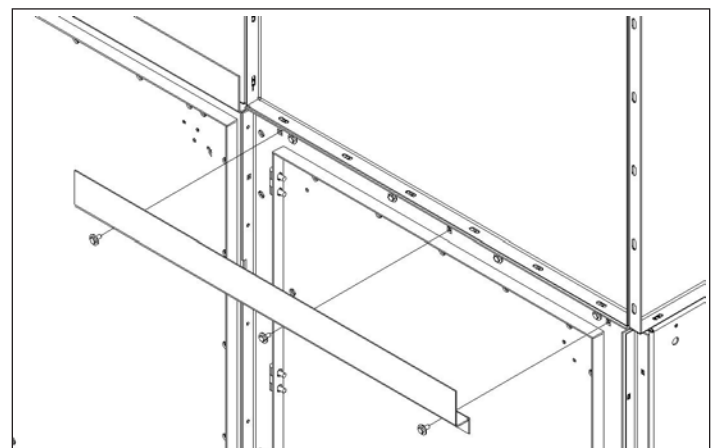

Figure 11. Installation of the Z Gas Deflector

- B. Mount the Z gas deflector (69C4232H01) to the top of the rear module and replace the self-tapping screws removed above (see **Figure 11**).
- C. Repeat A and B for each rear vertical section.

Note: When a plenum section with either one or two duct collars is installed, the Z gas deflectors will be replaced with a special notched piece to accommodate the bottom of the duct collar (69C4109H01 for single duct or 69C4109H02 for double duct). Once the Z gas deflector with a notch is installed, secure a duct cover (694110H01) to the Z gas deflector using self tapping screws (See **Figure 12**).

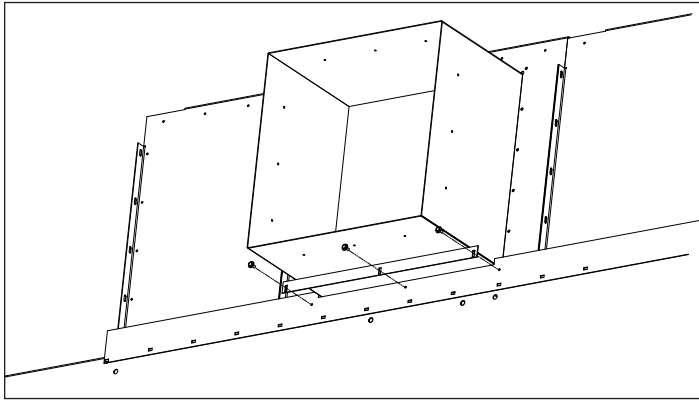

Figure 12. Z Gas Deflector with Duct Collar.

- D. Hold the front to rear gas deflector (69C4107H01 and H02) in place against the left hand side sheet of the lineup such that the bent portion overlaps on the outside of the Z gas deflector mounted in step 5.1. Line up a slot in both ends of the front to rear gas deflector and loosely insert a self tapping screw in each (See **Figure 13**).

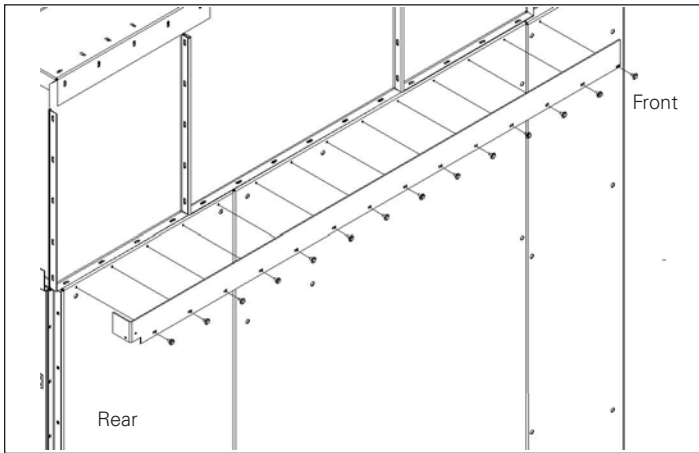

Figure 13. Installation of the Front to Rear Deflector (96-Inch Deep Switchgear)

- E. Move the front to rear gas deflector towards the front of the unit until the front to rear gas deflector mates with the Z gas deflector. Tighten two self tapping screws, then insert and tighten the remaining self tapping screws.

Note: When a plenum section with either one or two duct collars is installed on the side wall, the front to rear gas deflector will be replaced with a special notched piece to accommodate the bottom of the duct collar (69C4106H02 or 69C4107H02 for a single duct and 69C4106H03 or 69C4107H03 for double duct). Once the front to rear deflector with a notch is installed, a duct cover 694110H01 is secured to the Z gas deflector using the self tapping screws (See **Figure 12**).

- F. Line up the gas deflector filler plate (68B4057H01 or H02) with the holes in the bend on the rear of the front to rear gas deflector. Insert and tighten two self tapping screws (See **Figure 14**).

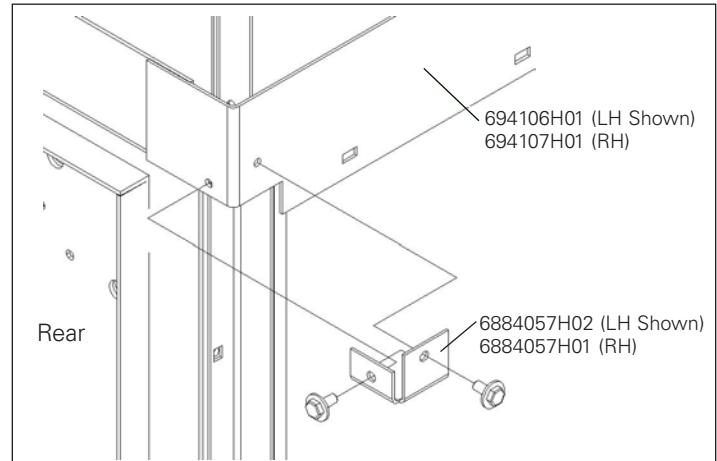

Figure 14. Installation of the Gas Deflector Filler Plates (Left-Hand Shown)

- G. Repeat D-F for the other side.

Mounting the Front to Rear Gas Deflector: (108-Inch and 120 inch Deep Switchgear)

- A. Hold the front to rear gas deflector 69C4134H01 in place against the side of the lineup. Line up a slot on both ends of the front to rear gas deflector and loosely insert a self tapping screw in each end.
- B. Tighten two self tapping screws, then insert and tighten the remaining self tapping screws (See **Figure 15**).

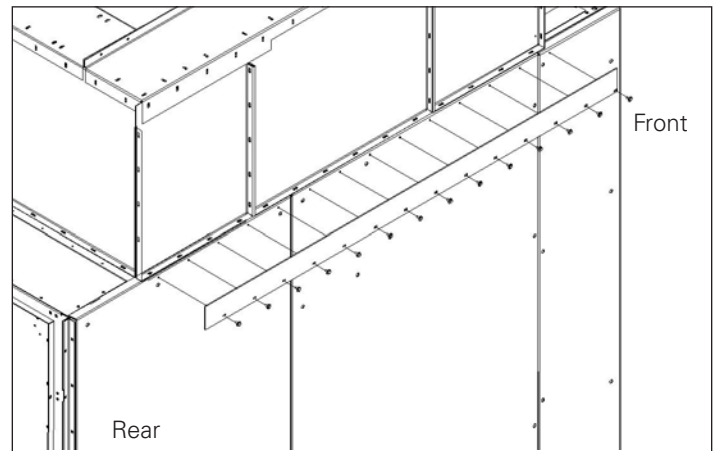

Figure 15. Installation of the Front to Rear Gas Deflector (108-Inch Deep Switchgear).

- C. Repeat H and I on the other side of the switchgear.

Note: When a plenum section with either one or two duct collars is installed on the side wall, the front to rear gas deflector will be replaced with a special notched piece to accommodate the bottom of the duct collar (69C4134H02 for a single duct or 69C4134H03 for double duct). Once the front to rear deflector with a notch is installed, a duct cover 69C4110H01 is secured to the Z gas deflector using the self tapping screws (See **Figure 12**).

- D. On the front and back of the plenum, install seam and gas deflectors (69C4344H01). (See **Figure 16**).

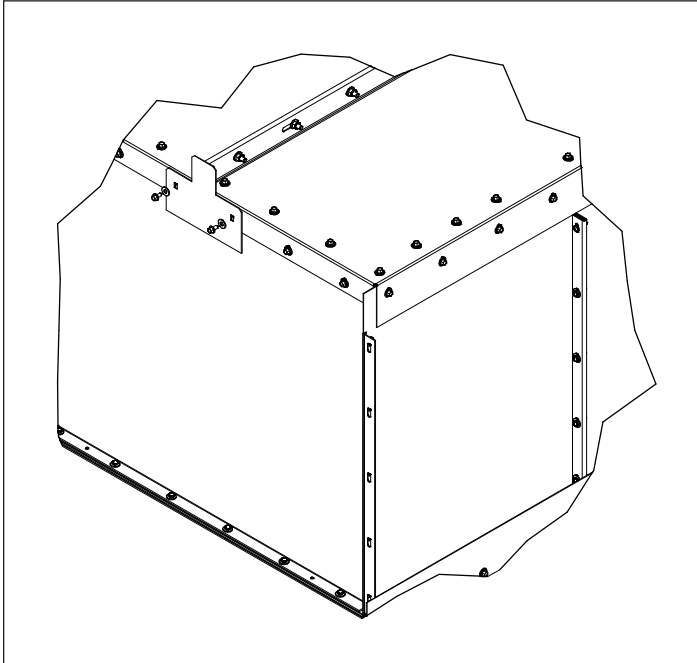

Figure 16. Seam and Gas Deflectors

At each top corner, install corner gas deflector. Attach as shown in **Figure 17**.

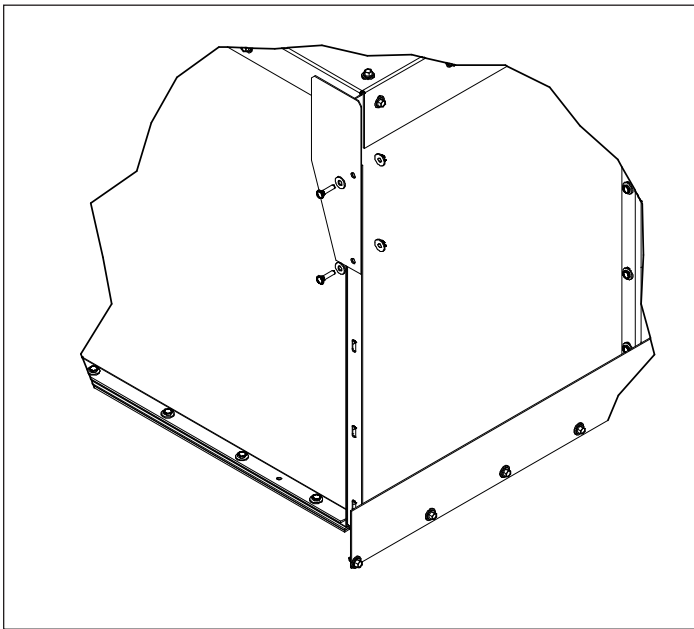

Figure 17. Corner Gas Deflectors

Step 8:
 Installation complete

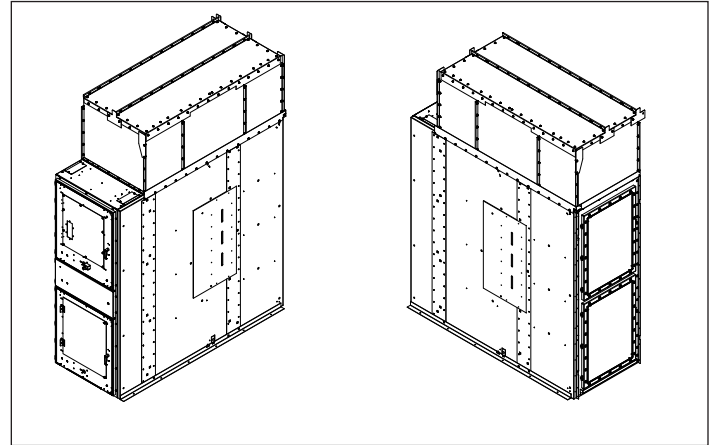

Figure 18. Standard 96" deep VacClad structure with plenum attached

3.2 AMPGARD only

Lineups of AMPGARD are only 50" deep, however the basic structure and design of the plenum is the same as VacClad in a shorter depth. Plenum installation on AMPGARD is similar to installation on VacClad, but there are some differences. Read and follow these instructions completely.

Step 1: Install Cableways

AMPGARD top-entry load and low-voltage cables are routed through the plenum, via cableways. These cableways are shipped pre-assembled, but must be installed on top of the equipment before the plenums.

A Install Low voltage (LV) cableways

LV cable cableways (87C1132G01) are installed on all AMPGARD sections. Before starting, note that the cableway has a TOP and a BOTTOM. The top end has square holes with cage nuts installed. The bottom has only round clearance holes for 1/4" fasteners. (See **Figure 19**).

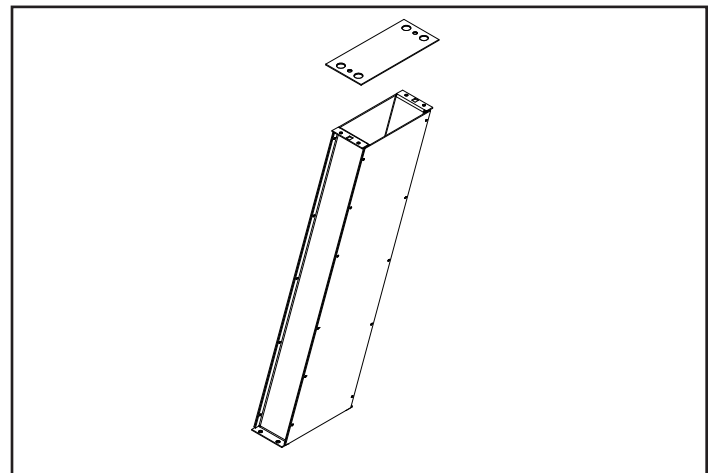

Figure 19. The LV cableway

Position the LV cableway with the bottom over the low-voltage conduit opening on top of the equipment. If there is a cover plate over the opening, remove it first. The cableway should slant AWAY from the front of the equipment. Secure it in place with ¼" self-tapping screws. (See **Figure 20**).

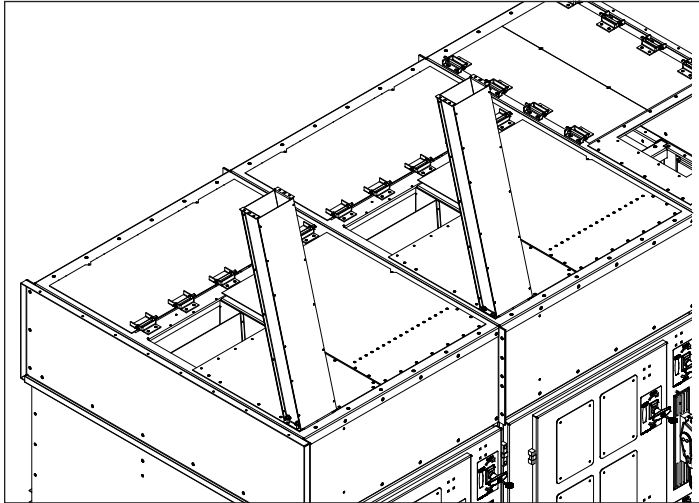

Figure 20. Installing LV cableway

B Install Medium Voltage (MV) cableways

If the equipment has top-entry cabling, Medium-voltage (MV) cableways for the load (87C1132G02) and incoming line (87C1132G03) must also be installed. Identify the TOP and BOTTOM of these cableways by locating the end with square holes and cage nuts installed. This end is the TOP. (See **Figure 21**).

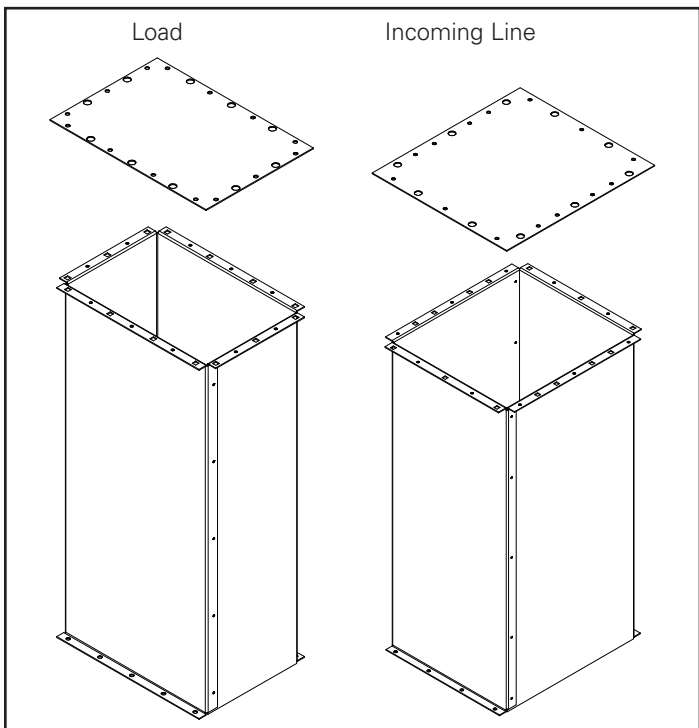

Figure 21. MV Cableways

Position each MV cableway over the matching opening and align the mounting holes. Secure the cableway in place with ¼" self-tapping screws. (See **Figure 22**).

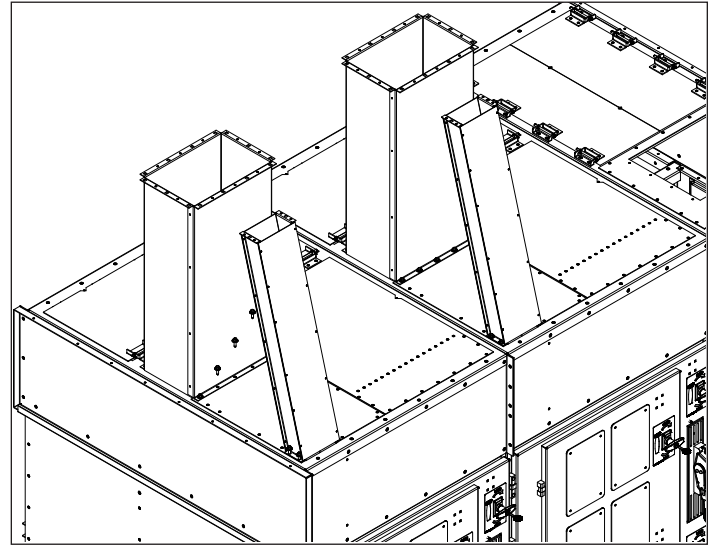

Figure 22. Installing MV Cableways

Step 2: Install first plenum section

⚠ WARNING

DO NOT OVER-TIGHTEN SELF-TAPPING SCREWS. IF ANY SELF TAPPING SCREWS STRIP DURING INSTALLATION, THEY MUST HAVE A NUT INSTALLED ON THE INSIDE TO SECURE THEM. WITH THE NUT SHOULD BE INSTALLED TO THE SAME TORQUE VALUE AS THE SELF-TAPPING SCREW. FOR THIS REASON, AIR-POWERED IMPACT TOOLS ARE NOT RECOMMENDED:

Before installing the plenum onto a section of AMPGARD, the cableways for that section must already be installed. If this has not already been done, review section 3.2, step 1.

Note: Sections which have an exhaust duct exiting from the plenum can be identified by the square opening for the duct collar in one or more panels. Identify these sections and install them first, for ease of assembly. If possible, install the duct collar before moving the plenum into position (refer to section 4 for instructions). If this is not possible, first install the plenum sections which have ducts, then lift the duct collar inside the plenum and install it immediately, before installing additional plenum sections. The duct collars can ONLY be installed from the INSIDE of the plenum, so it is critical that they are not left for the end.

A Following the guidelines in 2.2, lift the first plenum section into place on top of the equipment. Install washer plates onto the flanges around the entire perimeter of the plenum. (See **Figure 23**).

Table 4. Washer Plates

Description	Style number
washer plate 24" wide	87C1129H01
washer plate 28" wide	87C1129H04
washer plate 36" wide	87C1129H02
washer plate 40" wide	87C1129H03
washer plate 6" wide	87C1129H05
washer plate transition	87C1129H06

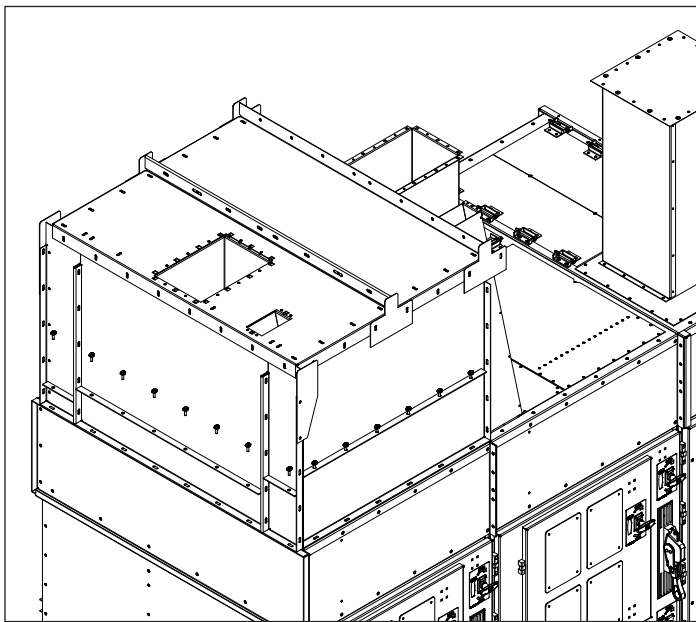

Figure 23. Installing AMPGARD Washer Plates

- B Ensuring that all washer plates are in place, Loosely attach the plenum to the gear with ¼"-20 self tapping screws. For ease of assembly, make snug but do not torque screws until all plenum groups are attached and connected; this will allow parts to shift and eliminate hole-alignment problems.
- C The 4 lifting eyes attached to the roof of the plenum may now be removed if desired.

Step 3: Install additional plenum sections

- A Lift and place the next plenum section adjacent to the one already installed. ENSURE WASHER PLATES ARE IN PLACE. Fasten the plenum to the top of the gear with ¼-20 self-tapping screws and snug but do not torque all fasteners.
- B Install vertical seam covers (87C1093H02) over adjoining vertical flanges, using ¼-20 standard screws and nuts. (See **Figure 24**).

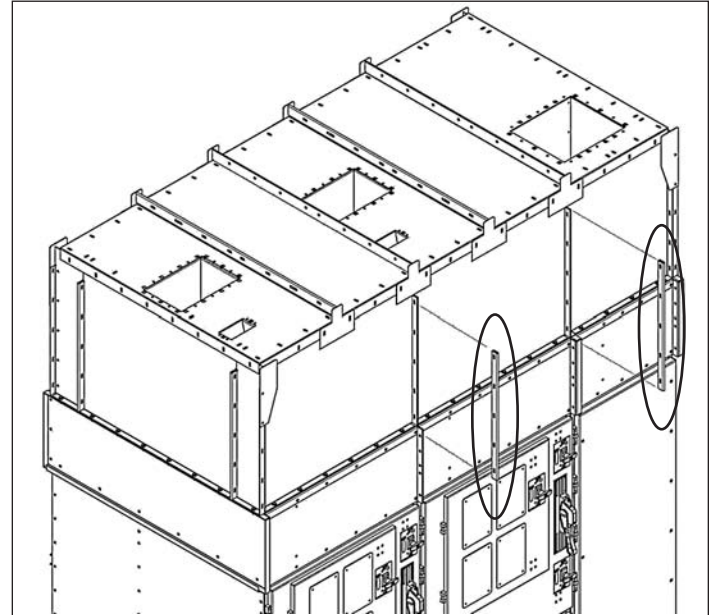

Figure 24. Installing Vertical Seam Covers

- C Install a horizontal seam cover (87C1093H01) over all roof flanges using 5/16-18 standard bolts and nuts. (See **Figure 25**).

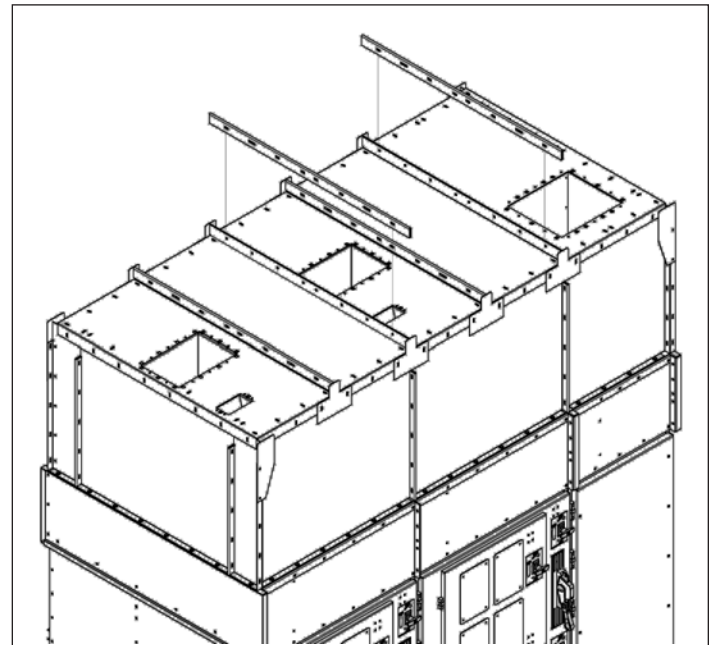

Figure 25. Installing Horizontal Covers

- D Once all plenum groups are attached to the gear and to one another via seam covers, torque all hardware per Table 2.

Step 4: Dual-exhaust manifold

In AMPGARD lineups configured with both exhaust ducts exiting at one end of the lineup, the dual-exhaust manifold must be installed. The manifold cannot be attached to a top-entry incoming line section. For lineups that do not have a dual-exhaust manifold, this step may be skipped.

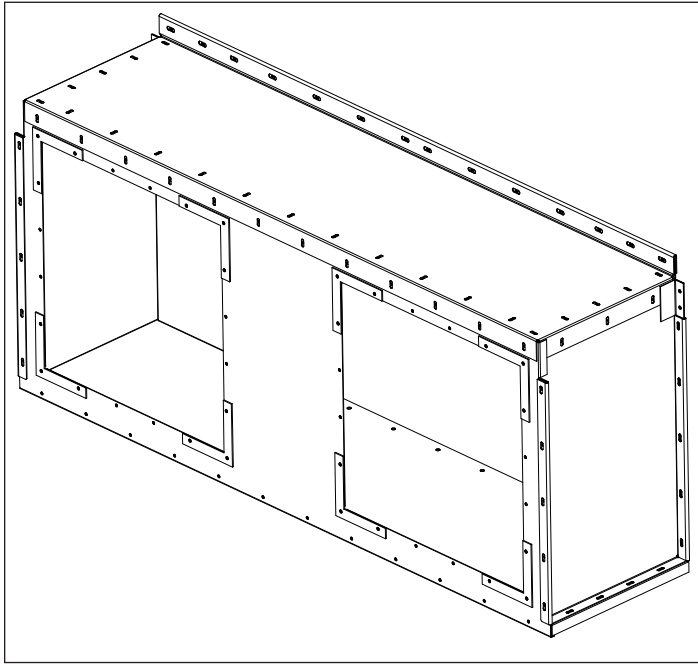

Figure 26. Dual-exhaust Manifold

- A Install the plenum section at the manifold-end of the lineup first, per Step 3.
- B If possible, first install the duct collars into the exhaust manifold per section 4.2.
- C Lift the exhaust manifold assembly into position at the end of the lineup, either by using slings or by attaching lifting eyes removed from the already-installed plenum section.
- D Align the holes along the bottom edge of the manifold with the mating holes on the equipment. Loosely install ¼" self-tapping screws along the bottom to hold it in position.

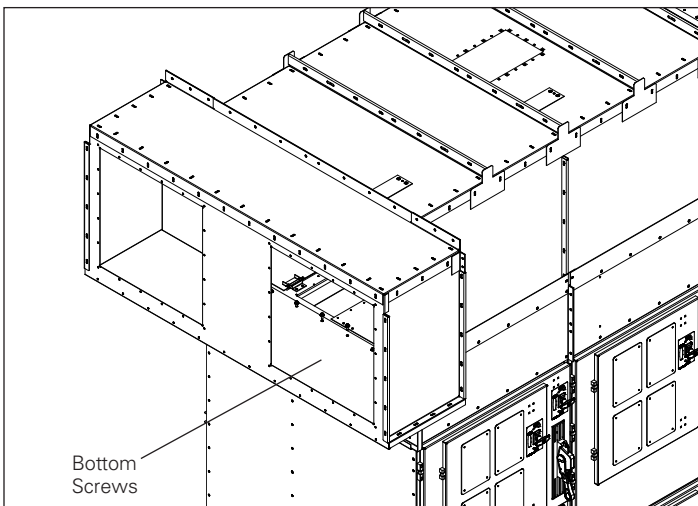

Figure 27. Installing Dual-exhaust Manifold

Duct and Plenum Installation for Eaton 5/15 kV Type VacClad-W Arc Resistant Metal-Clad Switchgear and AMPGARD Arc Resistant Motor Control Centers

- E Bring the top of the manifold toward the roof of the plenum, ensuring that the vertical seams of the plenum and the manifold come into alignment. Use ¼" self-tapping screws to hold these flanges in place.

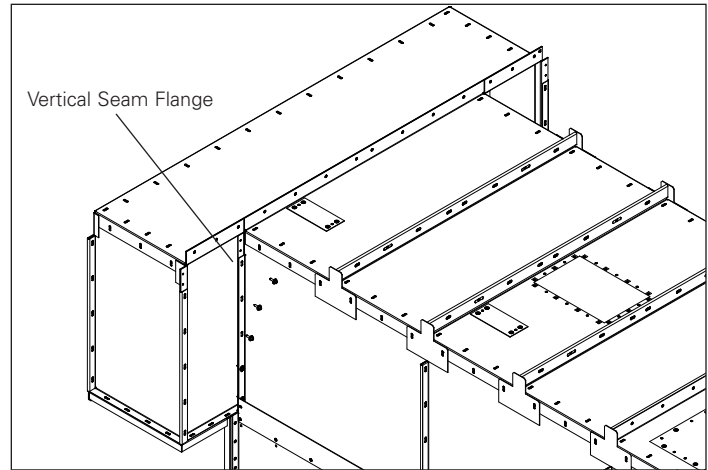

Figure 28. Manifold vertical seams

- F Ensure that the roof flange of the plenum lines up with the roof flange of the manifold. Install the long roof seam cover (87C1093H06) over the flanges and install 5/16" bolts in all holes to secure the roof.
- G Returning to the two vertical seams, install ¼" self-tapping screws in any empty holes and torque all screws per Table 2.
- H Install 4 additional baffles (87C1093H08) in the manifold corners (2 shown).

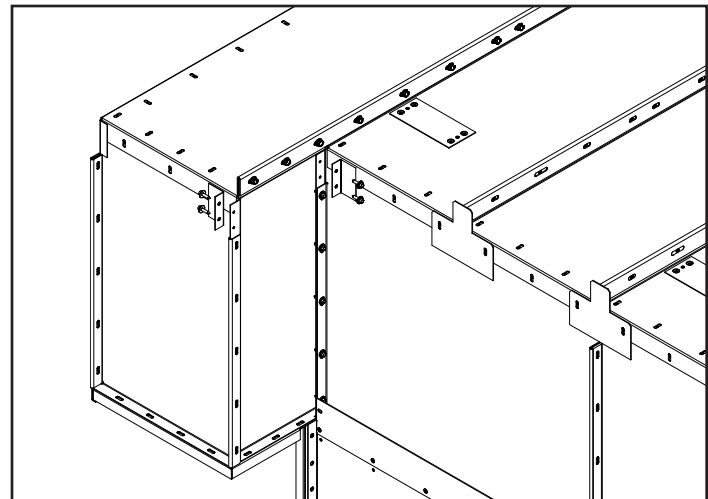

Figure 29. Duct Manifold Baffle Installation

- I Torque the screws in the bottom edge of the manifold.
- J Disconnect any lifting devices from the manifold.

IMPORTANT

SEAM CONNECTIONS IN THE PLENUM MUST BE COVERED BY SEAM COVERS OR GAS DEFLECTORS WHERE SPECIFIED. FAILURE TO INSTALL THESE COVERS AND DEFLECTORS WITHOUT PRIOR APPROVAL FROM EATON ENGINEERING WILL COMPROMISE THE ARC RESISTANT RATING OF THE ENTIRE LINEUP.

Step 5: Secure cableway tops

After the plenums are fully secured, the tops of the cableways must be anchored to the plenum roof. This requires access to the top of the plenum. Align each cableway hole pattern with the holes in the plenum roof, and secure it in place using 1/4" self-tapping screws as shown in **Figure 30**.

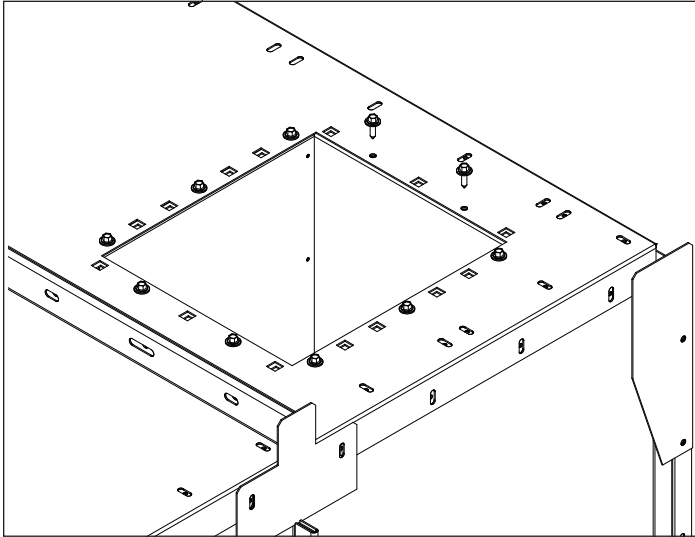

Figure 30. Securing cableways

Step 6: Install cableway covers

Each of the cableways are provided with covers for the top opening. The covers are secured to the plenum roof using 1/4" standard bolts which are threaded into the cage nuts. Only install bolts into the small holes of the covers – the large holes are for clearance around the existing screws only.

IMPORTANT

DO NOT USE AN IMPACT-TYPE DRIVER TO INSTALL THESE SCREWS! IMPACT TOOLS TEND TO KNOCK THE CAGE NUTS OUT OF THEIR HOLE. ANY DISPLACED NUTS MUST BE REPLACED, WHICH REQUIRES GOING INSIDE THE PLENUM – USUALLY VERY DIFFICULT AT THIS POINT.

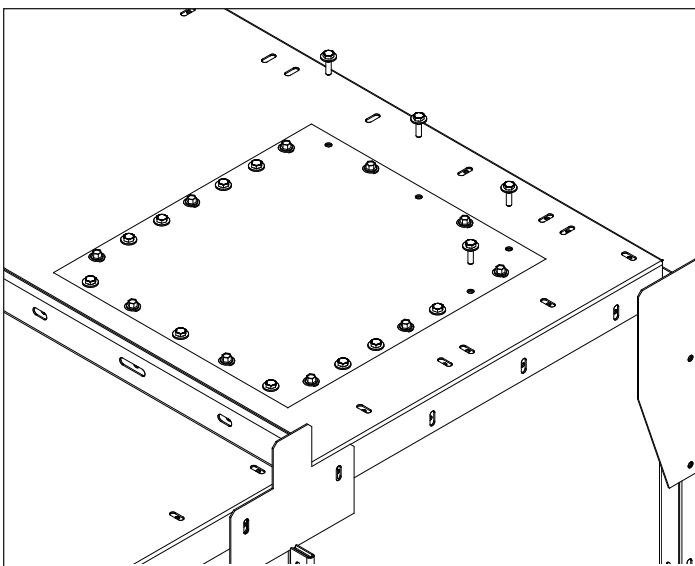

Figure 31. Installing Cableway Covers

Step 7: Install gas deflectors

Table 5. Gas Deflector Parts

Description	Style number
24" wide gas deflector	87C1128H01
36" wide gas deflector	87C1128H02
Gas deflector splice plate	87C1128H03
End gas deflector	87C1128H04
Gas deflector, 30" duct	87C1128H07
Gas deflector end, duct	87C1128H08
Gas deflector, 72" duct	87C1128H09

A Remove the bolts along the front and rear of the entire lineup as shown in **Figure 32**. Retain all hardware for reassembly.

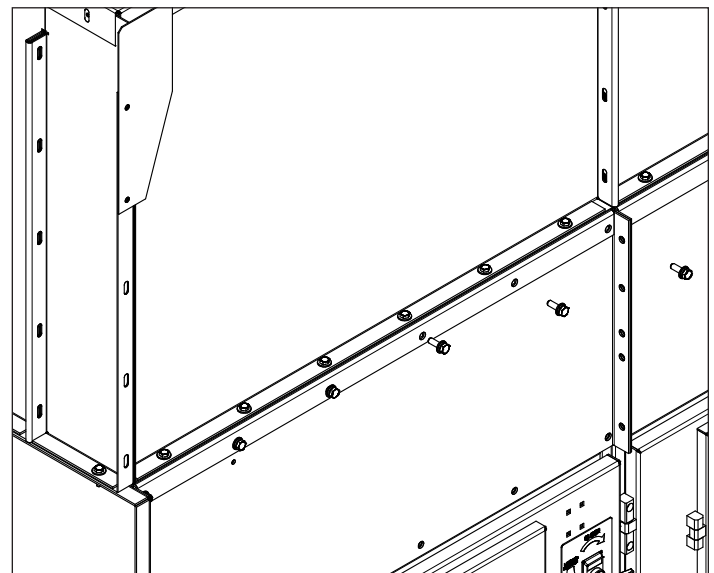

Figure 32. Preparing to Install Front / Rear Gas Deflectors

B Put a front / rear gas deflector in place (87C1128H02) and secure it with the retained hardware as shown in **Figure 33**.

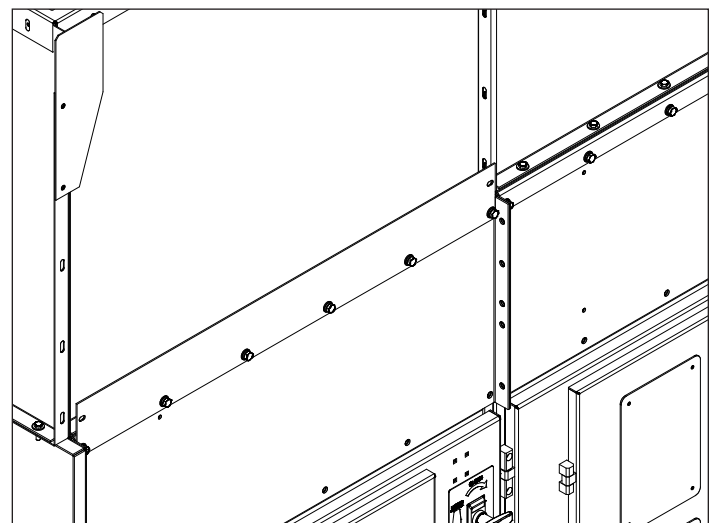

Figure 33. Installing front / rear gas deflectors

- C Between adjacent sections, the front / rear gas deflectors must be joined together using splice plates (87C1128H03). Insert the splice plate behind the installed gas deflectors as shown in **Figure 34** and secure using 1/4" self-tapping screws.

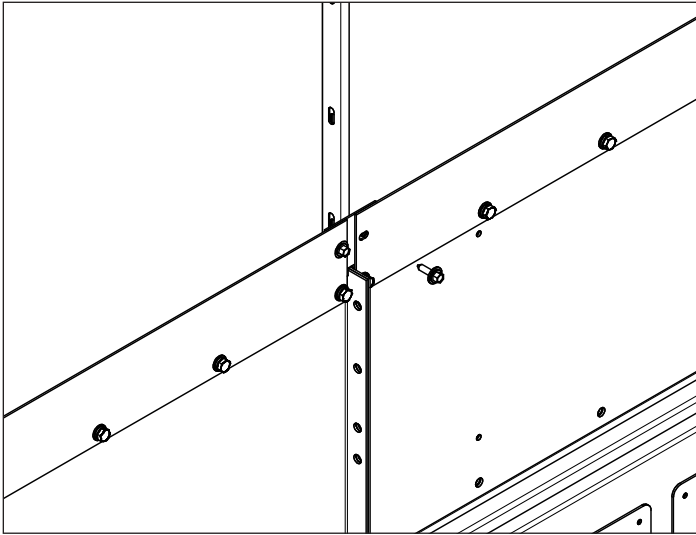

Figure 34. Gas deflector splice plates

- D For any AMPGARD structures on the end of a lineup, an end gas deflector (87C1128H04) must be installed. The deflector is positioned with its bottom flange beneath the flanges of the plenum, and with the side flanges inboard of the adjacent front / rear deflectors. (See **Figure 35**).

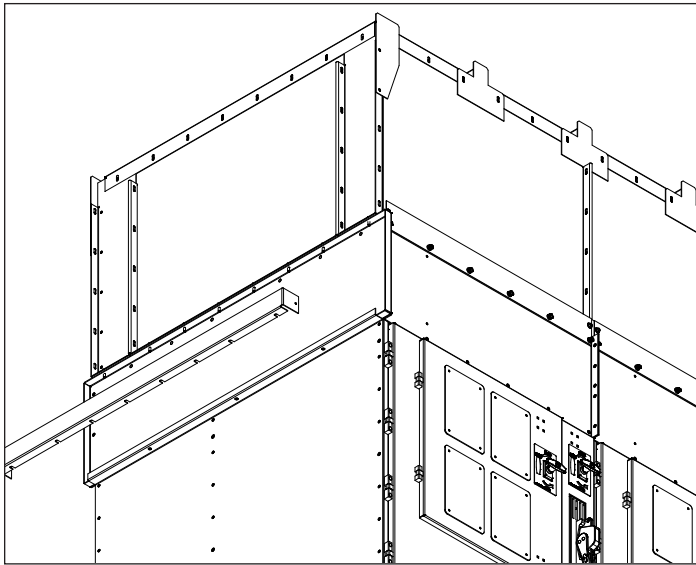

Figure 35. Installing End Gas Deflector

- E Secure the end gas deflector by installing 1/4" nuts over the protruding screws along the underside of the deflector (see **Figure 36**).
- F Ensure the ends of the gas deflector are slid behind the front and rear gas deflectors, and secure in place with 1/4" self-tapping screws. (see **Figure 36**).

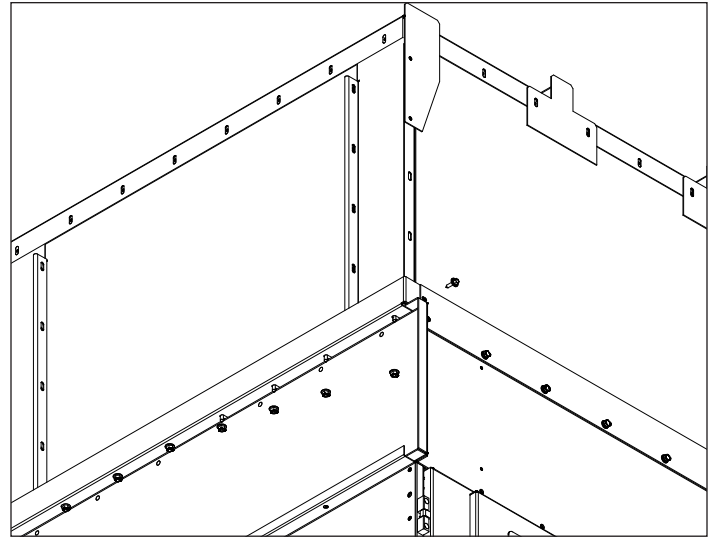

Figure 36. Connecting End Gas Deflectors to Front and Rear

3.3 VacClad close-coupled to AMPGARD

In an VacClad lineup that is close-coupled to AMPGARD, a 36" wide bus transition section is required between the two lineups. The plenum over this transition section extends to both the front and rear of the VacClad gear (except on 120" deep lineups), and is designed to connect the VacClad plenum volume to the AMPGARD plenum. See figures 37 through 39 for details.

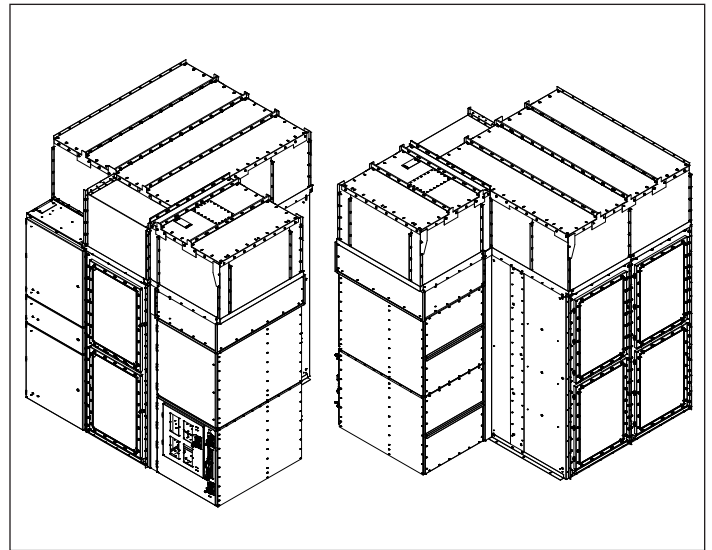

Figure 37. 96" Deep VacClad, Front Aligned AMPGARD.

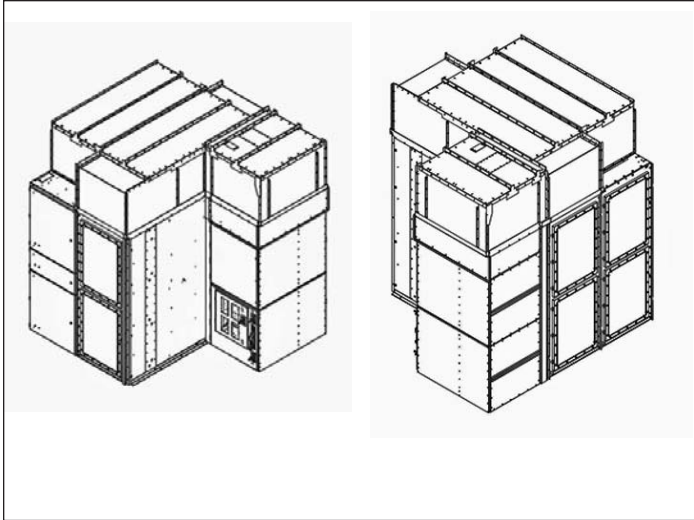

Figure 38. 108" Deep VacClad, Rear Aligned AMPGARD

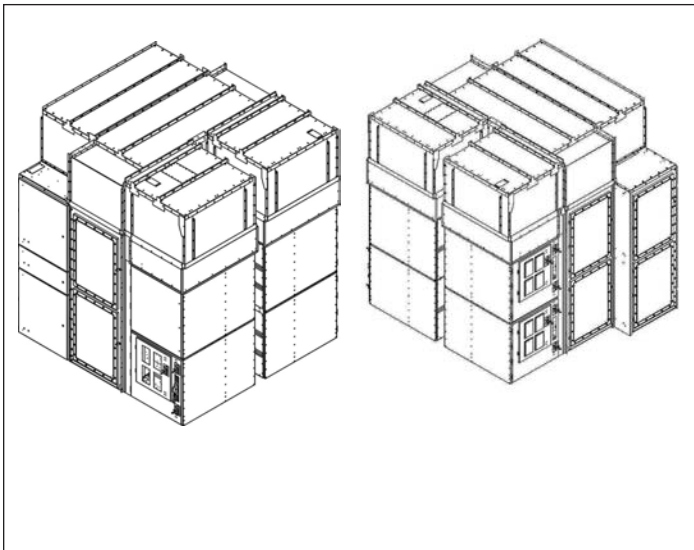

Figure 39. 120" Deep VacClad, Dual AMPGARD

Step 1: Install VacClad and AMPGARD lineups

- A Following the instructions for each type of equipment, install the entire lineup.
- B Make all splice connections and replace any covers that were removed.
- C Make the close-coupling connection between VacClad and AMPGARD using 12 x 3/8" bolts.

CAUTION

BEFORE INSTALLING HARDWARE, ENSURE THAT THE VACCLAD AND AMPGARD LINEUPS ARE CAREFULLY ALIGNED AND FLUSH. DO NOT USE THE CLOSE-COUPPING BOLTS TO DRAW THE STRUCTURES TOGETHER IF THEY ARE MISALIGNED.

- D Secure the lineup to the floor.

Step 2: Install VacClad plenums

Following the instructions in section 3.1, install the VacClad plenum

Step 3: Install AMPGARD and filler plenum

Following the instructions in section 3.2, install the AMPGARD plenums. The section of AMPGARD plenum which abuts the VacClad lineup should include a portion which matches the 4" wide filler section between the two lineups (see **Figure 40**).

Step 4: Install VacClad deflectors per 3.1

Step 5: Install AMPGARD gas deflectors per 3.2

Step 6: Install case coupling gas deflectors

Following the table below, install the correct transition gas deflectors between the VacClad and AMPGARD lineups using ¼" self tapping screws as shown in Figure 41.

Table 6. Transition Gas Deflectors

Close-coupling configuration	Gas deflector location on lineup	AMPGARD to the right of VacClad (viewed from front)	AMPGARD to the left of VacClad (viewed from front)
Front aligned	front	68B4196H01	68B4196H02
	rear	68B4203H01	68B4204H01
Rear aligned	front	68B4196H02	68B4196H01
	rear	68B4204H01	68B4203H01
"Dual AMPGARD lineups (one front and one rear aligned)"	front (front of front lineup)	68B4196H01	68B4196H02
	rear (front of rear lineup)	68B4196H02	68B4196H01

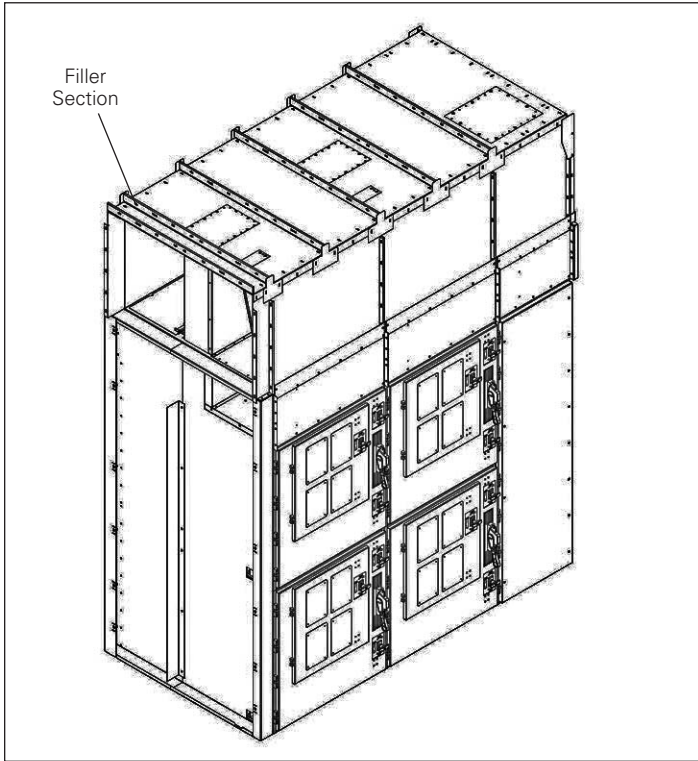

Figure 40. AMPGARD Plenum with Filler Section

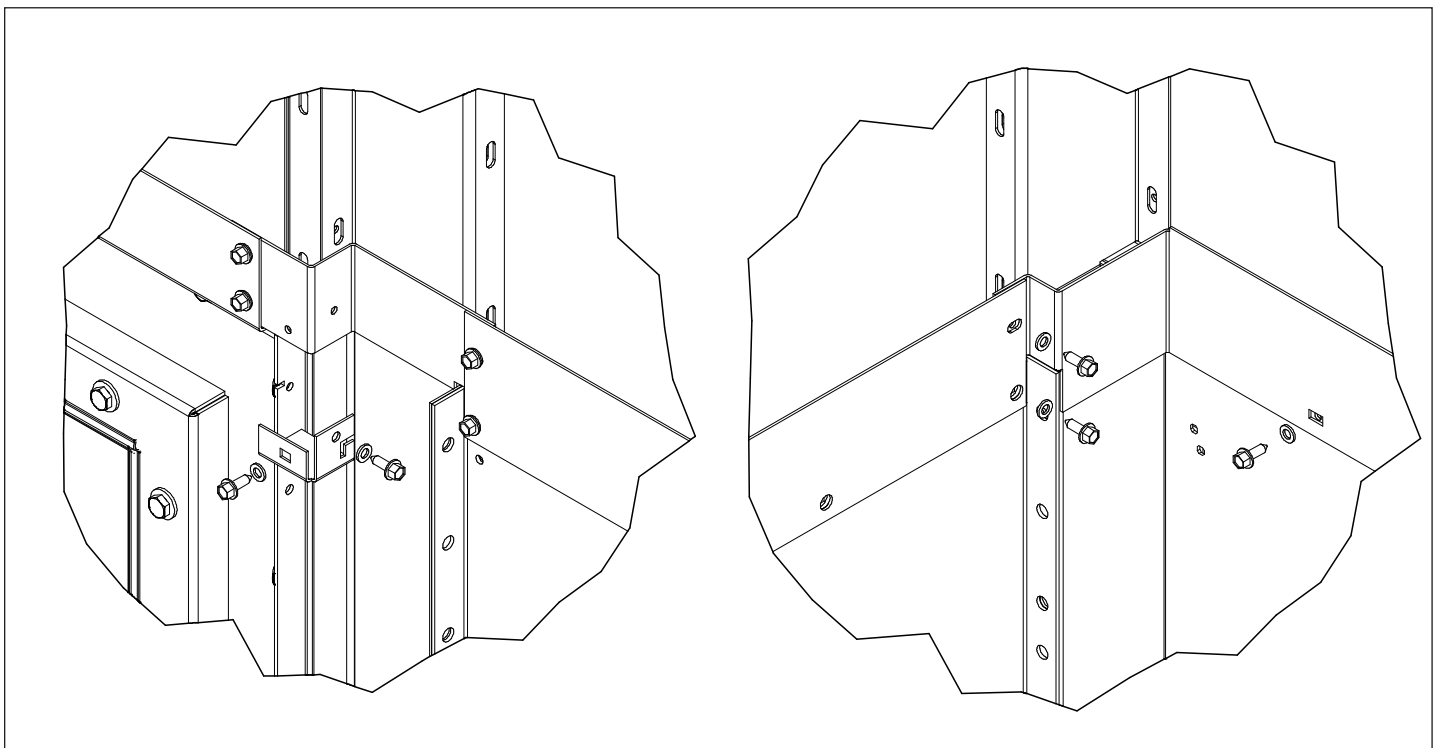

Figure 41. Close Coupling Gas Deflectors

Section 4: Duct Installation

4.1 Safety areas around duct exit

See Figures 42 - 45 for the minimum Arc Exhaust Danger area around the duct exit. The area shown in this figure must be secured against ingress to prevent injury due to arc exhaust.

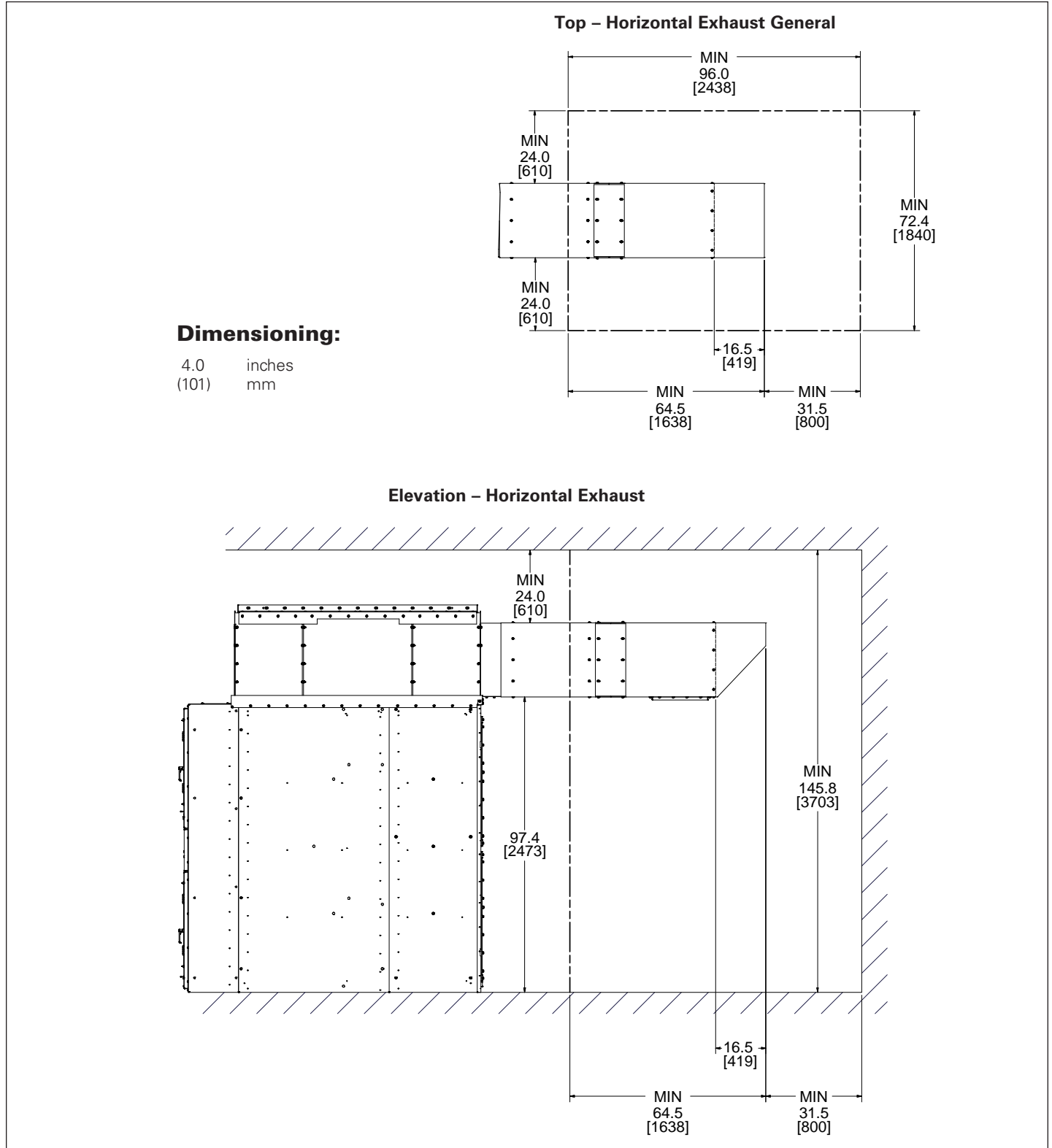
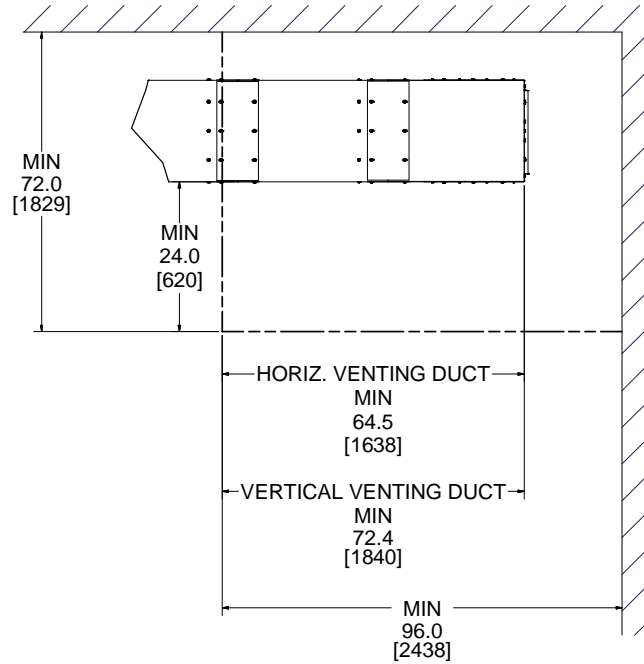

Figure 42. Exhaust Duct Safety Areas

Top - Horizontal or Vertical Exhaust Indoor



Dimensioning:

4.0 inches
 (101) mm

Elevation - Vertical Exhaust

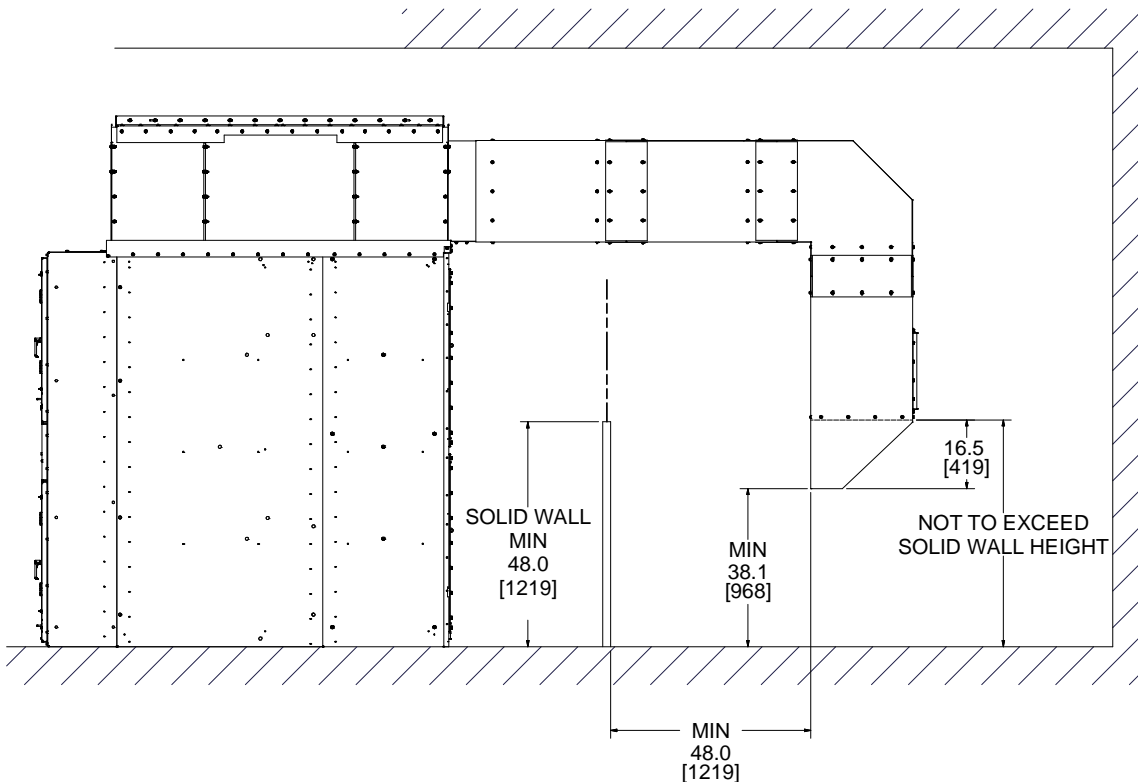

Figure 43. Exhaust Duct Safety Areas (Continued)

4.2. Duct Collar installation

If a section of plenum has the square opening for a duct collar, but there is no collar installed, this must be done before any duct can be installed. This can be done on the ground or after the plenum section is installed on top of the equipment. If the duct collar will extend through a wall, the plenum section must be installed first, then the collar inserted from inside via the top of the adjacent section.

Step 1

Insert duct collar into plenum.

Lift a duct collar into position, inserting it through the opening of a plenum wall from the inside.

⚠ WARNING

THE DUCT COLLAR MUST BE INSTALLED FROM THE INSIDE OF THE PLENUM AS SHOWN. IF IT IS ATTACHED TO THE OUTSIDE OF THE PLENUM, THE ARC RESISTANT RATING OF THE LINEUP WILL BE INVALIDATED!

Step 2

Install Hardware

Fasten the duct collar in position using 1/4" standard screws with nuts. Screws should be inserted from the outside of the plenum, with nuts located inside the plenum (See **Figure 44**).

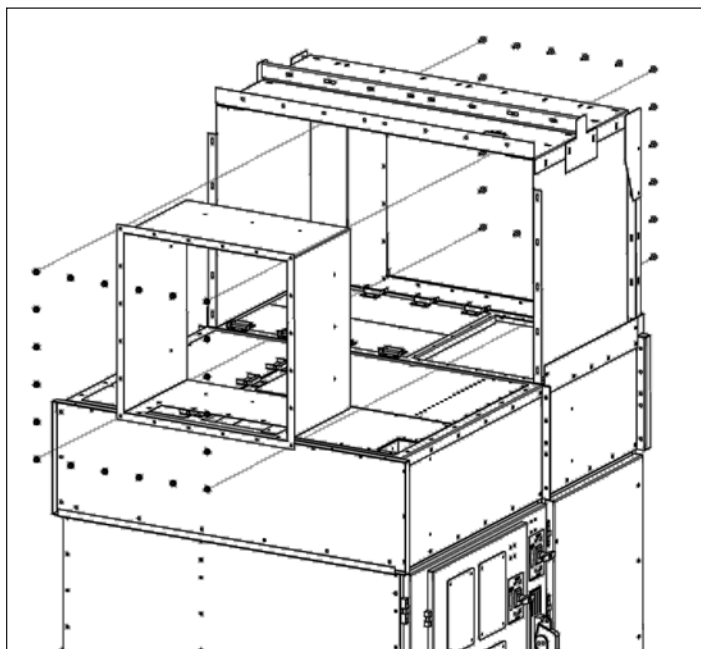

Figure 44. Installing Duct Collar into Plenum

4.3. Parts Identification

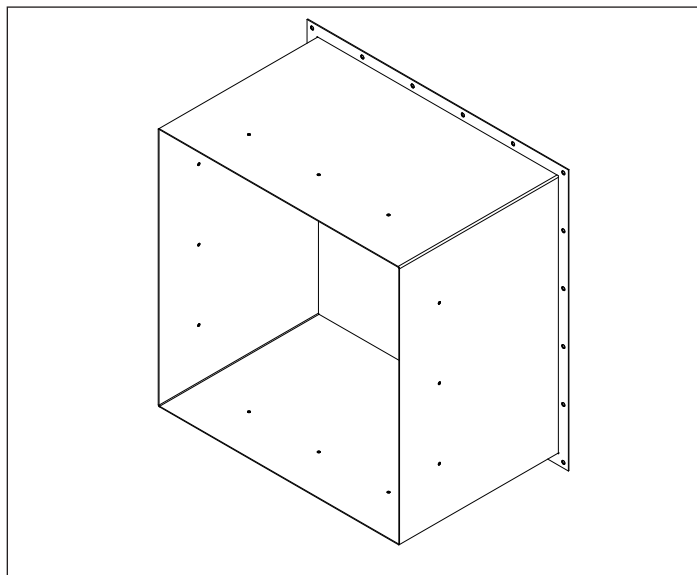

Figure 45. Duct Collar

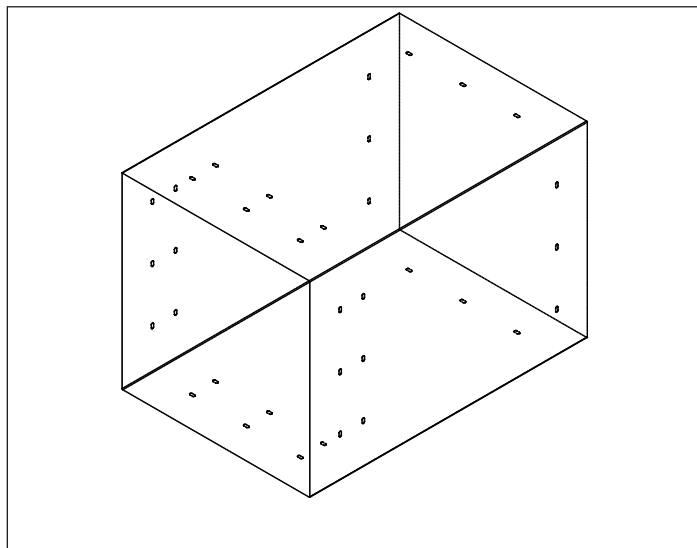

Figure 46. Duct Section

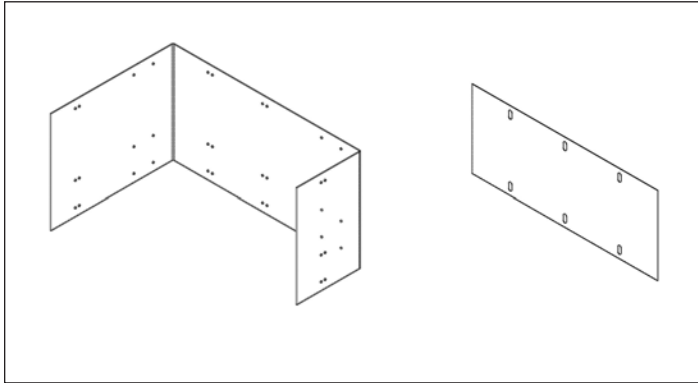

Figure 47. Seam Connector and Seam Cover

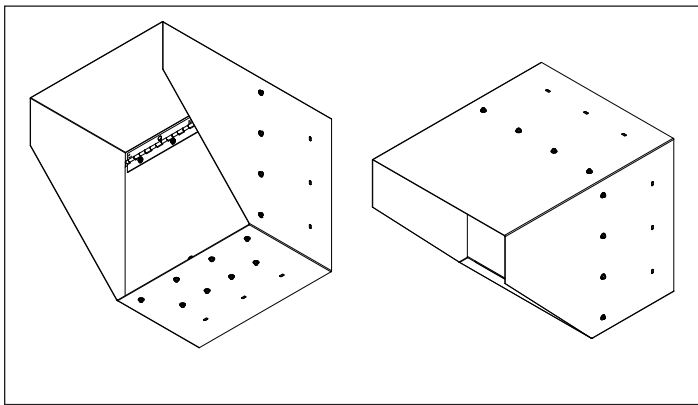

Figure 48. Duct End Assembly

4.4 Duct Installation

Step 1

⚠ WARNING

DO NOT OVER-TIGHTEN SELF-TAPPING SCREWS. IF ANY SELF TAPPING SCREWS STRIP DURING INSTALLATION, THEY MUST HAVE A NUT INSTALLED ON THE INSIDE TO SECURE THEM. THE NUT SHOULD BE INSTALLED TO THE SAME TORQUE VALUE AS THE SELF-TAPPING SCREW. FOR THIS REASON, AIR-POWERED IMPACT TOOLS ARE NOT RECOMMENDED.

Ensure duct collars are installed in plenum openings. If any collars are missing, follow the instructions in 4.2 to install them. In order to attach duct sections, proceed to step 2. Some installations do not require additional duct length, so a duct end assembly is installed directly onto the duct collar – for these cases, skip to step 7.

Step 2

Assemble a duct section onto the duct collar; the collar slides inside the duct section. Ensure that the duct section is oriented correctly: all duct sections should be turned so the end with 2 rows of holes is toward the duct exit. Fasten the duct section in place with 12x ¼" self tapping screws (see **Figure 49**).

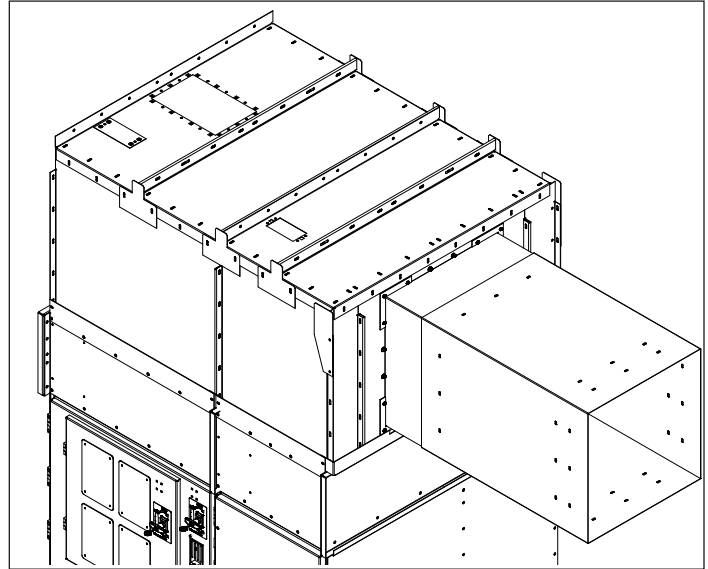

Figure 49. First Duct Section Installed

Step 3

Install 2 duct seam connectors into the end of the last duct section using 12 ¼" self tapping screws in the holes closest to the plenum. The connectors must be oriented so their hole pattern matches the duct section.

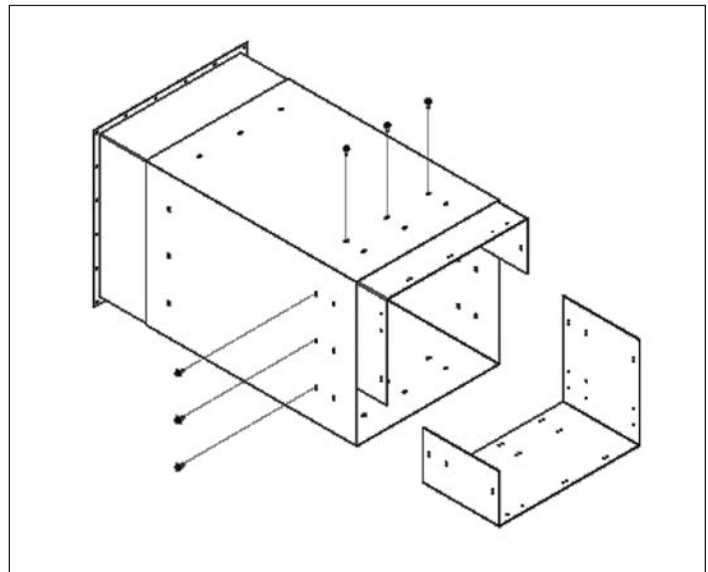

Figure 50. Installing Seam Connectors

Step 4:

Slide the next duct piece over the splice pieces, ensuring the holes match.

Step 5:

Install a splice cover plate on each surface of the duct joint (4 covers total) using 1/4" self tapping screws (6 screws each) (see **Figure 51**).

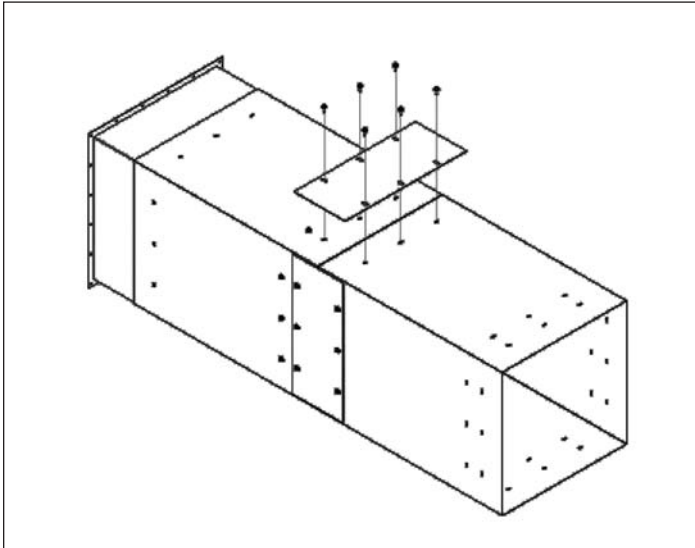

Figure 51. Installing Seam Covers

Step 6:

Repeat steps 3-5 until the duct exit is reached, using either additional duct sections or optional elbows.

Step 7:

At the exit of the duct, install a duct end assembly onto the last section of duct, following steps 3-5.

Step 8:

Secure the exhaust flap on the duct end assembly with a push-in fastener or magnetic latch (if applicable).

Step 9:

Attach the duct end assembly to the duct as with the regular duct sections above.

4.4. Duct support

Duct must be supported every 120" (3m). in both the horizontal and vertical directions. Standard hanging straps may be used, however support hardware may NOT be drilled or screwed into the duct. Modification of the plenum or duct without approval from Eaton engineering will compromise the arc resistant rating of the entire lineup.

69C4455G01 - Arc duct hanger assembly is available from Eaton. Contact your factory representative to order.

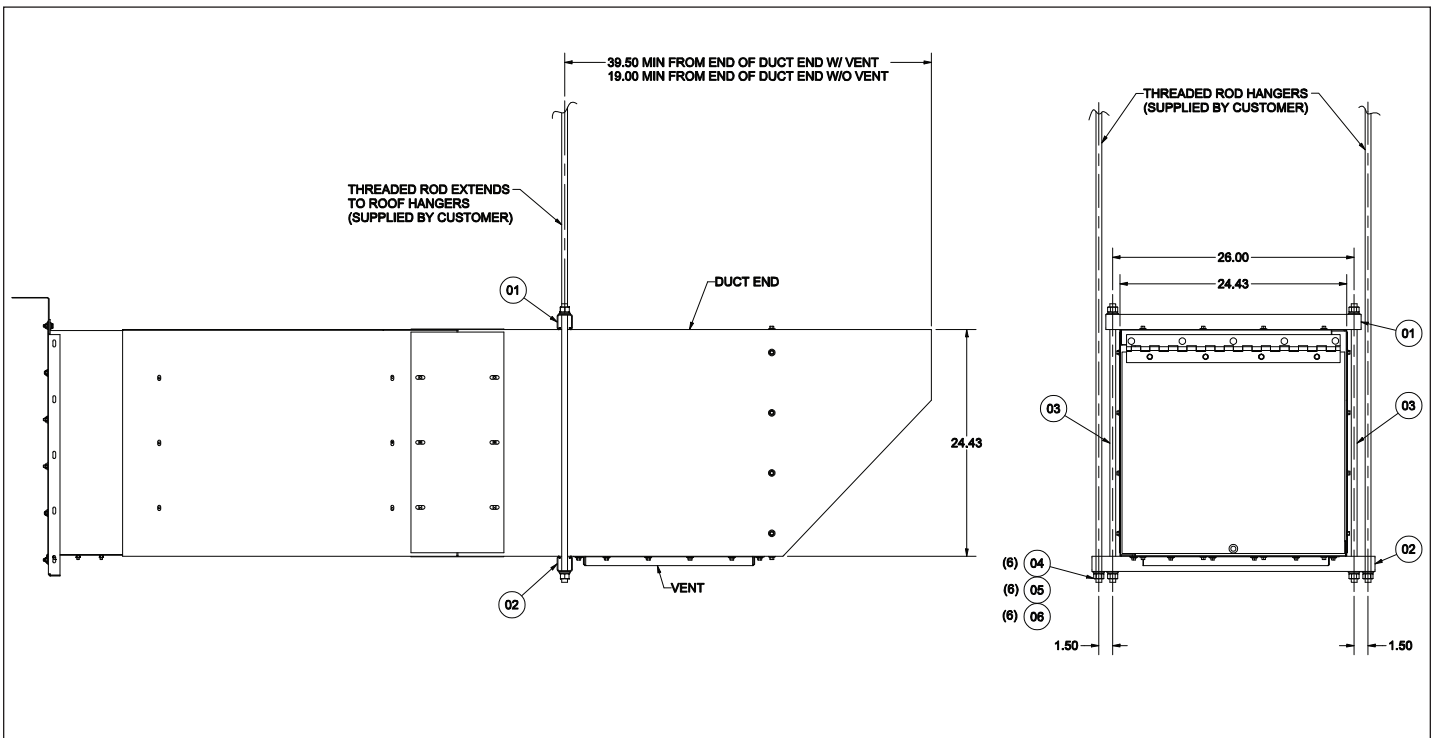

Figure 52. Arc Duct Hanger Assembly

Section 5: Inspection and Maintenance

Ensure that plenum and duct have no loose or missing hardware. If any self tapping screws are stripped out install a ¼-20 nut with locking hardware on the backside of the screw and torque per Table 2.

Periodically inspect the air filter on the duct, if present and replace if soiled or clogged.

Section 6: Renewal Parts

When ordering renewal or spare parts, include as much information as possible. In many cases, the style number of the new part can be obtained from identification on the old part. Always include a description of the part. Specify the rating, structure number, and shop order number, located on the nameplate of each section,

Notes:

The instructions for installation, testing, maintenance, or repair herein are provided for the use of the product in general commercial applications and may not be appropriate for use in nuclear applications. Additional instructions may be available upon specific request to replace, amend, or supplement these instructions to qualify them for use with the product in safety-related applications in a nuclear facility.

The information, recommendations, descriptions, and safety notations in this document are based on Eaton's experience and judgment with respect to Retrofitting of Power Breakers. This instructional literature is published solely for information purposes and should not be considered all-inclusive. If further information is required, you should consult an authorized Eaton sales representative.

The sale of the product shown in this literature is subject to the terms and conditions outlined in appropriate Eaton selling policies or other contractual agreement between the parties. This literature is not intended to and does not enlarge or add to any such contract. The sole source governing the rights and remedies of any purchaser of this equipment is the contract between the purchaser and Eaton.

NO WARRANTIES, EXPRESSED OR IMPLIED, INCLUDING WARRANTIES OF FITNESS FOR A PARTICULAR PURPOSE OR MERCHANTABILITY, OR WARRANTIES ARISING FROM COURSE OF DEALING OR USAGE OF TRADE, ARE MADE REGARDING THE INFORMATION, RECOMMENDATIONS, AND DESCRIPTIONS CONTAINED HEREIN.

In no event will Eaton be responsible to the purchaser or user in contract, in tort (including negligence), strict liability or otherwise for any special, indirect, incidental or consequential damage or loss whatsoever, including but not limited to damage or loss of use of equipment, plant or power system, cost of capital, loss of power, additional expenses in the use of existing power facilities, or claims against the purchaser or user by its customers resulting from the use of the information, recommendations and description contained herein.

Eaton Corporation
Electrical Group
1000 Cherrington Parkway
Moon Township, PA 15108
United States
877-ETN-CARE (877-386-2273)
Eaton.com

© 2011 Eaton Corporation
All Rights Reserved
Printed in USA
Publication No. IB48077E / TBG000499
July 2011