

# SPEAR® single-phase recloser system



## Contents

Description	Page	Description	Page
Description . . . . .	2	Control Features . . . . .	13
Ordering Information . . . . .	2	Control Security . . . . .	13
Constructing a Recloser Catalog Number . . . . .	3	Protection Profiles . . . . .	13
Recloser Options and Mounting Equipment . . . . .	3	Reclosing and Overcurrent Protection/TCCs . . . . .	13
Constructing a Control Catalog Number . . . . .	5	High Current Lockout . . . . .	13
Control Accessories . . . . .	6	Cold Load Pickup . . . . .	13
Recloser Features . . . . .	8	Hot Line Tag . . . . .	13
Ratings and Characteristic Features . . . . .	8	Fast Trips Disabled . . . . .	13
Operation . . . . .	8	Sequence Coordination . . . . .	13
Vacuum Interruption . . . . .	8	Manual Close Time Delay . . . . .	13
Surge Protection . . . . .	8	Metering . . . . .	13
Recloser Operation . . . . .	8	Diagnostic Tools . . . . .	13
Construction . . . . .	8	Recloser Wear Monitor . . . . .	14
Vacuum Interrupters . . . . .	9	Sequence of Events Recorder . . . . .	14
Manual Operation . . . . .	9	Data Profiler . . . . .	14
Accessories . . . . .	9	Contact Input/Output (I/O) Module Option . . . . .	14
Ratings and Specifications . . . . .	10	Communications . . . . .	14
		Font Panel Human Machine Interface (HMI) . . . . .	15
		Display LCD Module . . . . .	15
		User Interface and LED Indicators . . . . .	15
		Operating Panel . . . . .	16
		One-Touch Function Keys . . . . .	17
		Operation Upon Loss of AC Power . . . . .	17
		Accessories . . . . .	17



Powering Business Worldwide

## Description

Eaton's Cooper Power™ series SPEAR® single-phase recloser and control is the latest addition to its product offering for single-phase electronically controlled reclosers. This solution provides reliable, economical overcurrent protection, advanced metering, and SCADA communications for distribution circuits rated through 34.5 kV.

Specifically with the SPEAR recloser, it uses a solid cycloaliphatic-epoxy polymer with an encapsulated vacuum interrupter. The SPEAR recloser's mechanism is reliable, lightweight, and utilizes a magnetic actuator to provide a lifetime of trouble free operation. The solid polymer system does not rely on a gaseous, liquid, or foam dielectric insulating material. The SPEAR recloser is highly resistant to ozone, oxygen, moisture, contamination, and ultraviolet light.

Designed and tested with the SPEAR control, the SPEAR recloser offers superior coordination, protection, and application capabilities. Recloser operations are programmed using the SPEAR control with accurate characteristics and a host of advanced features. Precise operating tolerances enable close coordination with other protective devices on the system. When system requirements change, program settings are easily altered with no sacrifice of accuracy or consistency.

Compact and lightweight, SPEAR reclosers are easily installed on poles or in substations. Mounting equipment is available for both pole and substation mounting applications.

Recloser and control accessories enable further tailoring of the protective program to achieve maximum system operating flexibility.

The SPEAR control is the next in a line of fully integrated controls developed by Eaton. This means one standard operating system and front panel to train technicians on. This translates to fewer training expenses, reduced inventory, and a distribution system that is much easier to maintain.

In addition to the flexible and user-friendly platform, the new SPEAR control has the communications technology to take your system into the future. With fully modular communication compatibilities, the SPEAR control supports cellular and radio communications utilizing Serial DNP3 protocol. A side panel RS-232 communications port is available for connection to SCADA or other devices. The communication port is accessed by swing the control panel forward.

The SPEAR control can compute power, energy, power factor, and power flow direction based upon the recloser's CT current output, and the customer supplied voltage input.

The standardized front panel of the SPEAR control can be used to program and interrogate the control, as well as to display metering and alarm information. Control parameters can also be programmed via personal computer using Eaton's Cooper Power series ProView® NXG interface software. Temporary connection to the control can be made through the front panel USB port allowing programming and data downloads to a laptop or PC. The ProView NXG interface software includes the functionality modify time-current curves (TCCs), and provide diagnostic information. The SPEAR control analysis tools include event recording, data profiling, and various metering capabilities.

## Ordering information

To order a basic SPEAR recloser:

- See the **Constructing a recloser catalog number** section to construct a catalog number that describes the required recloser.
- From Tables 1 through 5, specify the catalog numbers that describe the required accessories.

To order a basic SPEAR control:

- On page 5, see the **Constructing a control catalog number** section that describes the required control.
- From Table 6, specify the catalog number that describes the required control cable.
- From Tables 7 through 12, specify the catalog numbers that describe the required accessories.

### Constructing a recloser catalog number

To order a basic SPEAR recloser, 15 kV, with 8 kA fault interrupting and 400 amp continuous current, the catalog number would be constructed in this manner:

**KSPEAR** Basic letters for a SPEAR recloser

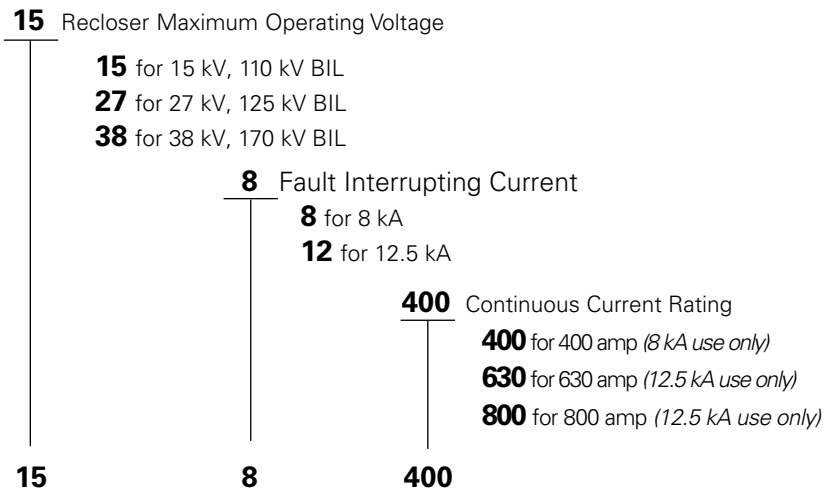

*KSPEAR15-8-400 is the catalog number for the required basic SPEAR recloser.*

### Recloser options and mounting equipment

**Table 1. Rating Impulse Voltage (BIL) Options**

Description	Catalog Number
125 kV BIL for KSPEAR15	KSPR-255-60
150 kV BIL for KSPEAR27	KSPR-255-61

**Table 2. Tank and Heater Options**

Description	Catalog Number
<b>120 Vac Heater</b>	
Mild steel tank	KSPR-MS-120
Stainless steel tank	KSPR-SS-120
<b>240 Vac heater</b>	
Mild steel tank	KSPR-MS-240
Stainless steel tank	KSPR-SS-240

**Table 3. Bushing Terminals**

Description	Catalog Number
Standard eyebolt terminals, 1/0-500 MCM †	KSPR-201-21
Eyebolt terminals, 4/0-1000 MCM ‡	KSPR-201-22
2-hole flat pad terminals †	KSPR-201-23
4-hole flat pad terminals	KSPR-204-24
Stud-style terminals, 1.125 dia. threaded	KSPR-201-25

† For use with 400 and 630 amp continuous current only

‡ For use with 800 amp continuous current only

Effective June 2016

**Table 4. Miscellaneous Accessory Options**

<b>Description</b>	<b>Catalog Number</b>
Wildlife restraints, set of 2	KSPR-56-7
<b>Terminal shields for enhanced environmental protection, set of 2</b>	
for 400 or 630 amp eyebolt, 2-hole flat pad or stud terminals	KSPR-245-1
for 800 amp eyebolt or 4-hole flat pad terminals	KSPR-245-2

**Table 5. Mounting Equipment Options**

<b>Description</b>	<b>Catalog Number</b>
Pole mounting extension †	KSPR-364
Crossarm mounting bracket, set of 2	KA39H2
<b>Arrester mounting brackets</b>	
<b>Standard, galvanized steel</b>	
Set of 1	KSPR-932-2
Set of 2	KSPR-932-1
<b>Stainless steel</b>	
Set of 1	KSPR-932-4
Set of 2	KSPR-932-3

† Pole mounting extension bracket is required for any recloser application greater than 125 kV BIL.

### Constructing a control catalog number

To order a basic SPEAR control for use with the SPEAR recloser, for 120 Vac primary power, with a standard 8 amp-hour battery, mild steel cabinet, standard 2 input/output auxiliary contacts, standard DNP protocol, no communication interface and English language, the catalog number would be constructed in this manner:

**KSPEARC** Basic letters for a SPEAR control

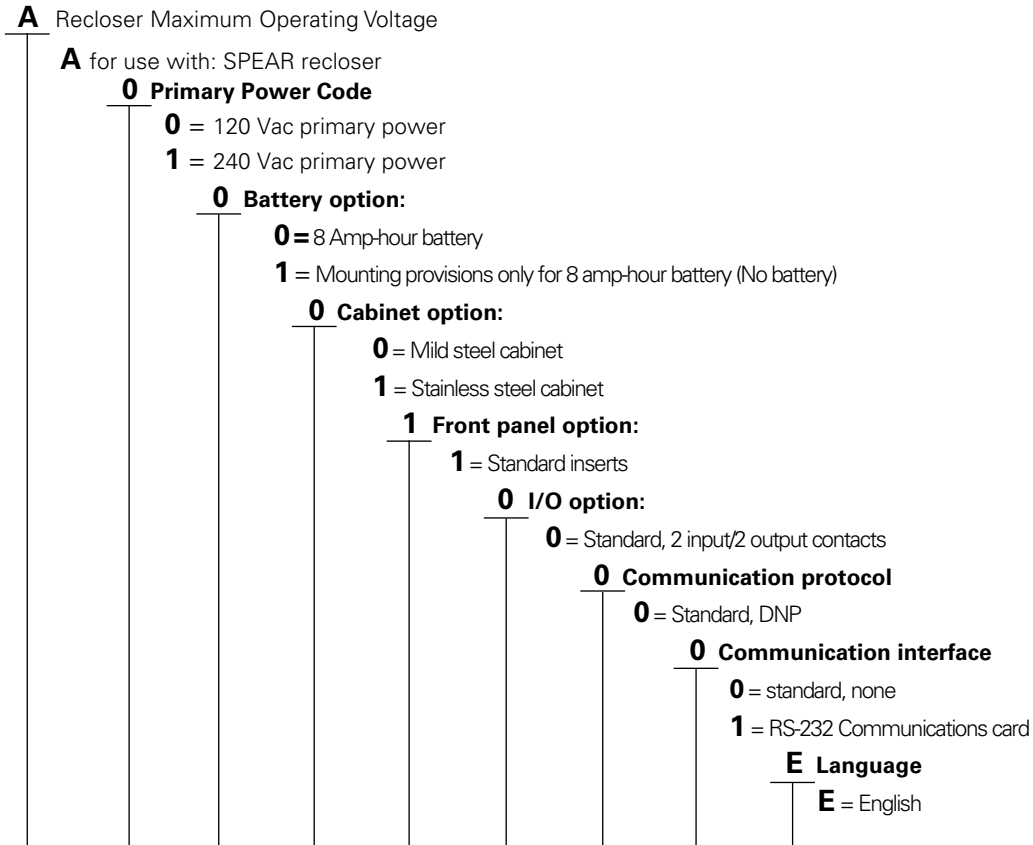

**KSPEARC A 0 0 0 1 0 0 0 0 E**

*KSPEARCA0001000E is the catalog number for the control in the example above.*

## Control accessories

**Table 6. Control Cables**

Description	Catalog Number
Control cable: (basic cable, no length)	KA148ME
Replace "X" with desired length. Select from 5 to 50 feet.	KA148ME-X
Armored (10 ft.) control cable: (basic cable, no length)	KA149ME
Replace "X" with desired length. Select from 11 to 50 feet.	KA149ME-X

**Table 7. Receptacles and Wiring**

Description	Catalog Number
AC input receptacles	
120 Vac or 240 Vac input receptacle, 2-pin	KSPRC-1775-H
120 Vac input receptacle, 3-pin	KSPRC-1775-J
No input receptacle; for hard-wiring input	KSPRC-1775-0

**Table 8. Input Cables**

Description	Catalog Number
AC input cables	
Input cable, 120 or 240 Vac, two-wire for 2-pin input, for use with <b>KSPRC-1775-H</b> receptacle. (Basic cable, no length)	KA11ME1
Replace "X" with desired length. Select from 0-50 feet.*	KA11ME1-X
Armored (10 ft) input cable: (Basic cable, no length)	KA124ME
Replace "X" with desired length. Select from 10-50 feet.	KA124ME-X
Input cable, 120 Vac, three-wire for 3-pin input, for use with <b>KSPRC-1775-J</b> receptacle. (Basic cable, no length)	KME4-67-3
Replace "X" with desired length. Select from 0-50 feet.*	KME4-67-3-X

\* To order a mating plug body only (no cable, for customer supplied cable), enter length as "0".

**Table 9. Automation Packages†**

<b>Description</b>	<b>Catalog Number</b>
Wireless communication provisions package	
Includes 13.5 Vdc interface board and radio mounting tray (Radio and communications interface card not included)	KSPRC-1774-29
Cellular communications connection and protection package:	
32" SMA(m)-N(m) coax pigtail, 700 MHz-2 GHz Polyphaser and mounting hardware, N(f)-type external termination	KSPRC-1774-22*
WiFi/Max communications connection and protection package	
32" SMA(m)-N(m) coax pigtail, 2 GHz-6 GHz Polyphaser and mounting hardware, N(f)-type external termination, TNC(m)-SMA(f) inline coaxial adapter	KSPRC-1774-23*
125 MHz-1 GHz N-terminated radio connection and protection package	
25" N(m)-N(m) coax pigtail, 125 MHz-1 GHz Polyphaser and mounting hardware, N(f)-type external termination	KSPRC-1774-24*
700 MHz-2 GHz TNC-terminated radio connection and protection package	
32" TNC(m)-N(m) coax pigtail, 700 MHz-2 GHz Polyphaser and mounting hardware N(f)-type external termination	KSPRC-1774-25*
Polyphaser and mounting hardware - 125 MHz-1 GHz	KSPRC-1775-A*
Polyphaser and mounting hardware - 700 MHz-2 GHz	KSPRC-1775-B*
Polyphaser and mounting hardware - 2 GHz-6 GHz	KSPRC-1775-C*

† Required Communication Interface Option: (1) RS-232 Interface

\* Requires that the KSPRC-1774-29 Wireless Communication Provisions Package also be ordered

**Table 10. Communication Support Equipment**

<b>Description</b>	<b>Catalog Number</b>
USB Cable: Type A male to Type B male connectors 2.0 meters (6.5 feet) length	KSPRC-66

**Table 11. Cable Locking Sleeves**

<b>Description</b>	<b>Catalog Number</b>
Cable locking sleeve, quantity 1	KSPRC-1772-1
Cable locking sleeve, quantity 2	KSPRC-1772-2
Cable locking sleeve, quantity 3	KSPRC-1772-3

**Table 12. Miscellaneous Accessories**

<b>Description</b>	<b>Catalog Number</b>
120 Vac Battery charger for spare batteries	KME5-60-1
Adapter cable, 15 ft., for use with KMET Tester	KSPRC-145-15

## Recloser features

### Ratings and characteristic features

Single-phase protection on systems rated 2.4 through 14.4 kV is provided by SPEAR15 reclosers. SPEAR27 reclosers can be applied on systems rated through 27.0 kV. Higher-voltage system protection at 34.5 kV is provided by Type SPEAR38 reclosers. A ratings summary for SPEAR reclosers is shown in Table 13.

### Operation

Sensing current transformers, embedded in the recloser, supply fault-sensing information to the electronic control. Tripping and closing signals from the control energize the operating circuits in the recloser. Due to a single CT ratio for all ratings, minimum-trip values of the electronic control are independent of the continuous-current and interrupting ratings of the recloser.

Flexibility in coordination with other protective devices is provided by varied time–current characteristics from a choice of standard or customized curves, minimum trip values, reclosing and resetting time settings, and a selection of accessories.

### Vacuum interruption

A single break on each phase is accomplished by separating contacts inside the vacuum interrupter. All arcing is contained within the vacuum envelope. The patented axial-magnetic vacuum interrupters, used in SPEAR reclosers, offers extended and increased duty cycles compared with oil or radial-magnetic interrupters. The axial-magnetic field keeps the arc in a diffused mode, resulting in less arc power to be dissipated, resulting in low thermal stress, suitable for encapsulation.

### Surge protection

Best operating results are achieved if reclosers are protected with surge arresters. On line applications, arrester protection is recommended on both sides of the recloser. (If protection is on one side only, it should be on the source side. In substations, arresters should be on the load side.) Eaton's Cooper Power series distribution-class arresters provide excellent protection and are available with mounting brackets to fit SPEAR reclosers.



Figure 1. SPEAR recloser

### Recloser operation

Fault currents are sensed by one 1000:1 ratio sensing current transformer embedded in the recloser. This CT provides a continuous measurement of line current, monitored by the electronic control. When current level exceeds the programmed minimum trip level, the magnitude of the overcurrent is integrated with time, using a programmed time–current curve characteristic. The control then signals the trip in the recloser, opening the main contact of the encapsulated vacuum bottle.

The control signals tripping and closing. The recloser always maintains energy for a tripping operation following a closing operation. The electronic recloser control provides determination of phase trip sequences and operations to lockout and reclosing and resetting timing, adjustable with the control without de-energizing the recloser.

### Construction

#### Recloser

Designed for long service life and no maintenance, the SPEAR recloser has a solid-polymer interrupter module with an embedded current transformer and a standard mild steel mechanism housing; light gray is the standard color.

Cycloaliphatic-epoxy polymer encapsulation provides solid insulation and maintenance-free, environmentally safe operation. There is no monitoring or maintaining of gas pressure or oil levels; there are no toxic or environmentally unfriendly materials.

There are no foam fillers or insulation seals, eliminating potential moisture ingress areas. The SPEAR recloser module exhibits good absorption of elastic energy and resistance to cracking and crack propagation. Additionally, durable environmental properties make the solid polymer suitable for outdoor applications, including seacoasts, deserts, and areas of high pollution.

#### Surface tracking

The cycloaliphatic epoxy is highly resistant to contaminants and resists tracking and flashovers under extreme pollution levels to reduce both flashovers and the associated cost of repairs.

#### Hydrophobicity

The module maintains excellent hydrophobicity, a property characterized by water beading into isolated drops, and is highly resistant to moisture absorption. Hydrophobicity prevents continuous sheets of water from forming leakage current paths that deteriorate the creepage withstand level.

#### Ultraviolet resistance

The cycloaliphatic epoxy resists ultraviolet radiation damage even in harsh climates, maintaining a smooth, unblemished, self-cleansing surface with low-adhesion to contaminants.

#### Tensile strength

Outstanding tensile and flexural strength characteristics mean the SPEAR recloser module is tough and non-fragmenting, reducing shipment and handling charges.

#### Shed design

The shed design utilizes alternate sized skirts. The major sheds shield and protect the minor sheds to enhance the hydrophobicity and ultraviolet resistance of the module, eliminate formation of microcracks, and ensure extra-protected creepage. Additionally, sharp edges direct water away from the unit. Water paths and ice formations are effectively eliminated.

#### Flashover recovery

Flashovers occur when an object, usually wildlife, contacts energized parts of the equipment. The SPEAR recloser minimizes the effect of flashovers with remarkable physical resilience, arc-quenching properties, and a self-healing ability. SPEAR reclosers can withstand



the enormous forces experienced during faults without wholesale damage and allows reenergizing after external flashover without cleaning.

### Vacuum interrupters

SPEAR reclosers use vacuum as the interrupting medium. Vacuum interrupters (Figure 2) provide fast, low-energy arc interruption with long contact and interrupter life, low mechanical stress, and maximum operating safety. With arc interruption taking place in a vacuum, contact and interrupter life are several times greater than interruption in oil, virtually eliminating interrupter maintenance.



**Figure 2. Cross section of a vacuum interrupter used in SPEAR reclosers.**

Eaton's Cooper Power series vacuum interrupters are designed with a metal and ceramic housing for maximum strength and long-term vacuum integrity. Oxygen-free, high conductivity copper, stainless steel, and a nickel-copper alloy are used in the vacuum interrupters. The high alumina ceramic has more than five times the strength of glass, which permits a higher processing temperature to develop maximum purity of the assembly, and is impervious to helium penetration, maintaining the vacuum level. Additionally, it provides wear resistance, chemical resistance, and a high dielectric strength.

Enclosed in the interrupter is a stationary and a moving contact assembly. The moving contact has a travel of approximately one-half inch, its shaft passing through a flexible bellows that maintains vacuum integrity. Contacts consist of a high purity copper sintered with aluminothermic chromium.

Because the smallest amount of internal contamination can significantly shorten the life of a vacuum interrupter, special care is taken to avoid even minute contamination from any source, including dust particles, machining oils, or human body salts. No paraffinic oils are used in the machining process, all machined parts are put through a cleaning/ degreasing process, and then all components are electro-polished in a positive-pressure, air-filtered area. A Class 100 clean room facility is used for the final interrupter production. The furnaces employ a custom-designed, three-stage pumping system to yield high levels of vacuum. Every vacuum interrupter is then tested and tracked with individual serial numbers.

### Manual operation

The recloser can be opened manually with a hotstick to pull down the yellow manual OPEN handle under the sleet hood. With the handle in the OPEN position, the control cannot close the recloser.

The recloser is closed, following a manual open, by pushing the yellow handle back under the sleet hood and then using the electronic control to close the recloser.

Similarly, the recloser can be operated from the manual control switch on the electronic control panel, provided the manual operating handle is up. A red contact position indicator flag, adjacent to the manual operating handle, shows recloser contact position.

### Accessories

#### Terminals

The standard terminal is an eyebolt, 1/0–500 MCM (630 A). Eyebolt 4/0– 1000 MCM (800 A), 2-hole and 4-hole, flat-pad terminals, and stud-type terminals are available as an accessory.

#### Pole-mounting hanger

A pole-mounting hanger, which bolts directly to the recloser tank, is available for pole-mounting installation.

#### Arrester-mounting brackets

The arrester-mounting bracket accessory can be bolted to the recloser tank. The arresters are not included with the brackets.

**Table 13. Ratings and specifications**

<b>Rating</b>	<b>15-8-400</b>	<b>15-12-630</b>	<b>15-12-800</b>	<b>27-8-400</b>	<b>27-12-630</b>	<b>27-12-800</b>	<b>38-8-400</b>	<b>38-12-630</b>	<b>38-12-800</b>
Maximum Design Voltage (kV)	15.5	15.5	15.5	27.0	27.0	27.0	38.0	38.0	38.0
Nominal Operating Voltage (kV)	14.4	14.4	14.4	24.9	24.9	24.9	34.5	34.5	34.5
Basic Insulation Level (BIL*) (kV)	110	110	110	125	125	125	170	170	170
<b>60 Hertz Withstand Voltage (kV)</b>									
Dry, one minute	50	50	50	60	60	60	70	70	70
Wet, ten seconds	45	45	45	50	50	50	60	60	60
<b>Max RIV at 1.0 MHz</b>									
9.4 kV (µV)	100	100	100						
16.4 kV (µV)				100	100	100			
23.0 kV (µV)							100	100	100
Continuous Current Ratings (A)	400	630	800	400	630	800	400	630	800
Sym. Interrupting Current (A)	8,000	12,500	12,500	8,000	12,500	12,500	8,000	12,500	12,500
<b>Overload Capability</b>									
125% - 8 Hours (A)	500	788	None	500	788	None	500	788	None
150% - 4 Hours (A)	600	945	–	600	945	–	600	945	–
Cable Charging Current (A)	10	10	10	25	25	25	40	40	40
Line Charging Current (A)	2	2	2	5	5	5	5	5	5
Three-Second Current, Sym. (A)	8,000	12,500	12,500	8,000	12,500	12,500	8,000	12,500	12,500

\*Extended BIL option available on 15.5 kV and 27 kV products.

**Table 14. Mechanical Life**

<b>Minimum Operations</b>	10,000
---------------------------	--------

**Table 15. Duty Cycle**

<b>Percent of Maximum Circuit Interrupting Rating</b>	<b>Minimum X/R Ratio</b>	<b>Number of Unit Operations at 12.5 kA</b>
15-20	4	88
45-55	8	112
90-100	17	32
		Total 232

**Table 16. Mass (Weight) per Single-Phase Recloser**

<b>Recloser</b>	<b>SPEAR15</b>	<b>SPEAR27</b>	<b>SPEAR38</b>
lbs (kg)	114 (52)	118 (54)	122 (56)

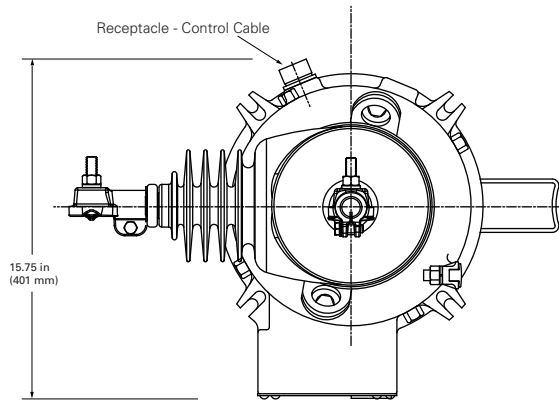

**Creepage Distances**

Description	SPEAR15	SPEAR27	SPEAR38
Terminal to Terminal	40.9 in 1039 mm	40.9 in 1039 mm	40.9 in 1039 mm
Lower Terminal to Ground	26.5 in 673 mm	30.5 in 775 mm	37.5 in 953 mm

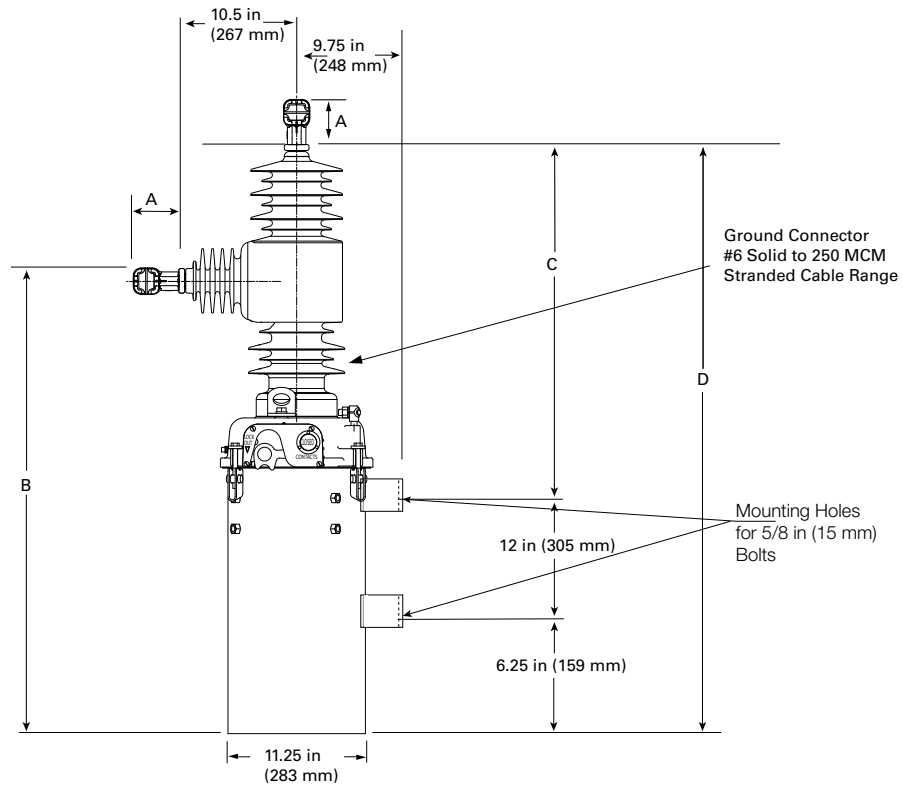

**SPEAR Recloser Dimensions**

	B	C	D
SPEAR15	34.5 in 876 mm	27.5 in 699 mm	45.5 in 1156 mm
SPEAR27	36.75 in 933 mm	29.5 in 749 mm	47.75 in 1213 mm
SPEAR38	40.5 in 1029 mm	33.5 in 851 mm	51.5 in 1308 mm

**Terminal Option Type**

**Dimension A**

Eyebolt - (630 A) 1/0 to 500 MCM Cable Range	3.25 in/83 mm
Eyebolt - (800 A) 4/0 to 1000 MCM Cable Range	4.25 in/108 mm
Flat Pad - 2 Hole (630 A max)	4.5 in/114 mm
Flat Pad - 4 Hole (800 A max)	4.75 in/121 mm
Stud Type - (800 A max) 1.125 - 12 threads	3.25 in/83 mm

Figure 3. Recloser dimensions.

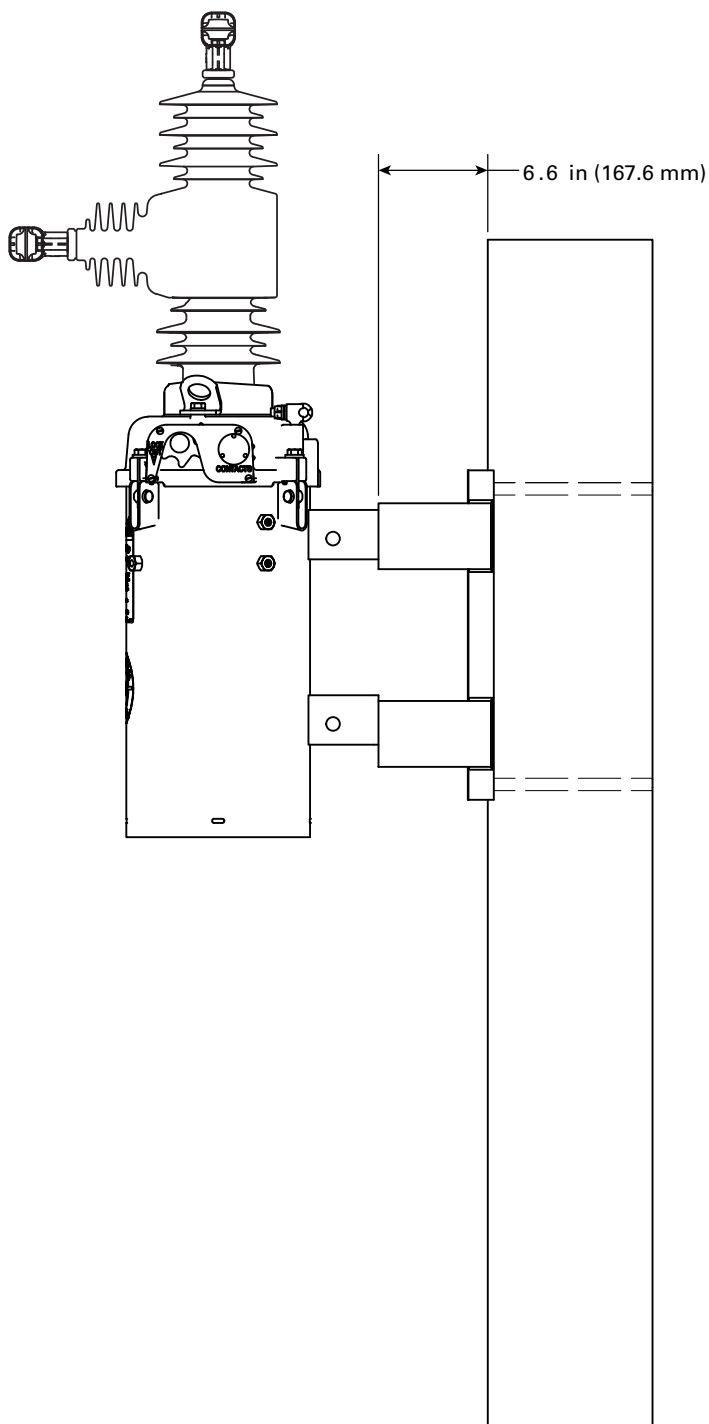

**SPEAR Recloser Side View**

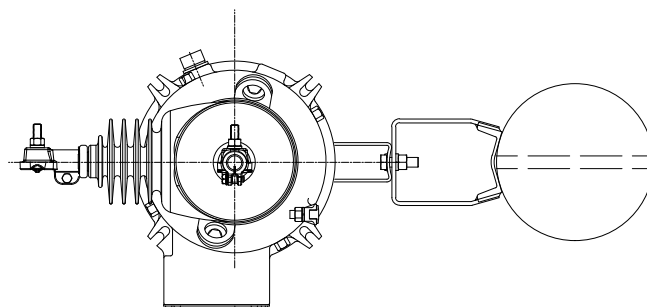

**SPEAR Recloser Top View**

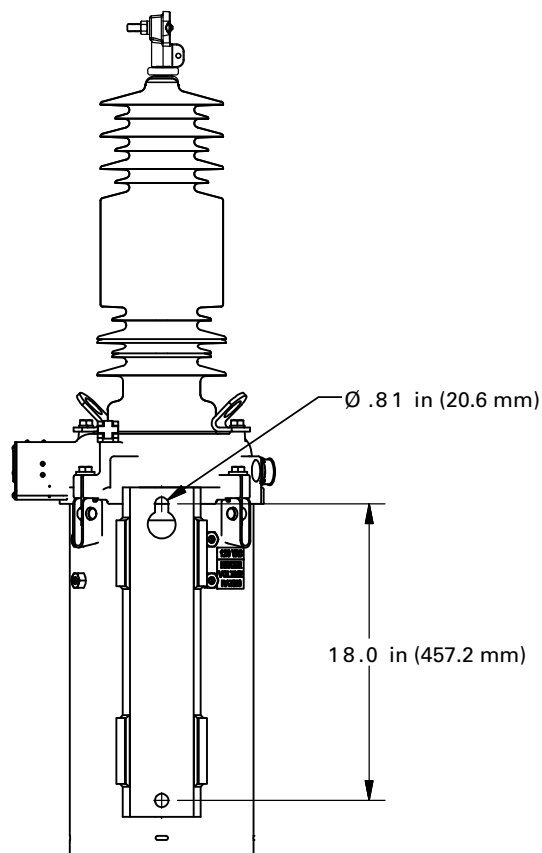

**SPEAR Recloser Mounting Channel Dimensions.**

**Note:** Dimensions for recloser are shown on page 11.

**Figure 4. Recloser dimensions with pole-mounting accessory.**

## Control features

### Control security

The SPEAR single-phase recloser control has multiple customer-programmable security codes to limit control programming and viewing function access to authorized personnel. The SPEAR control is capable of supporting numeric passwords. The front panel Human-Machine Interface (HMI) includes a user-selected security code to access the settings. Plus, the ProView NXG interface software has its own security levels for multiple-user access.

### Protection profiles

The SPEAR control provides two protection profiles, each capable of fully specifying the operation of the control. The protection profiles are selectable through the front-panel push button interface or through the interface software and USB communication port. Each protection profile contains overcurrent protection and operation settings.

### Reclosing and overcurrent protection/TCCs

The SPEAR control offers flexible phase overcurrent protection which can be programmed with up to four operations-to-lockout. Each time-current curve (TCC) can be individually programmed from up to fifty-four standard curves which can be further customized. Time-current curves are available for fast and delayed operations. Reclose intervals and reset time can also be programmed by the user.

### High current lockout

The High Current Lockout (HCL) feature will automatically lockout the control when the current exceeds a programmed threshold. The active number of selectable operations to lockout is independently selectable for each protection profile.

### Cold load pickup

The SPEAR control provides a Cold Load Pickup (CLPU) feature that will prevent the control from tripping due to short-term increases in current caused by loss of normal load diversity or feeder inrush. This feature has an independently programmable minimum trip value, time-current curve, reclose interval, and number of operations to lockout for each protection profile. The CLPU feature will also inhibit 'normal' overcurrent protection during the CLPU active time.

### Hot line tag

The SPEAR control includes a Hot Line Tag (HLT) membrane push button that will block all Close operations, local or remote, for live-line work. The control will trip on one operation-to-lockout on the composite curve of the HLT definite time and the TCC1 curve, whichever is faster, when HLT is active. Hot Line Tag takes precedence over Cold Load Pickup, Non-Reclosing, and Fast Trips Disabled. The Hot Line Tag time delay is independently selectable for each protection profile.

### Fast trips disabled

The Fast Trips Disabled feature will ignore the normal TCCs and number of trips and instead use the Fast Trips Disabled settings when Fast Trips Disabled is active. Fast Trips Disabled is independently selectable for each protection profile.

## Sequence coordination

The SPEAR control Sequence Coordination feature will allow the control to step through selected operations in the operating sequence without tripping when a down-line recloser is proceeding through its reclose sequence. The number of advances is programmable from one to three operations to provide trip coordination with the down-line recloser.

### Manual close time delay

The SPEAR control includes a Manual Close Delay which provides a delay from the time the manual CLOSE button is pushed to the time the manual close operation is performed.

### Metering

The SPEAR control comes equipped with a full complement of metering capabilities, which include instantaneous, demand, demand peak, and energy metering. The control will be capable of the following metering values:

- Real and reactive power, including direction of power flow
- Demand currents
- Instantaneous currents
- Instantaneous voltage
- Instantaneous frequency
- Energy
- Instantaneous power factor
- Metering Settings which include demand interval, and alarm thresholds for current, voltage, frequency, power factor, frequency, kVA, kVAR, and kW

### Diagnostic tools

The SPEAR control comes complete with a suite of diagnostic tools to help troubleshoot problems, analyze system events and conditions, and monitor the life of your recloser. All diagnostic information is stored in non-volatile memory so even if the control loses power, all system and event information will remain intact.

### Recloser wear monitor

The Recloser Wear Monitor will observe the life of the recloser apparatus by recording how many times the recloser has been opened as well as keep track of the current interrupted in percentage compared to preset total Duty Cycle Factor. The monitor allows for programmable entries to preset the duty of an existing recloser.

### Sequence of events recorder

The Sequence of Events (SOE) Recorder is capable of capturing discrete events such as Open/Close status changes, faults, mechanism failures, etc. The SOE places an accurate time stamp and analog information on the events and stores them in non-volatile memory so they won't be lost in the event that the control loses power. The SOE recorder is capable of maintaining up to 1000 events and can record up to 48 different event types, including overcurrent trip, control trip, non-reclose ON/OFF, external alarm, and control lockout.

### Data profiler

A fully configurable data profiler is available which allows the user to collect information by sampling data at selectable intervals. These time-stamped values can then be viewed to determine weekly load profiles, hourly voltage and/or current fluctuations, battery voltage and current, and frequency. The number of days of information the data profiler can provide depends upon configuration parameters.



Figure 5. Serial RS-232.

### Contact input/output (I/O) module option

The SPEAR control comes pre-configured with two sets of Input and Output contacts. This feature permits connection of contact type input devices (switches, relays) and discrete indicating devices (relays, LEDs, lamps) to the SPEAR control to affect local discrete input/output. The SPEAR control is designed to only have a maximum of 2 Inputs and Output contacts. Additional I/O is not required.

### Communications

The SPEAR control is equipped with one communication accessory expansion bay offering versatile support for modern communication media. One distinct communication option is available, providing two-way, real time SCADA communications with a remote terminal unit (RTU), short or long-range radio, or other communication devices with DNP3 support. The following option is available:

- RS-232 (isolated) Serial communication card

The expansion bay communication accessory concept offers high versatility with respect to communication medium and protocol support. Additional accessories are being continuously developed. Contact your Eaton representative for the latest information regarding particular media and communication protocol support



Figure 6. SPEAR single-phase recloser control-side panel communication port.

**Front panel human-machine interface (HMI)**

The SPEAR control has a newly designed, intuitive Human-Machine Interface (HMI) (Figure 8) that is designed to minimize training costs.



**Figure 7. Display LCD module.**

**Display LCD module (Figure 7)**

- 4 lines-by-16 characters with backlighting option
- Designed with simple to use arrow keypad look and operation
- Automatic backlight shut off after 15 minutes of inactivity

**User interface and LED indicators**

The status indicator LEDs (Figures 9 and 10) provide instant notification on the recloser and control status.

- PHASE FAULT: This LED illuminates when the control issues an overcurrent trip signal while the phase current exceeds the programmed minimum trip value.
- ABOVE MIN TRIP: This LED illuminates when the control detects that current is above the programmed minimum trip value
- LOCKOUT: This LED illuminates to indicate the control is in a locked out state, i.e. a reclosing sequence is not in progress. This LED does not indicate that the recloser is open.
- OPEN: This LED illuminates to indicate the recloser is in the open position
- CLOSED: This LED illuminates to indicate the recloser is in the closed position. The LED will blink when a delayed CLOSE is active. A Close will occur when the manual close delay timer expires.

Common look and feel similar to other ProView NXG Based controls simplifies HMI understanding and operation

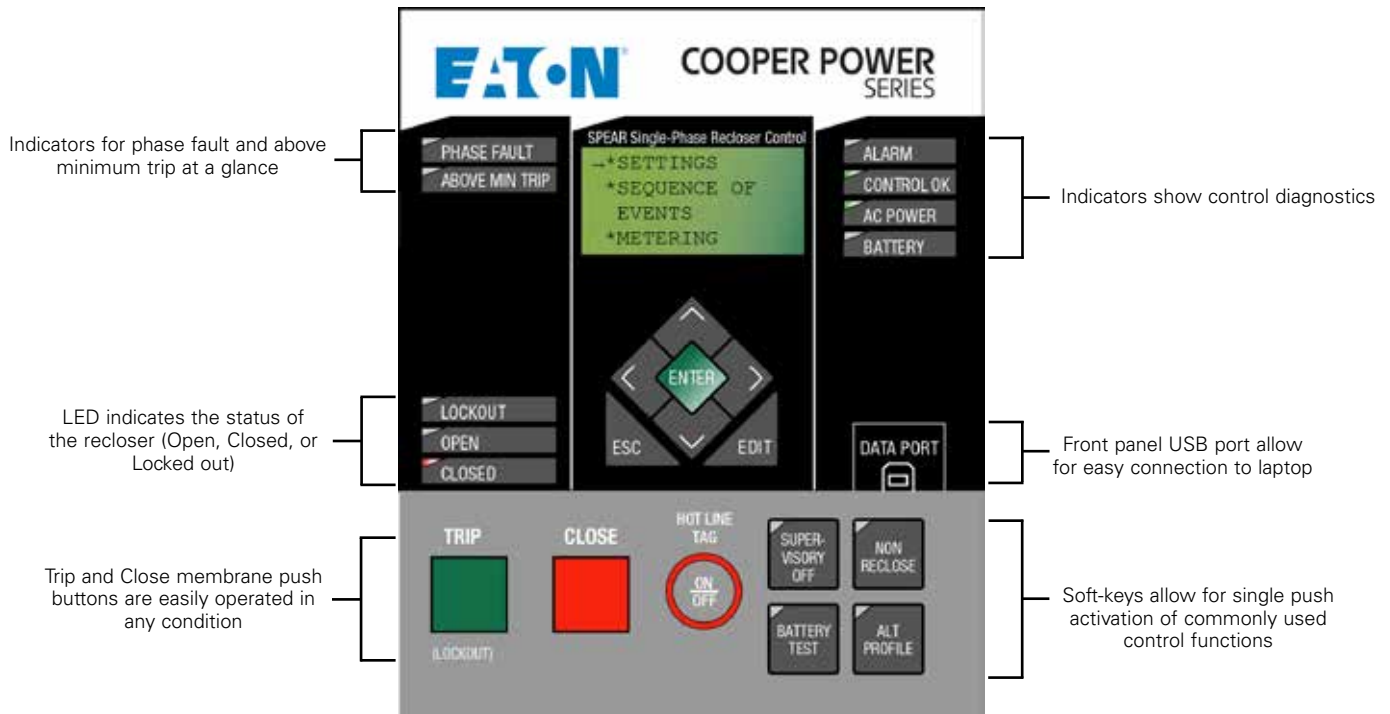

Hot Line Tag membrane push button for easy activation of HLT. A ring of three (3) LEDs indicates when HLT is active.

**Figure 8. Front panel Human-Machine Interface (HMI).**



Figure 9. Status Indicator LEDs.

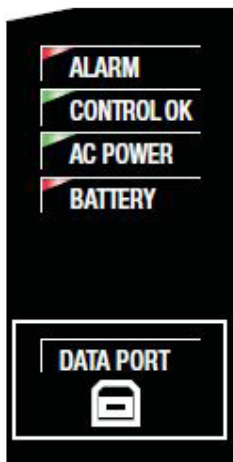

Figure 10. Status Indicator LEDs.



Figure 11. Data Port.

- **ALARM:** This LED illuminates to indicate an alarm condition exists. The LED will flash for unacknowledged alarms, and will continuously illuminate for acknowledged alarms.
- **CONTROL OK:** This indicator illuminates to indicate that the control passed self-diagnostics and is capable of normal operation
- **AC POWER:** This indicator is illuminated when the presence of ac input power to the control is sensed
- **BATTERY:** This LED illuminates to indicate battery voltage is low or the battery failed an operator-initiated manual test

The DATA PORT section (Figure 11) on the front operating panel allows for direct connection to a personal computer.

- The USB data port is a client port used to communicate with the control from a personal computer. This port is used for accessing the control with ProView NXG application software. All settings, metering, alarms, and events are available from this port.

### Operating panel (Figure 12)

- **TRIP (Lockout) Membrane Push Button:** The TRIP push button provides front-panel access to trip (lockout) the recloser. When pressed, the TRIP push button opens the recloser and locks out the control.
- **CLOSE Membrane Push Button:** When pressed, the CLOSE push button returns the control to the initial or home sequence position, closing the recloser. The control is ready for the start of a new trip/close sequence.
- **HOT LINE TAG ON/OFF:** Hot Line Tag is provided for live-line work applications. All closing operations are disabled when the Hot Line Tag feature is activated.

Hot Line Tag prevents all closing attempts from the control and shifts protection to one trip-to-lockout on the composite curve of the Hot Line Tag definite time and the TCC1 curve (whichever is faster). Hot Line Tag takes precedence over Cold Load Pickup, Non-Reclosing, and Fast Trips Disabled.

Hot Line Tag is activated from either the operator panel membrane push button, local, or remote communications. All sources must be off to de-activate Hot Line Tag.

The Hot Line Tag function may only be reset by the source which initiates it.



Figure 12. Operating Panel.



**One-touch function keys (Figure 13)****SUPERVISORY OFF**

When the SUPERVISORY OFF red indicator is illuminated, supervisory commands are blocked. Supervisory functions through the USB data port is not blocked. Communications through the front panel USB port remain active independent of the status of the SUPERVISORY OFF switch. Activation of this function key is restricted to the operator panel. Operational data and metering information are available while the control is in the SUPERVISORY OFF position.

**NON RECLOSE**

The control is operating in a non-reclosing mode when the NON RECLOSE indicator is illuminated. Non-reclosing mode disables any automatic reclosing operations. Non-reclosing does not alter the active TCC. Activation is possible from the SCADA port, the interface software, or locally (via the front panel).

**BATTERY TEST**

A direct shortcut to run the battery test feature. The LCD screen will show the battery voltage and current. After the battery test is run, the battery test results are shown (battery voltage and current).

**ALT PROFILE**

The SPEAR control has two protection profiles; a normal profile, and Alternate Profile. When the operator panel display lights are active and the ALT PROFILE indicator is not illuminated, the Normal profile is active. Only one profile can be active.

To select the alternate profile, press the ALT PROFILE button.

To return to the Normal profile, press the ALT PROFILE button to deselect it. These functions can also be completed remotely via communications interfaces.



**Figure 13. One-touch function keys.**

**Operation upon loss of ac power**

The control is equipped with an 8 Amp-Hour 24 Vdc lead acid battery for operation upon loss of ac power. The control maintains full operation from the battery for a period of time dependent upon the battery size:

- 8 Amp-Hour – 48 hour (approximate) maximum (20 °C)

Control programming settings and parameters – including event recorder – are stored in non-volatile memory and retained upon loss of control power. The time/date clock will continue to operate for approximately 30 days after loss of control power.

**Accessories****Incoming power receptacles**

The Incoming Power Receptacle allows the user to conveniently plug the power cable into the control, eliminating the need for hardwiring to the control. Table 8 includes the part number for the ac input cable of varying lengths.

**Cable locking sleeves**

To prevent detachment of the control cable from the control cabinet by unauthorized personnel, a cable-locking sleeve is available to enclose the cable plug. The plug is passed through the sleeve and the sleeve is then fastened from inside the control cabinet. There is no access to the cable receptacle without opening the locked cabinet door and detaching the sleeve. The cable locking sleeves can be ordered up to a quantity of three (3). Refer to Table 11 for the correct catalog number based on quantity.

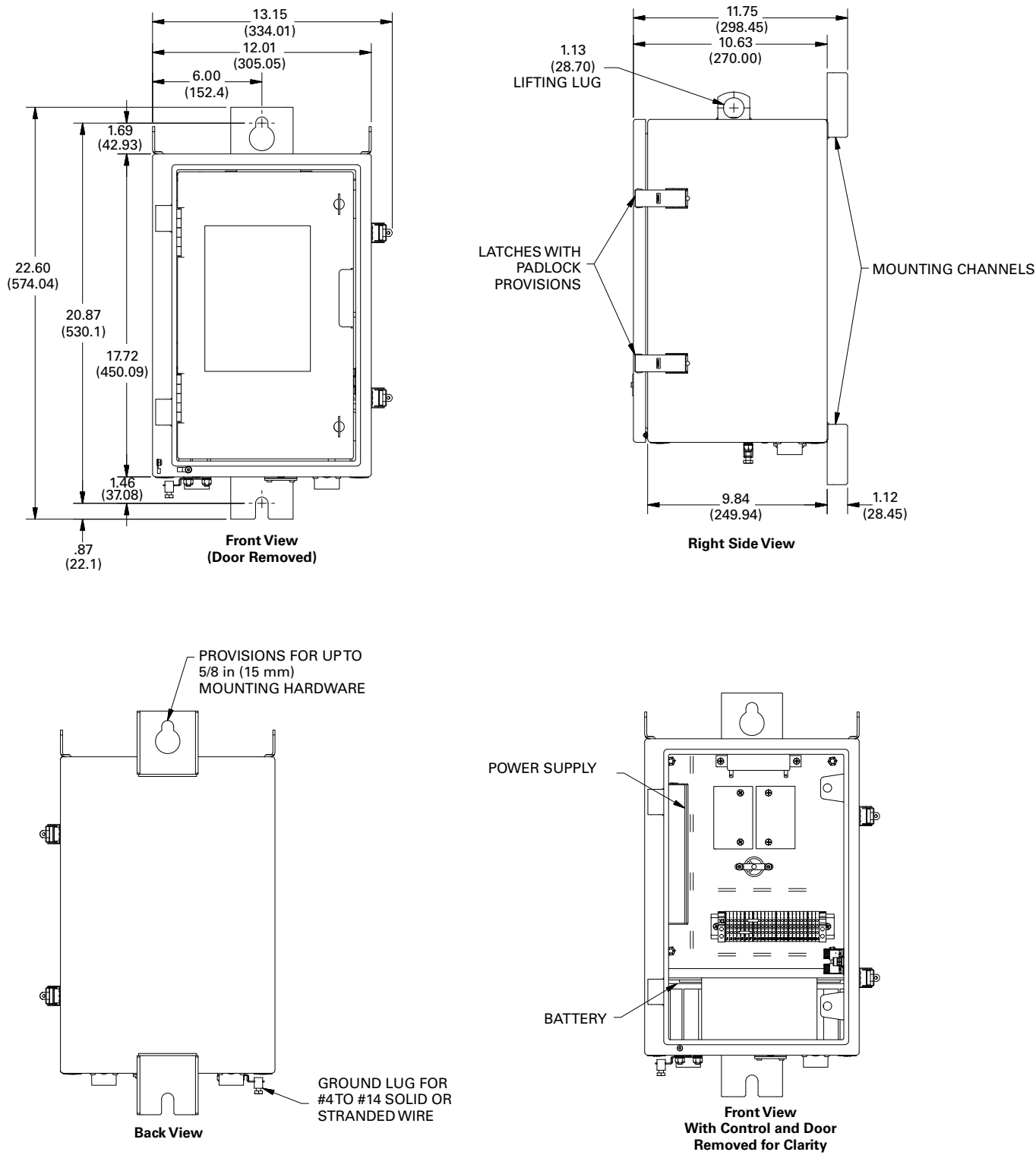

Figure 14. SPEAR control dimensions.

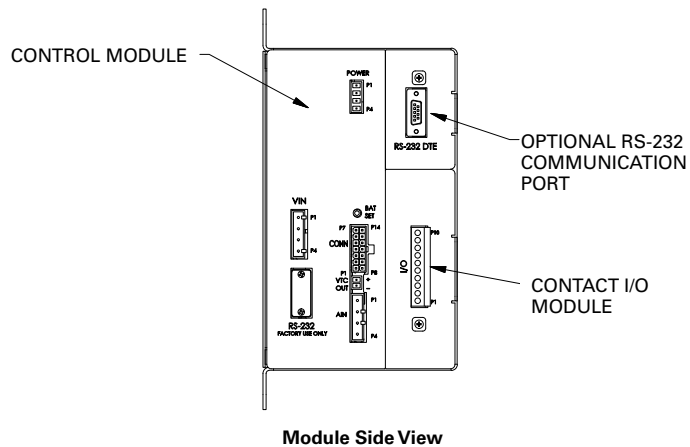
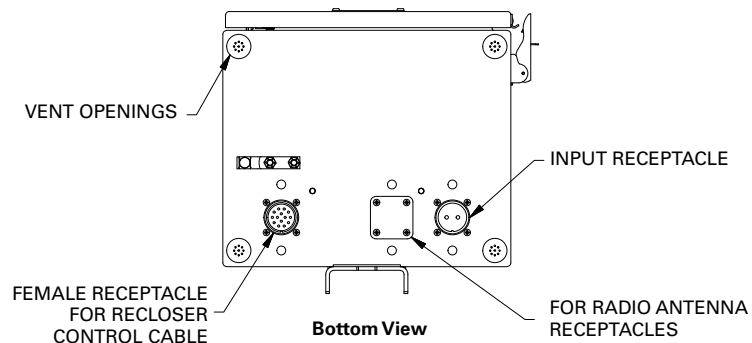

Figure 14. SPEAR control dimensions (continued).

**Eaton**  
1000 Eaton Boulevard  
Cleveland, OH 44122  
United States  
Eaton.com

**Eaton's Power Systems Division**  
2300 Badger Drive  
Waukesha, WI 53188  
United States  
Eaton.com/cooperpowerseries

© 2016 Eaton  
All Rights Reserved  
Printed in USA  
Publication No. CA280001EN

Eaton is a registered trademark.  
All other trademarks are property  
of their respective owners.

For Eaton's Cooper Power series SPEAR  
recloser system product information  
call 1-877-277-4636 or visit:  
[www.eaton.com/cooperpowerseries](http://www.eaton.com/cooperpowerseries).